

# HANDS-ON SDN

*Introduction to Software-defined Networking*  
Block Course – 16-20 March 2015

David Koll

# FlowVisor

- FlowVisor: Implemented in JAVA
- Sources at: <https://github.com/opennetworkinglab/flowvisor/>
- Recall: FlowVisor is an extra layer between controllers and switches

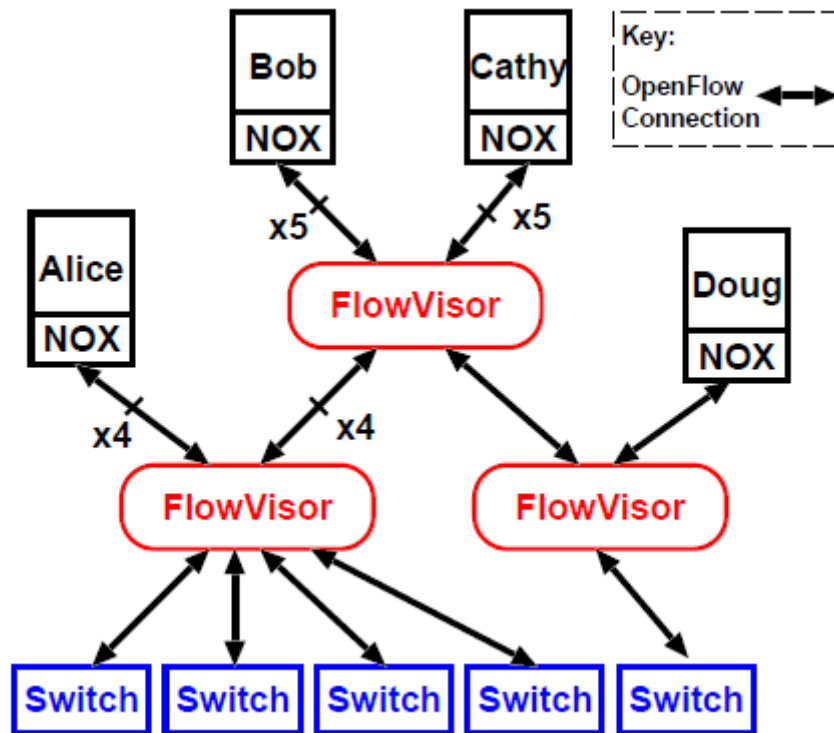

Taken from: Sherwood, et al. "Flowvisor: A network virtualization layer." OpenFlow Switch Consortium, Tech. Rep (2009).

# FlowVisor

- Basic procedure:
  - Create and start your network topology with Mininet
  - Connect Flowvisor to switches on standard port
  - Slice network with Flowvisor
  - Connect Controllers to Flowvisor slices



# FlowVisor

- Basic procedure:
  - Create and start your network topology with Mininet
  - Connect Flowvisor to switches on standard port
  - Slice network with Flowvisor
  - Connect Controllers to Flowvisor slices



# Connecting FlowVisor

- FlowVisor operates outside of Mininet!

```
$ sudo /etc/init.d/flowvisor start
```

**(see demo)**

- Afterwards: use flowvisor control (command: `fvctl`) to slice



# Slicing the Network with FlowVisor

- First: enable topology controller

```
$ fvctl -f /dev/null set-config --enable-topo-ctrl  
$ sudo /etc/init.d/flowvisor restart
```

**(see demo)**

- -f /dev/null option: -f points to pwd file – in our case: empty pw

# Let's slice the research lab

Each: 100gbps, 1ms delay

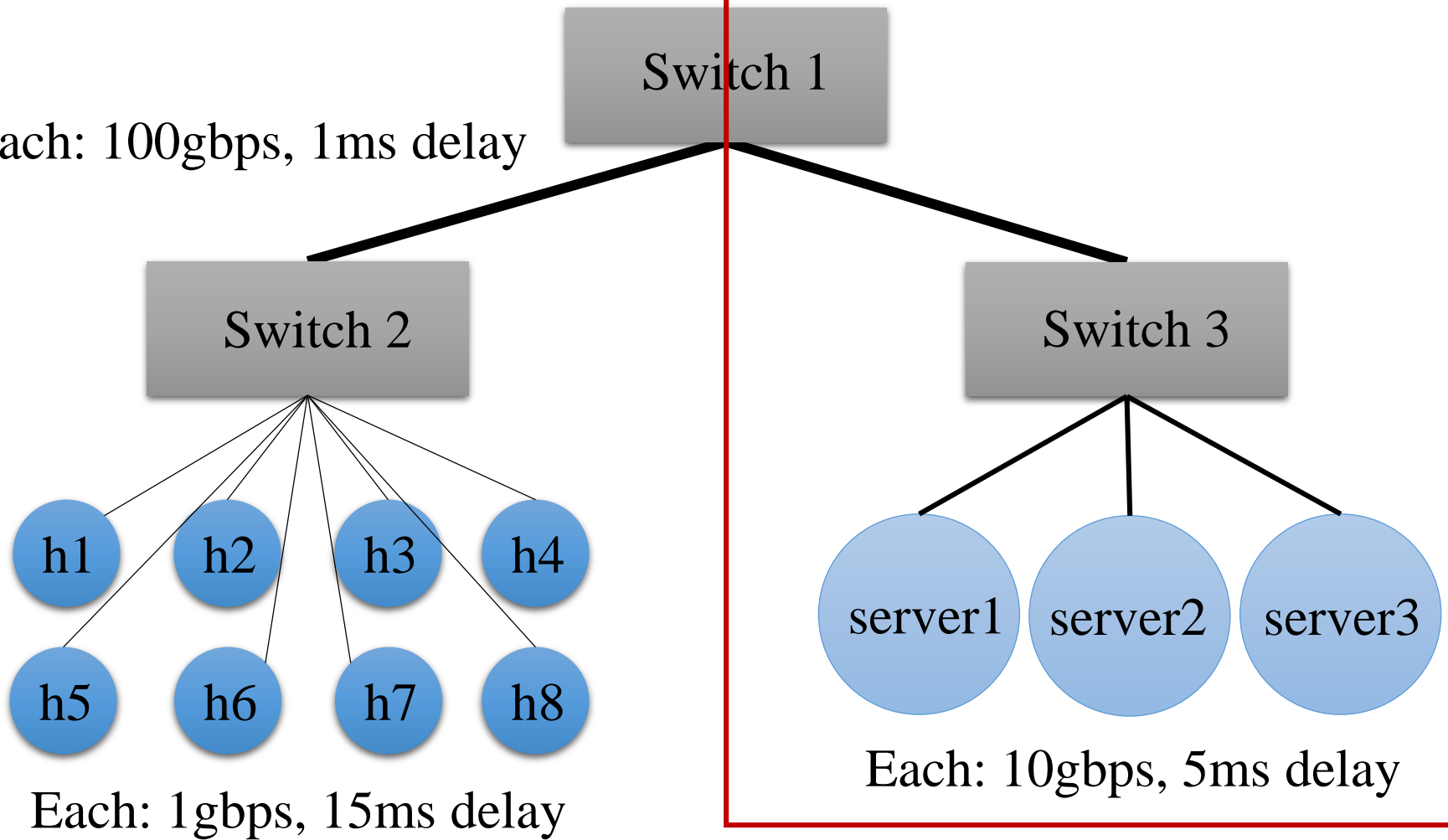

Each: 1gbps, 15ms delay



# Slicing the Network with FlowVisor

- Want to create slice for servers. Have a look at topology:

```
$ fvctl -f /dev/null list-slices
```

```
$ fvctl -f /dev/null remove-slice <slice>
```

```
$ fvctl -f /dev/null list-flowspace
```

```
$ fvctl -f /dev/null list-datapaths
```

```
$ fvctl -f /dev/null list-links
```

**(see demo)**





# Slicing the Network with FlowVisor

- Add slices with

```
fvctl add-slice [options] <slicename>  
                <controller-url> <admin-email>
```

```
$ fvctl -f /dev/null add-slice servers  
                tcp:localhost:10001 admin@servers
```

**(see demo)**



# Add Flowspaces

- Add flowspaces with

```
fvctl add-flowspace [options] <flowspace-name> <dpid>  
                    <priority> <match> <slice-perm>
```

```
$ fvctl -f /dev/null add-flowspace switch1-port2  
    1 1 in_port=2 servers=7
```

- Permissions: Bitmask
  - 1=DELEGATE, 2=READ, 4=WRITE

**(see demo)**



# Connect Controllers

- Start controller and connect to FlowVisor

**(see demo)**



# Test Slicing

- Servers should be able to ping each other, but not any hosts

**(see demo)**

# Recap: Hands-On SDN

Reasons for using network emulation

First steps in Mininet

Mininet topologies

Mininet, controllers and OpenFlow

Network Virtualization with FlowVisor

# Exercise!

Time for Exercise 8