

# Network Layer – Part III

## *Multicast and Mobility*

Computer Networks, Winter 2014/2015



# Network Layer III

- 4.6 Multicast
  - Broadcast routing
  - Multicast routing
  - Multicast routing protocols
- 4.7 Mobility
  - What is Mobility?
  - Network layer mobility concepts and principles
  - Mobile IP

# Broadcast Routing

- Deliver packets from source to all other nodes
- Source duplication is inefficient:

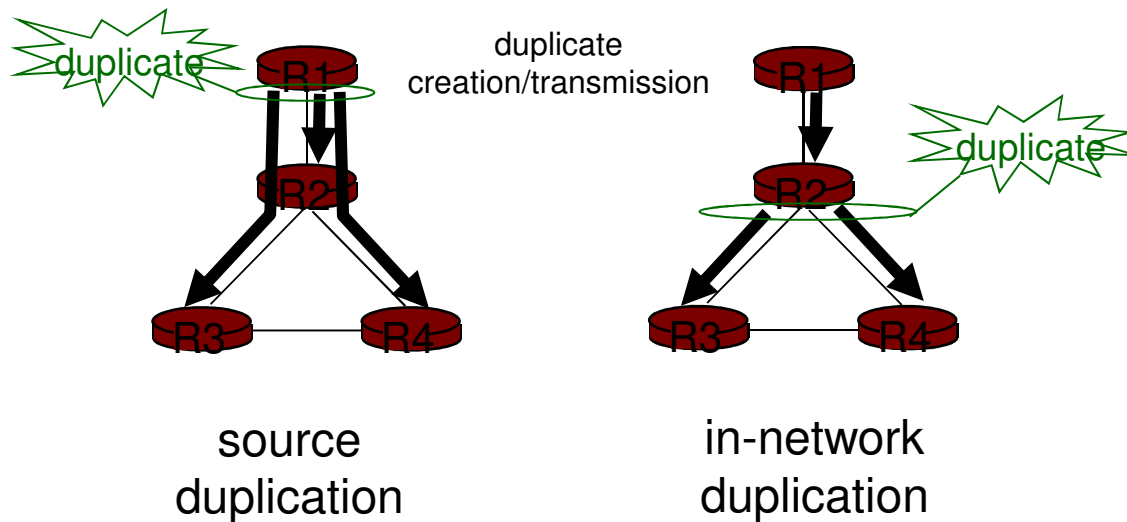

- Source duplication: how does source determine recipient addresses?

# In-network duplication

- **Flooding:** when node receives broadcast packets, sends copy to all neighbors
  - Problems: cycles & broadcast storm
- **Controlled flooding:** node only broadcast pkt if it hasn't broadcasted same pkt before
  - Node keeps track of pkt ids already broadcasted
  - Reverse path forwarding (RPF): only forward pkt if it arrived on shortest path between node and source
- **Spanning tree**
  - No redundant packets received by any node

# Spanning Tree

- First construct a spanning tree
- Nodes forward copies only along spanning tree

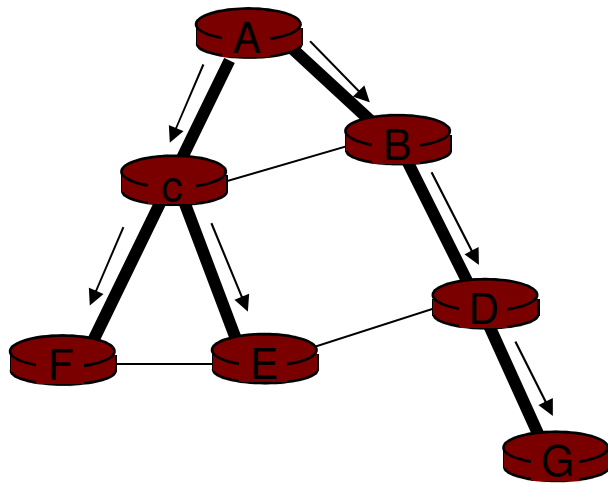

(a) Broadcast initiated at A

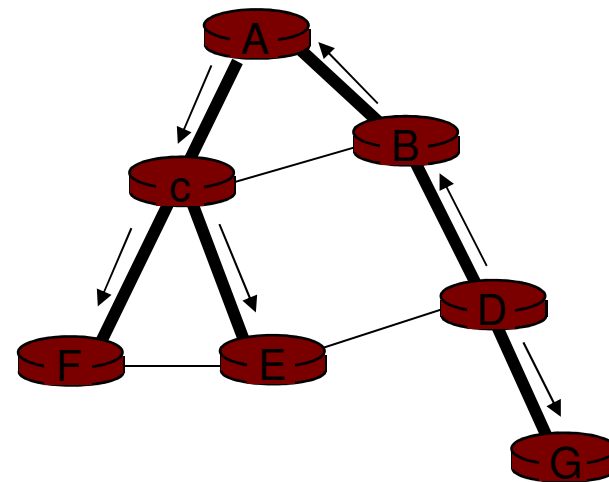

(b) Broadcast initiated at D

# Spanning Tree: Creation

- Center node
- Each node sends unicast join message to center node 'E'
  - Message forwarded until it arrives at a node already belonging to spanning tree

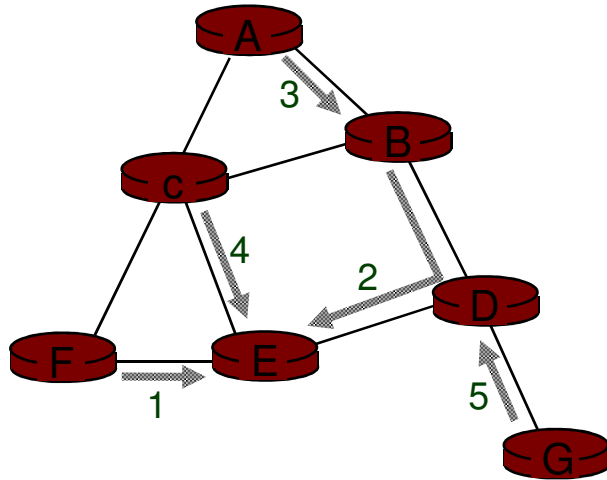

(a) Stepwise construction of spanning tree

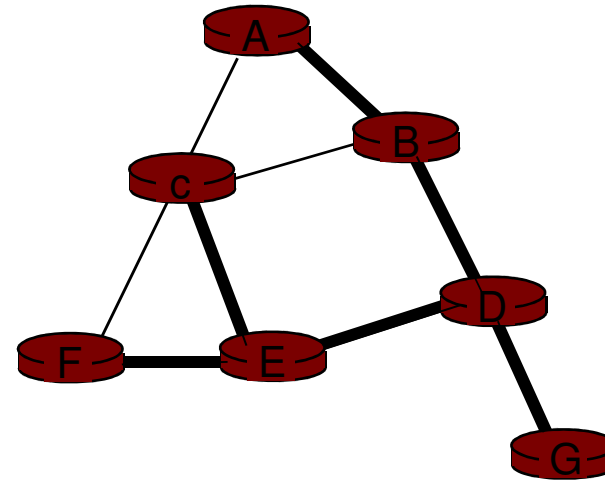

(b) Constructed spanning tree

# Network Layer II

- 4.6 Multicast
  - Broadcast routing
  - Multicast routing
  - Multicast routing protocols
- 4.7 Mobility
  - What is Mobility?
  - Network layer mobility concepts and principles
  - Mobile IP

# Multicast Routing: Problem Statement

- **Goal:** find a tree (or trees) connecting routers that have local multicast group members
  - Tree: not all paths between routers used
  - Source-based: different tree from each sender to receiver
  - Shared-tree: same tree used by all group members

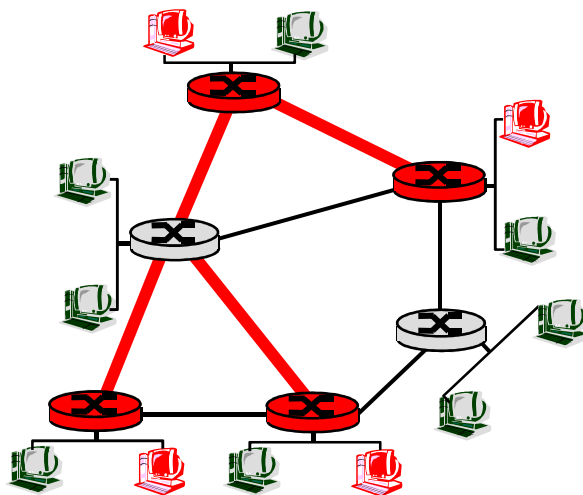

Shared tree

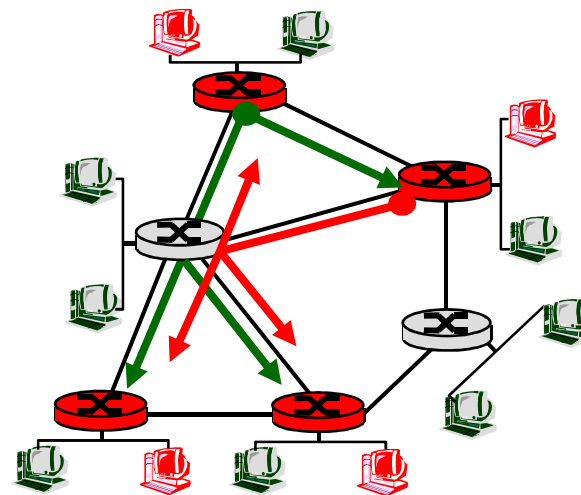

Source-based trees



# Approaches for building mcast trees

- Source-based tree: one tree per source
  - shortest path trees
  - reverse path forwarding
- Group-shared tree: group uses one tree
  - minimal spanning (Steiner)
  - center-based trees

# Shortest Path Tree

- Multicast forwarding tree: tree of shortest path routes from source to all receivers
  - Dijkstra's algorithm

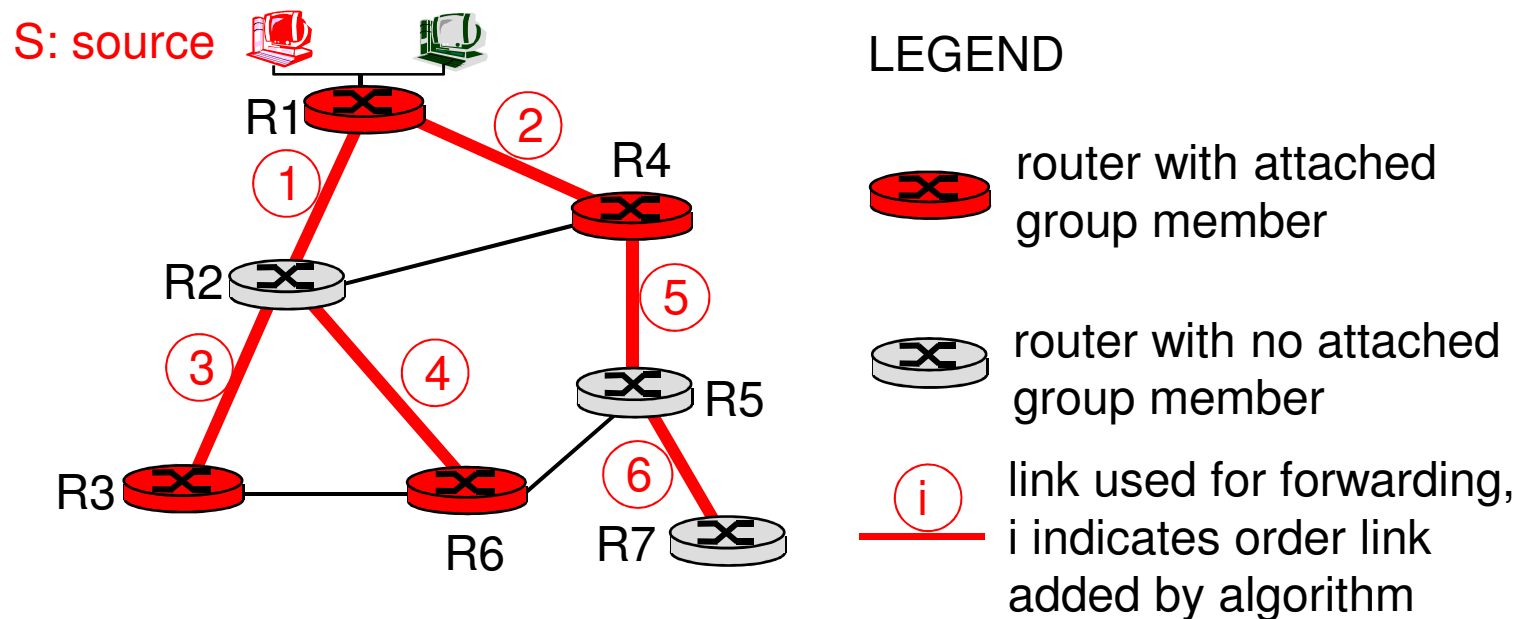

# Reverse Path Forwarding

- Relies on router's knowledge of unicast shortest path from it to sender
- Each router has simple forwarding behavior:
  - if (multicast datagram received on incoming link on shortest path back to center)
  - then flood datagram onto all outgoing links
  - else ignore datagram

# Reverse Path Forwarding: example

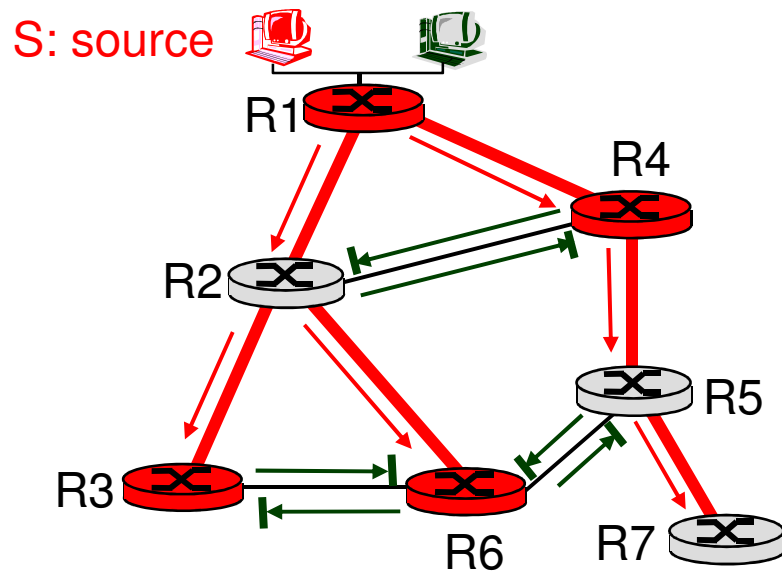

## LEGEND

- router with attached group member
- router with no attached group member
- datagram will be forwarded
- datagram will not be forwarded



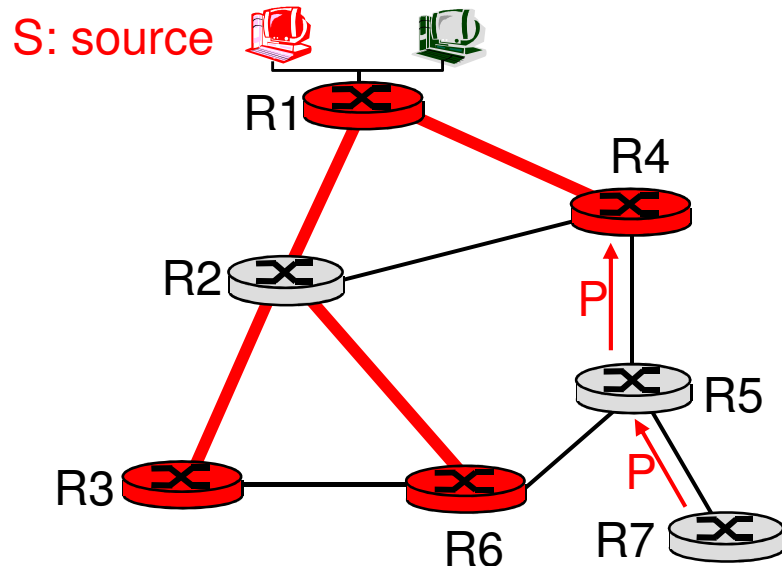

- result is a source-specific *reverse* SPT
  - may be a bad choice with asymmetric links

# Reverse Path Forwarding: pruning

- forwarding tree contains subtrees with no multicast group members
  - no need to forward datagrams down subtree
  - “prune” msgs sent upstream by router with no downstream group members



## LEGEND

-  router with attached group member
-  router with no attached group member
-  prune message
-  links with multicast forwarding

# Center-based trees



- Single delivery tree shared by all
- One router identified as “center” of tree
- To join:
  - edge router sends unicast join-msg addressed to center router
  - join-msg “processed” by intermediate routers and forwarded towards center
  - join-msg either hits existing tree branch for this center, or arrives at center
  - path taken by join-msg becomes new branch of tree for this router

# Center-based trees: an example

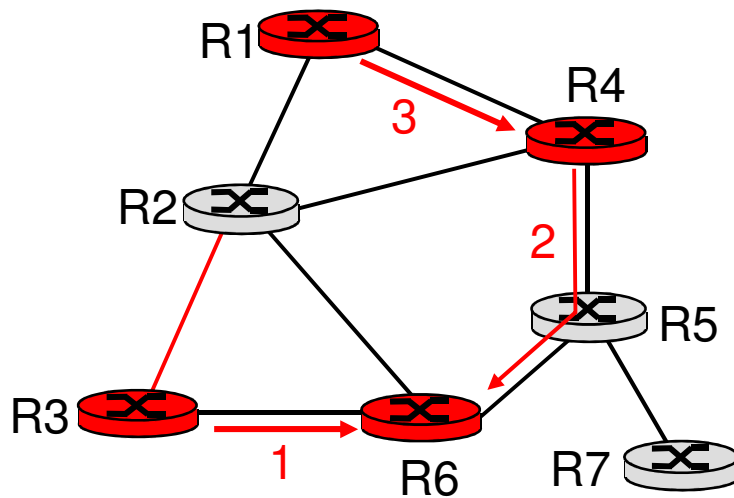
Suppose R6 chosen as center:



## LEGEND

-  router with attached group member
-  router with no attached group member
-  path order in which join messages generated

# Network Layer II

- 4.6 Multicast
  - Broadcast routing
  - Multicast routing
  - Multicast routing protocols
- 4.7 Mobility
  - What is Mobility?
  - Network layer mobility concepts and principles
  - Mobile IP



# Internet Multicast Service Model

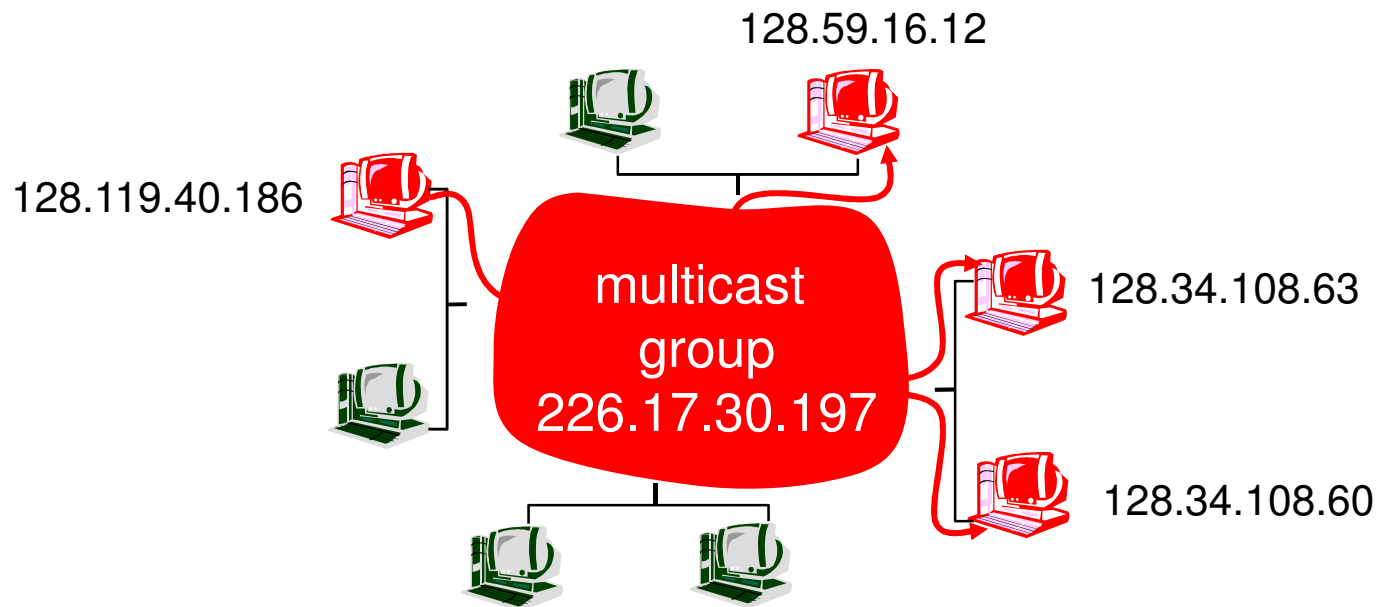

Multicast group concept: use of **indirection**

- hosts addresses IP datagram to multicast group
- routers forward multicast datagrams to hosts that have “joined” that multicast group

# Multicast Groups

- Class D Internet addresses reserved for multicast:

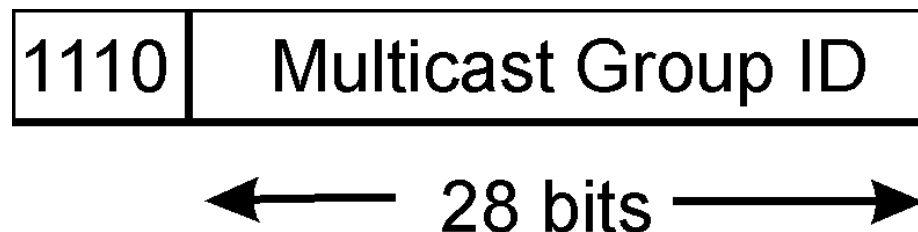

- Host group semantics:
  - anyone can “join” (receive pkts) multicast group
  - anyone can send pkts to multicast group
  - no network-layer identification to hosts of the members
- Needed: infrastructure to deliver mcast-addressed datagrams to all hosts that have joined that multicast group

# Joining a mcast group: two-step process

- **Local:** host informs local mcast router of a desire to join group:
  - IGMP (Internet Group Management Protocol)
- **Wide area:** local router interacts with other routers to receive mcast datagram flow
  - many protocols (e.g., DVMRP, MOSPF, PIM)

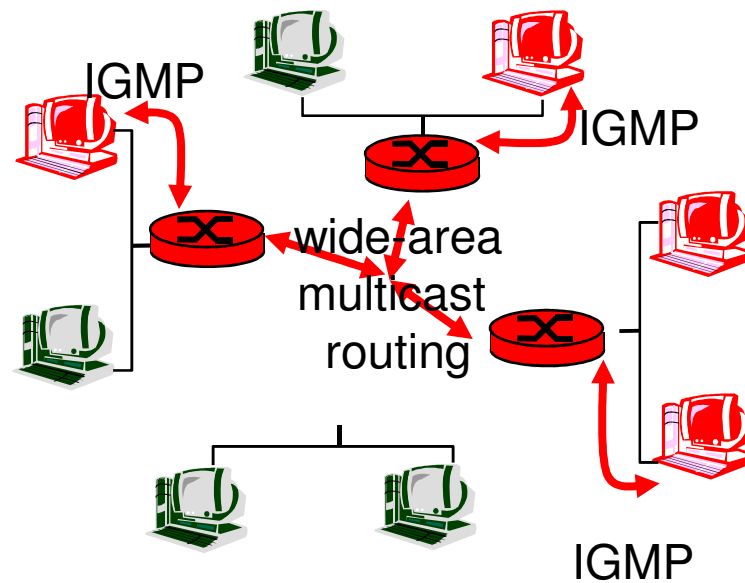

# IGMP: Internet Group Management Protocol

- **Host:** sends IGMP report when application joins mcast group
  - IP\_ADD\_MEMBERSHIP socket option
  - host needs not explicitly “disjoin” group when leaving
- **Router:** sends IGMP query at regular intervals
  - host belonging to a mcast group must reply to query

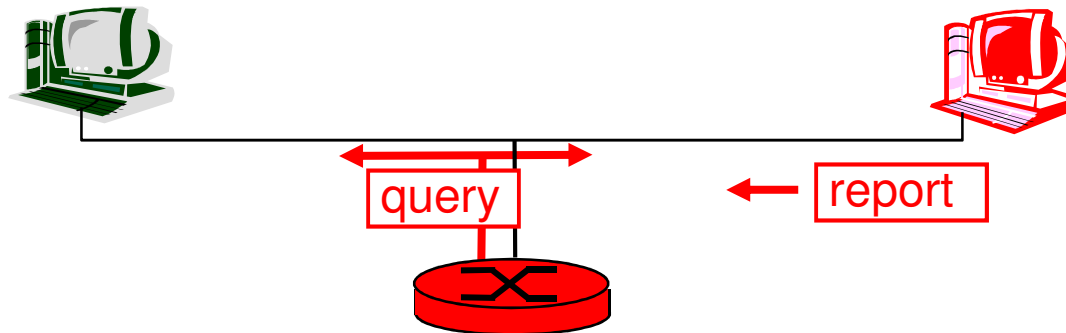

# Internet Multicasting Routing: DVMRP

- DVMRP: distance vector multicast routing protocol, RFC1075
- flood and prune: reverse path forwarding, source-based tree
  - RPF tree based on DVMRP's own routing tables constructed by communicating DVMRP routers
  - no assumptions about underlying unicast
  - initial datagram to mcast group flooded everywhere via RPF
  - routers not wanting group: send upstream prune msgs

# DVMRP: continued...

- soft state: DVMRP router periodically (1 min.) “forgets” branches are pruned:
  - mcast data again flows down unpruned branch
  - downstream router: re prune or else continue to receive data
- routers can quickly regraft to tree
  - following IGMP join at leaf
- odds and ends
  - commonly implemented in commercial routers
  - Mbone routing done using DVMRP

# Tunneling

- Q: How to connect “islands” of multicast routers in a “sea” of unicast routers?

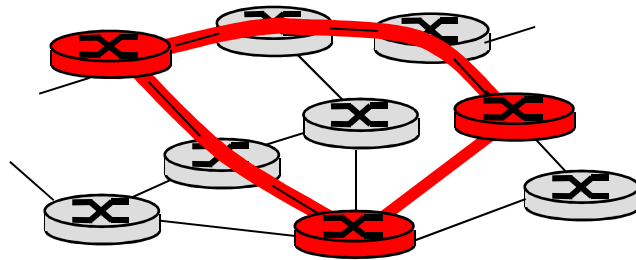

physical topology

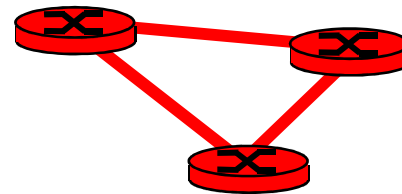

logical topology

- mcast datagram encapsulated inside “normal” (non-multicast-addressed) datagram
- normal IP datagram sent through “tunnel” via regular IP unicast to receiving mcast router
- receiving mcast router de-capsulates pkt to get mcast datagram

# PIM: Protocol Independent Multicast

- not dependent on any specific underlying unicast routing algorithm (works with all)
- two different multicast distribution scenarios :
  - Dense:
    - group members densely packed, in “close” proximity.
    - bandwidth more plentiful
  - Sparse:
    - # networks with group members small wrt # interconnected networks
    - group members “widely dispersed”
    - bandwidth not plentiful



# Consequences of Sparse-Dense Dichotomy

- Dense
  - group membership by routers assumed until routers explicitly prune
  - data-driven construction on mcast tree (e.g., RPF)
  - bandwidth and non-group-router processing profligate
- Sparse
  - no membership until routers explicitly join
  - receiver- driven construction of mcast tree (e.g., center-based)
  - bandwidth and non-group-router processing conservative

# PIM- Dense Mode

- Flood-and-prune RPF, similar to DVMRP but
  - underlying unicast protocol provides RPF info for incoming datagram
  - less complicated (less efficient) downstream flood than DVMRP reduces reliance on underlying routing algorithm
  - has protocol mechanism for router to detect it is a leaf-node router

# PIM - Sparse Mode

- center-based approach
- router sends *join* msg to rendezvous point (RP)
  - intermediate routers update state and forward *join*
- after joining via RP, router can switch to source-specific tree
  - increased performance: less concentration, shorter paths

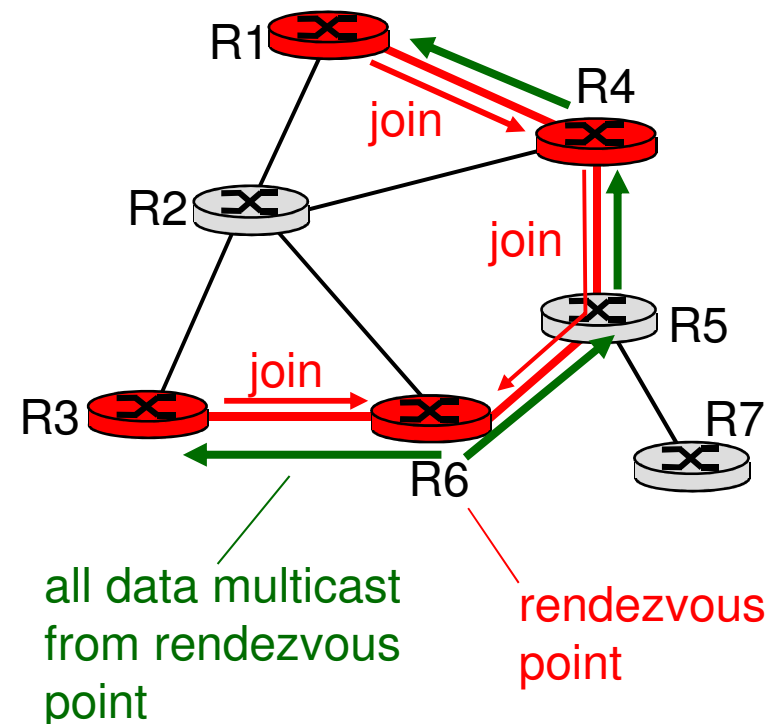

# PIM - Sparse Mode

## sender(s):

- unicast data to RP, which distributes down RP-rooted tree
- RP can extend mcast tree upstream to source
- RP can send *stop* msg if no attached receivers
  - “no one is listening!”

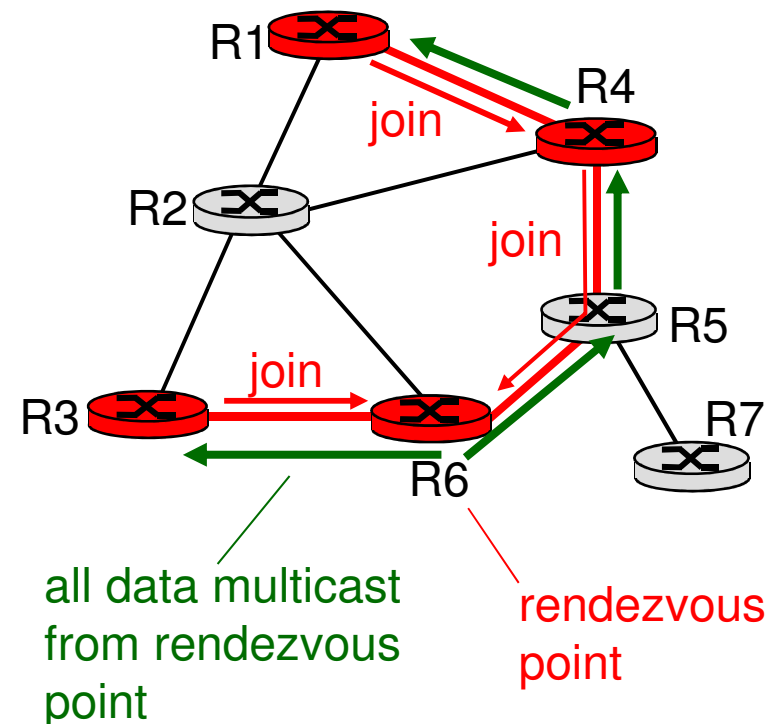

# Network Layer II

- 4.6 Multicast
  - Broadcast routing
  - Multicast routing
  - Multicast routing protocols
- 4.7 Mobility
  - What is Mobility?
  - Network layer mobility concepts and principles
  - Mobile IP

# What is mobility?

- spectrum of mobility, from the *network* perspective:

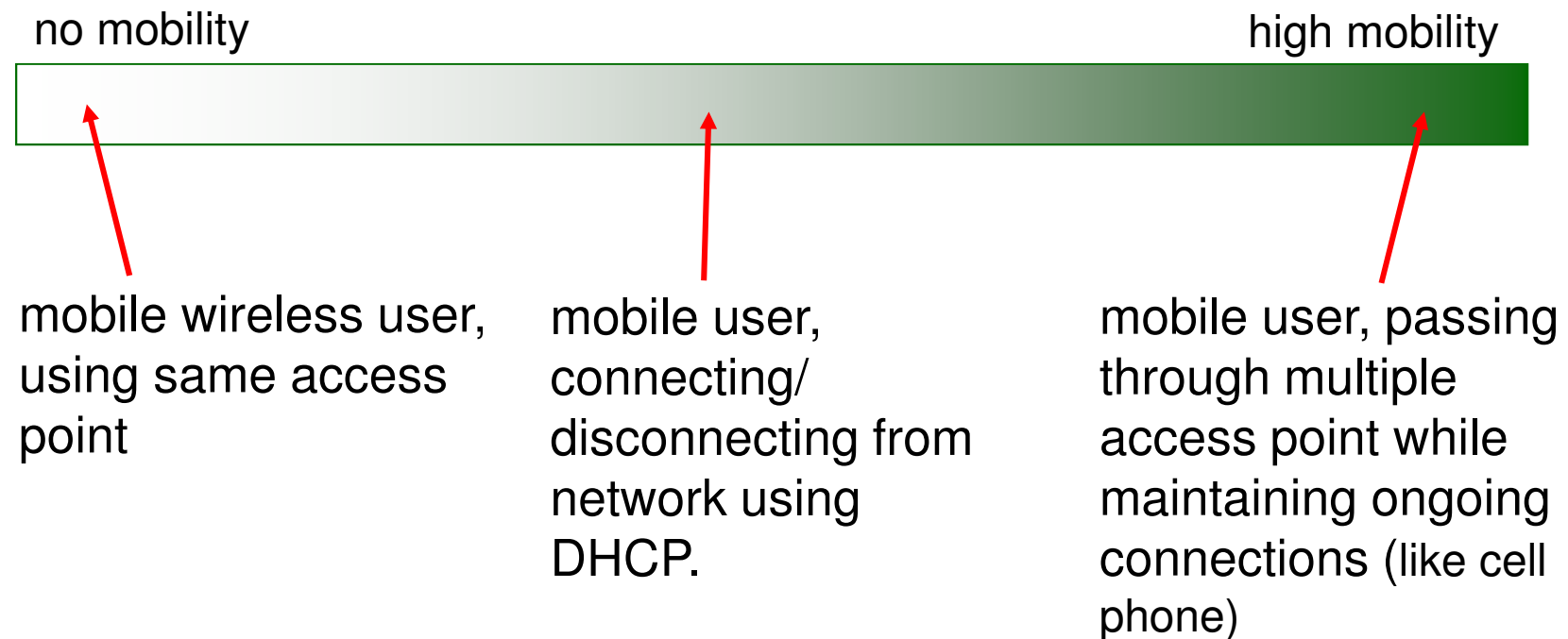

# Mobility: Vocabulary

**home network:** permanent  
“home” of mobile  
(e.g., 128.119.40/24)

**home agent:** entity that will  
perform mobility functions on  
behalf of mobile, when mobile is  
remote

**Permanent address:**  
address in home  
network, *can always* be  
used to reach mobile  
e.g., 128.119.40.186

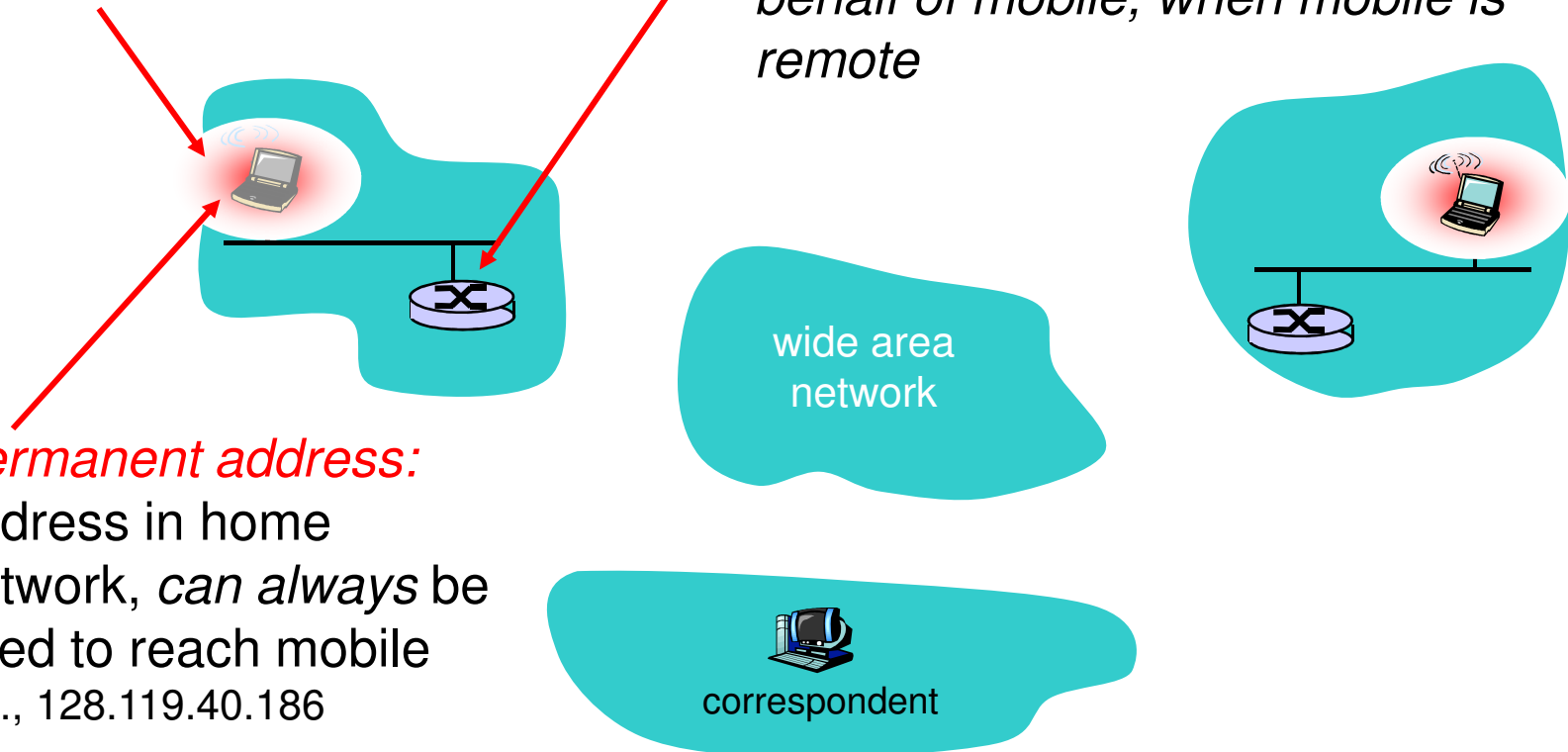

# Mobility: more vocabulary

*Permanent address:* remains constant (e.g., 128.119.40.186)

*visited network:* network in which mobile currently resides (e.g., 79.129.13/24)

*Care-of-address:* address in visited network. (e.g., 79.129.13.2)

wide area network

*foreign agent:* entity in visited network that performs mobility functions on behalf of mobile.

*correspondent:* wants to communicate with

*mobile*





# How do *you* contact a mobile friend:

Consider friend frequently changing addresses, how do you find her?

- search all phone books?
- call her parents?
- expect her to let you know where he/she is?

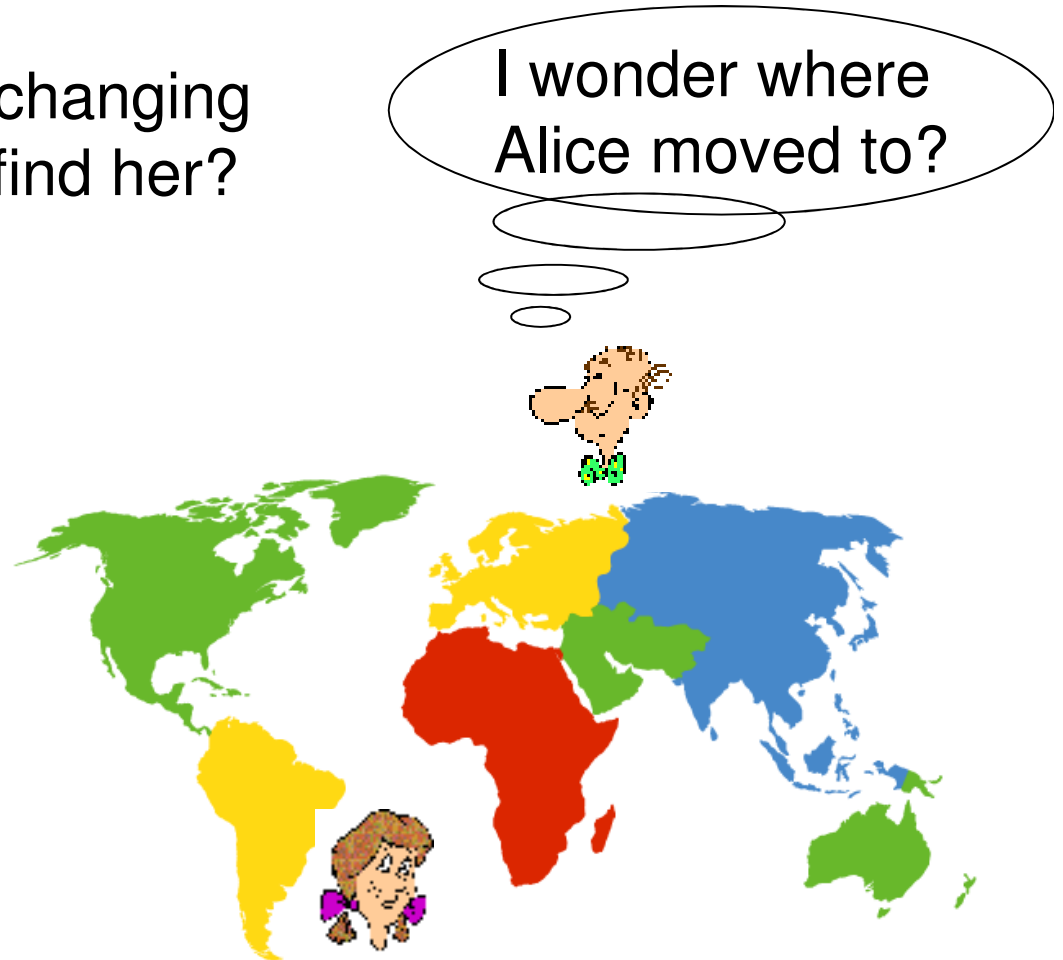

# Network Layer II

- 4.6 Multicast
  - Broadcast routing
  - Multicast routing
  - Multicast routing protocols
- 4.7 Mobility
  - What is Mobility?
  - Network layer mobility concepts and principles
  - Mobile IP

# Mobility: approaches

- Let routing handle it
  - routers advertise permanent address of mobile-nodes via usual routing table exchange.
  - routing tables indicate where each mobile located
  - no changes to end-systems
  - **does not scale well!**

# Mobility: approaches

- Let end-systems handle it
  - **Indirect routing:** communication from correspondent to mobile goes through home agent, then forwarded to remote
  - **Direct routing:** correspondent gets foreign address of mobile, sends directly to mobile

# Mobility: registration

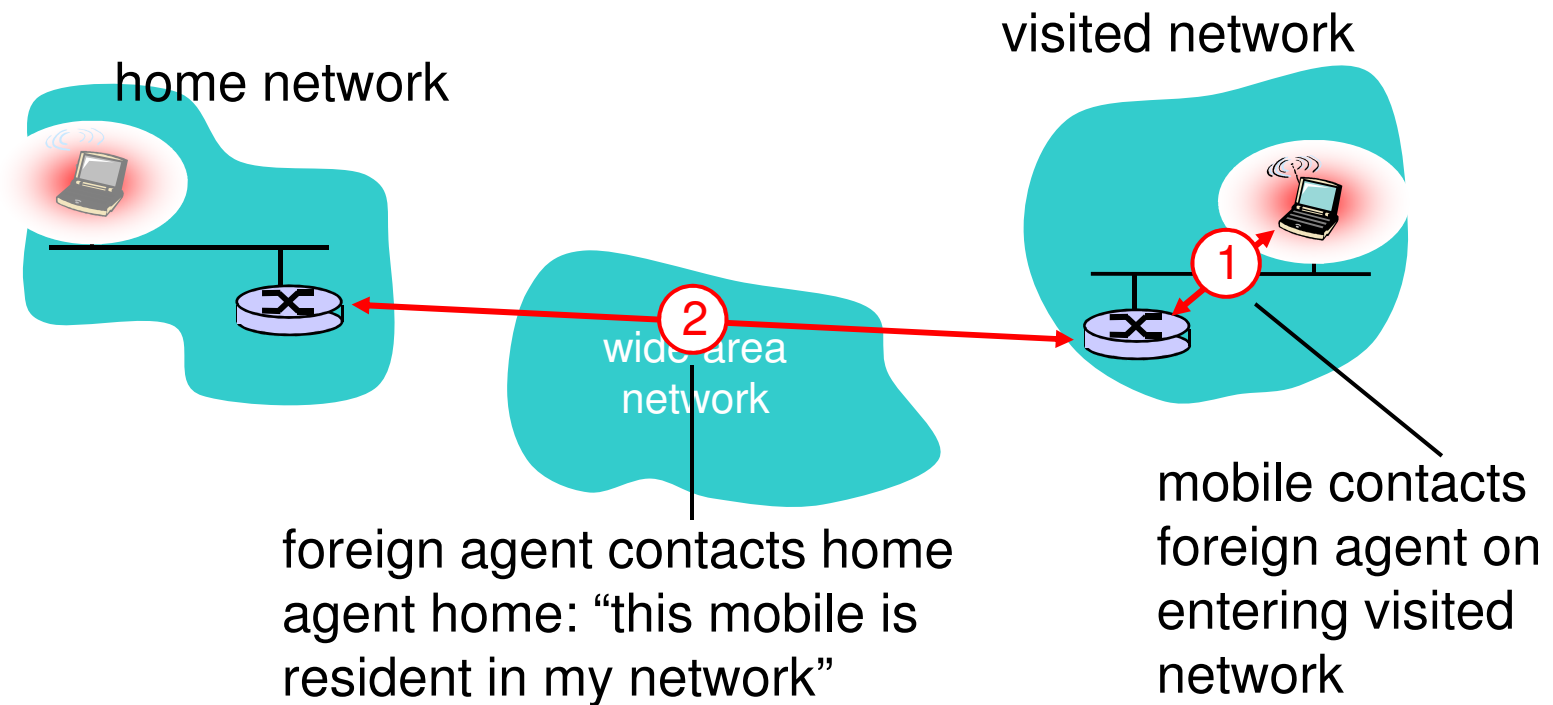

End result:

- Foreign agent knows about mobile
- Home agent knows location of mobile

# Mobility via Indirect Routing

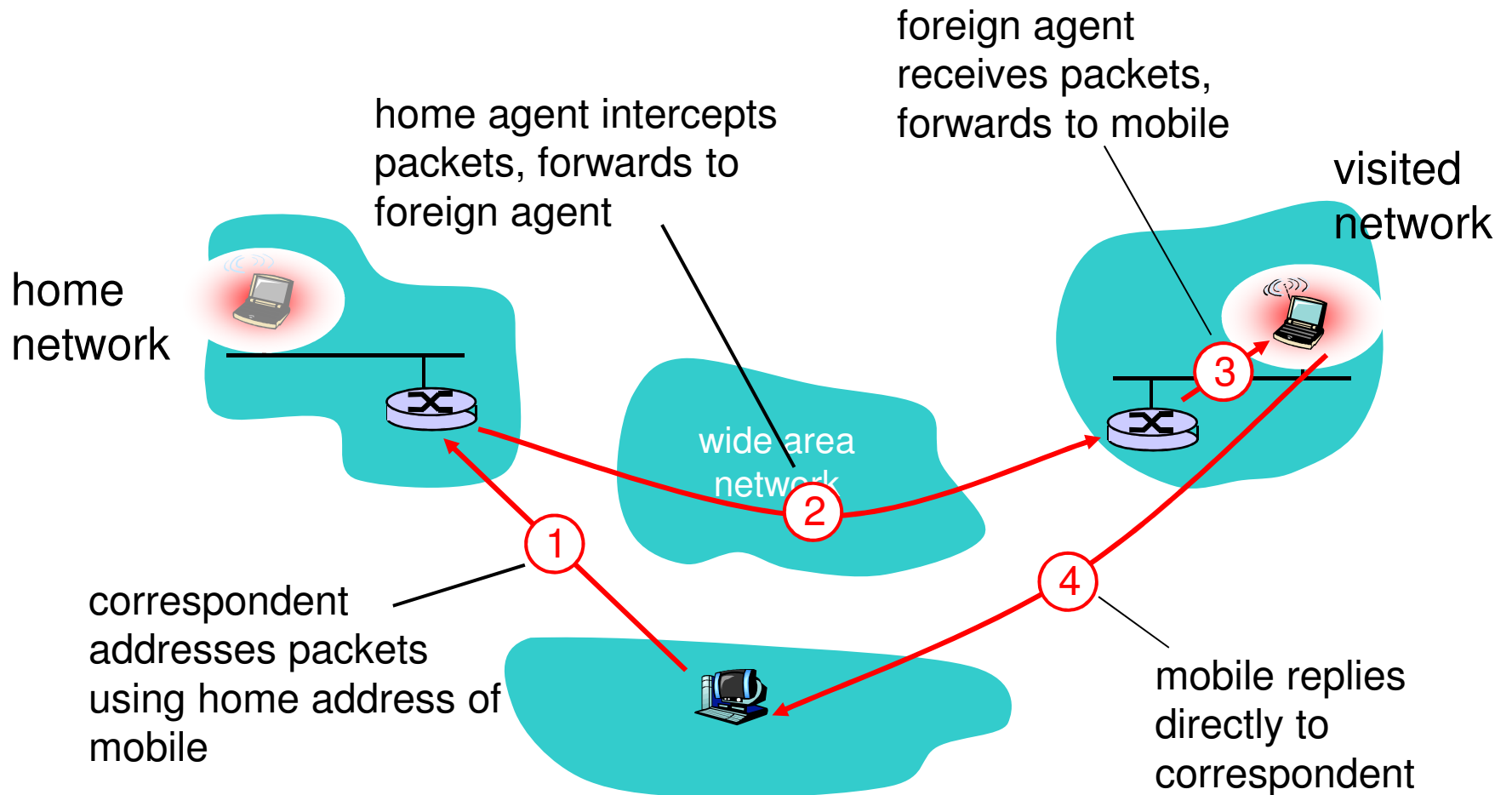

# Indirect Routing: comments

- Mobile uses two addresses:
  - **permanent address**: used by correspondent (hence mobile location is *transparent* to correspondent)
  - **care-of-address**: used by home agent to forward datagrams to mobile
- foreign agent functions may be done by mobile itself
- **triangle routing**: correspondent-home-network-mobile
  - inefficient when correspondent, mobile are in same network

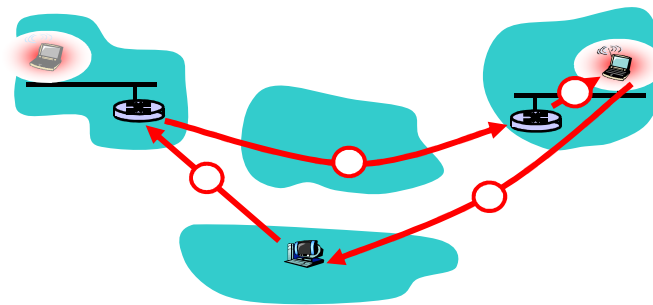

# Indirect Routing: moving between networks

- suppose mobile user moves to another network
  - registers with new foreign agent
  - new foreign agent registers with home agent
  - home agent update care-of-address for mobile
  - packets continue to be forwarded to mobile (but with new care-of-address)
- mobility, changing foreign networks transparent: *ongoing connections can be maintained!*



# Mobility via Direct Routing

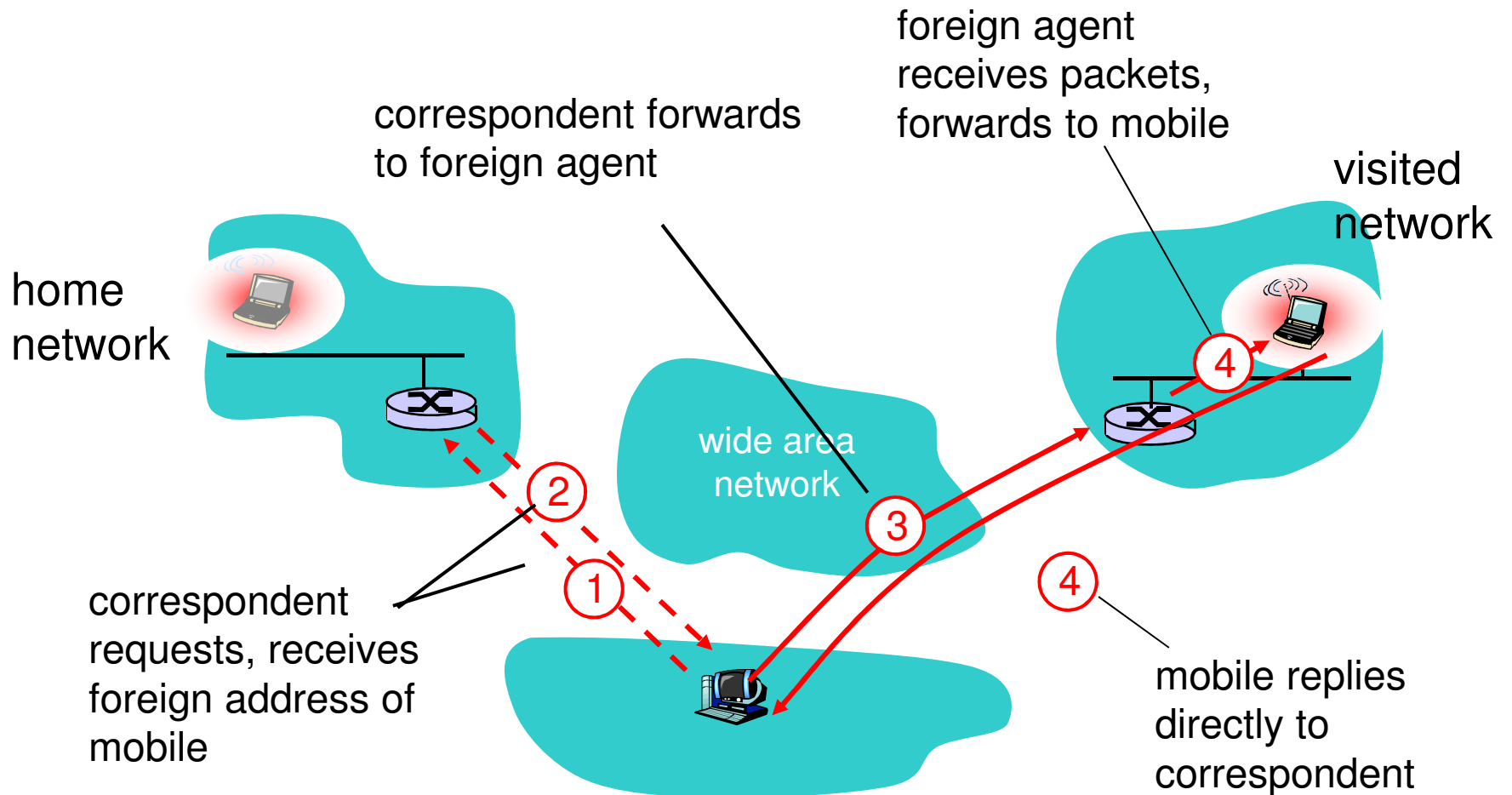

# Mobility via Direct Routing: comments

- overcome triangle routing problem
- **non-transparent to correspondent:**  
correspondent must get care-of-address from home agent
  - what if mobile changes visited network?

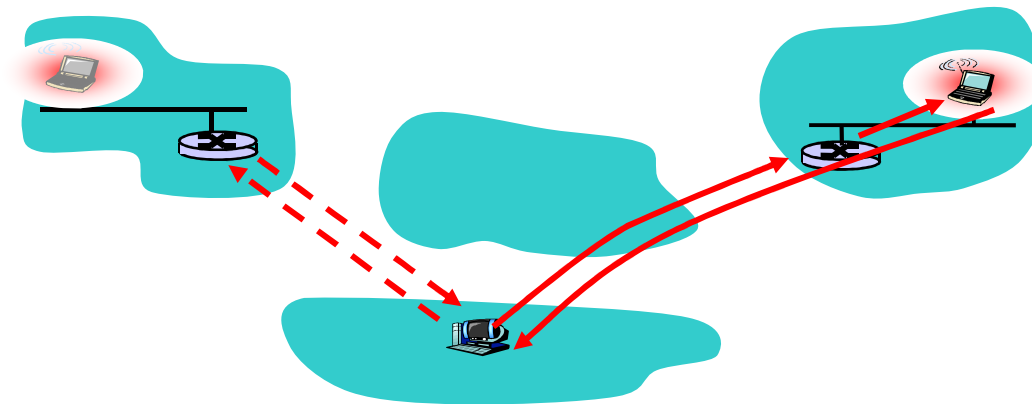

# Accommodating mobility with direct routing

- anchor foreign agent: FA in first visited network
- data always routed first to anchor FA
- when mobile moves: new FA arranges to have data forwarded from old FA (chaining)

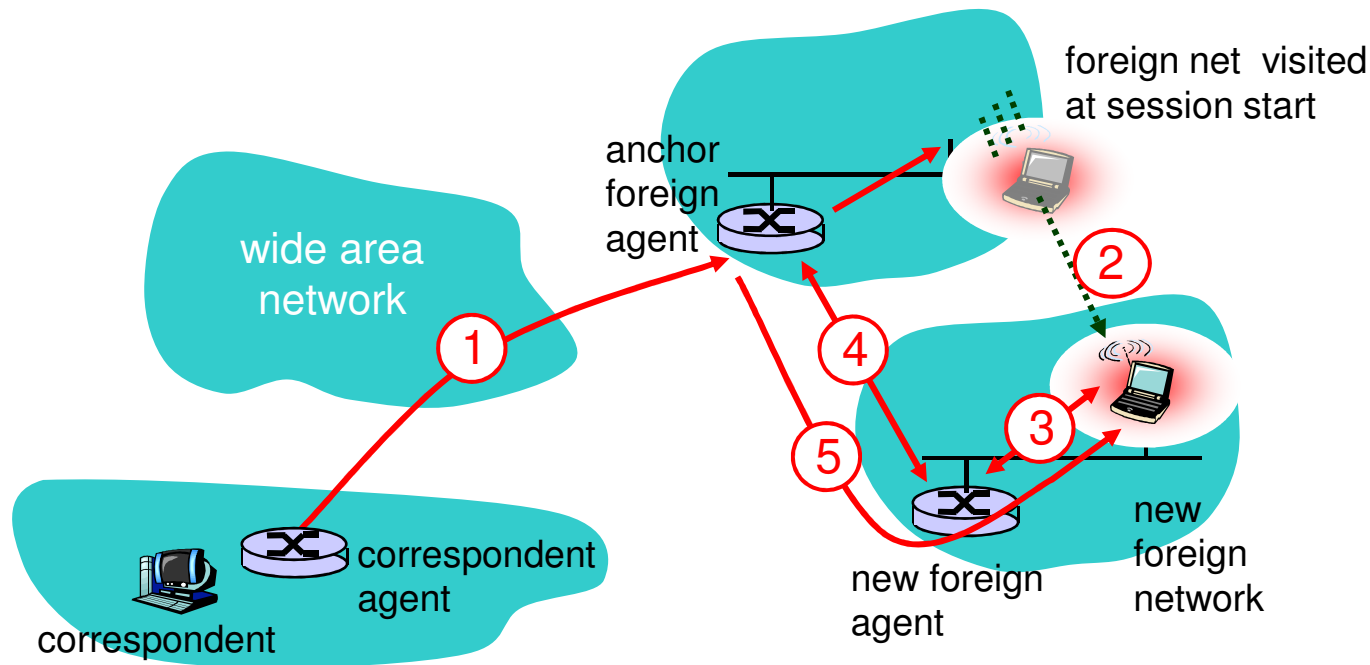

# Network Layer II

- 4.6 Multicast
  - Broadcast routing
  - Multicast routing
  - Multicast routing protocols
- 4.7 Mobility
  - What is Mobility?
  - Network layer mobility concepts and principles
  - Mobile IP

# Mobile IP

- RFC 3344
- has many features we've seen:
  - home agents, foreign agents, foreign-agent registration, care-of-addresses, encapsulation (packet-within-a-packet)
- three components to standard:
  - indirect routing of datagrams
  - agent discovery
  - registration with home agent

# Mobile IP: indirect routing

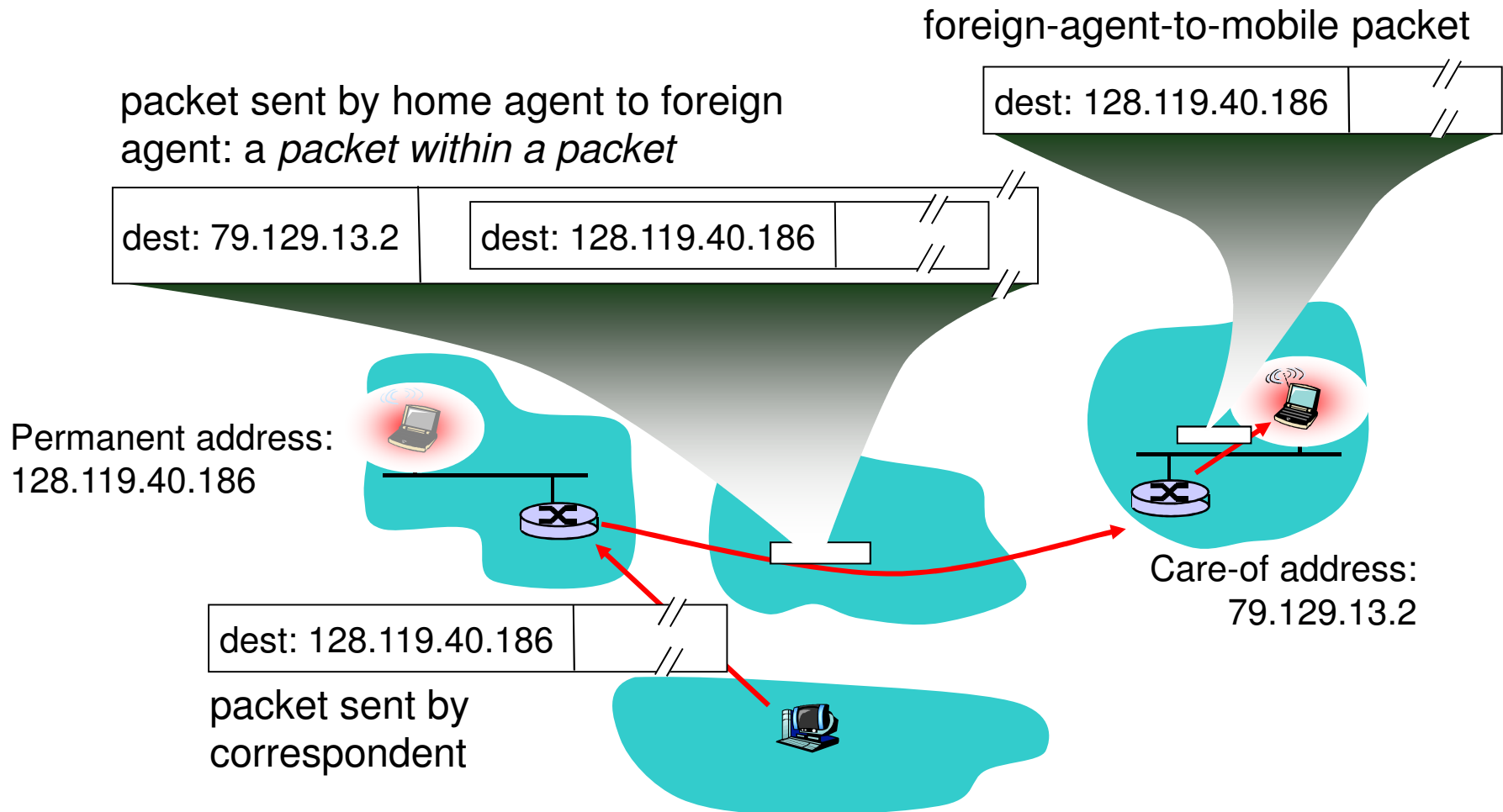

# Mobile IP: agent discovery

- **agent advertisement:** foreign/home agents advertise service by broadcasting ICMP messages (typefield = 9)

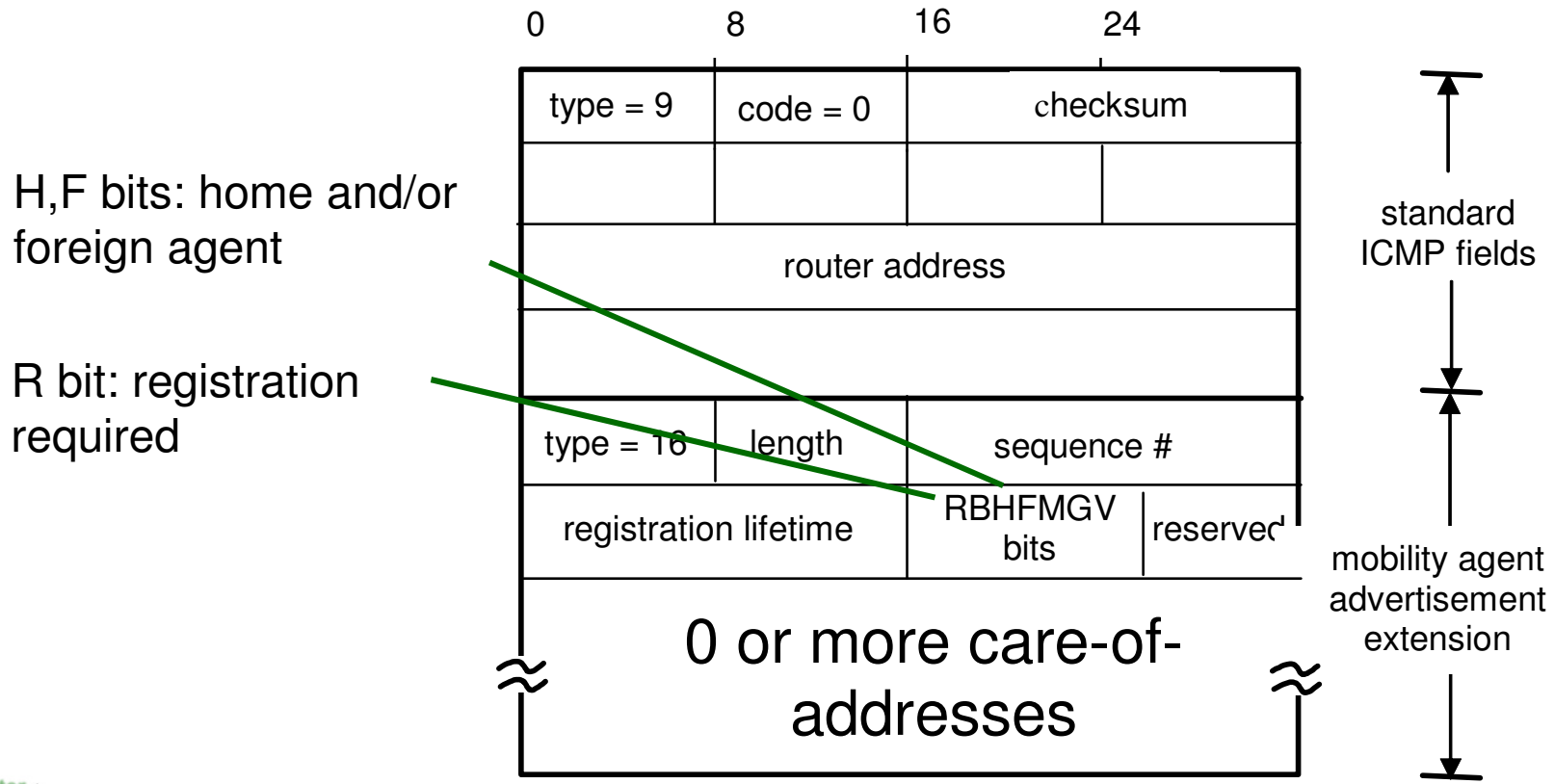

# Mobile IP: registration example

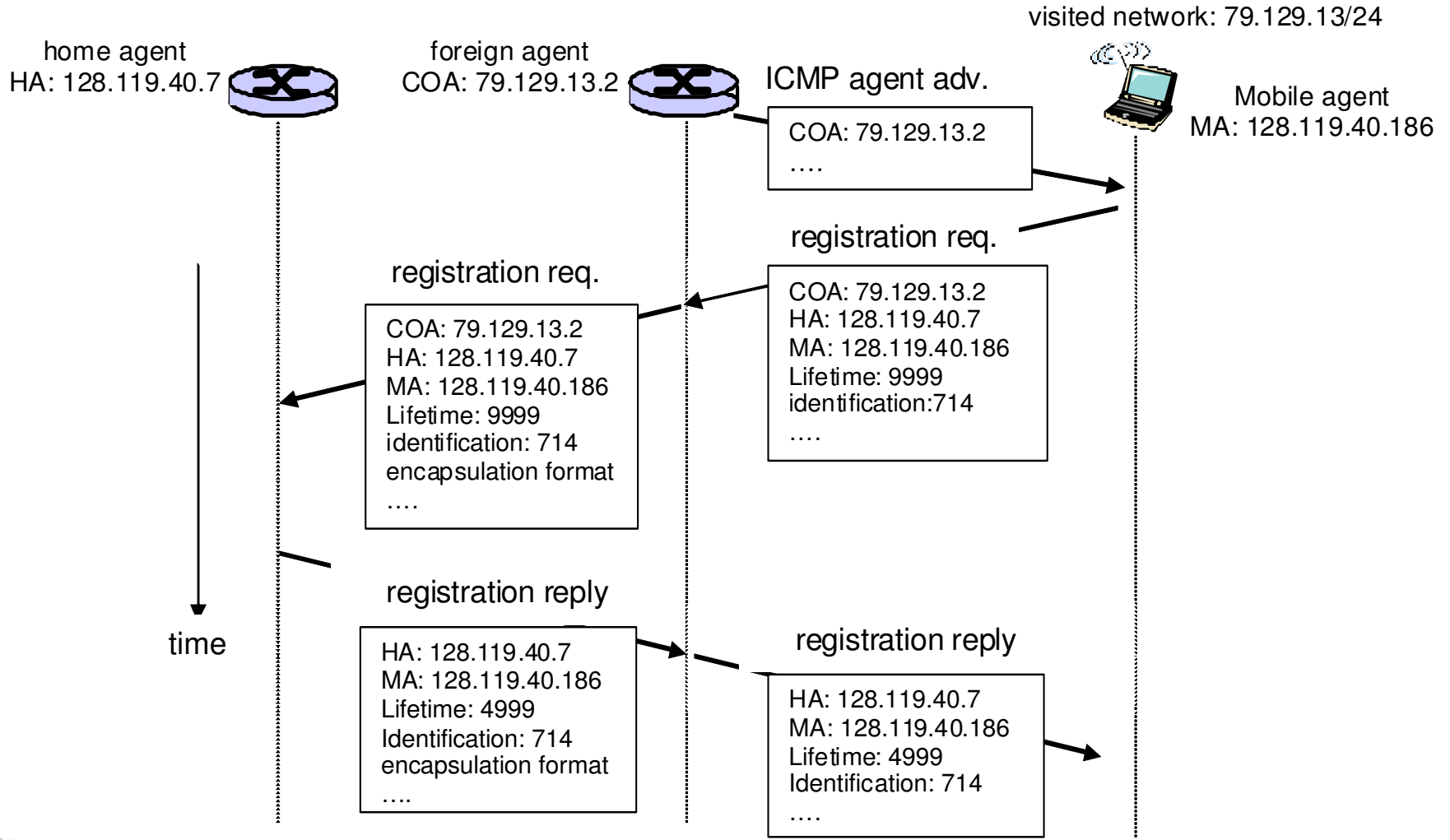



# Thank you

Any questions?

# Thank you

Any questions?