

Network Layer – Part II

Computer Networks, Winter 2015/2016

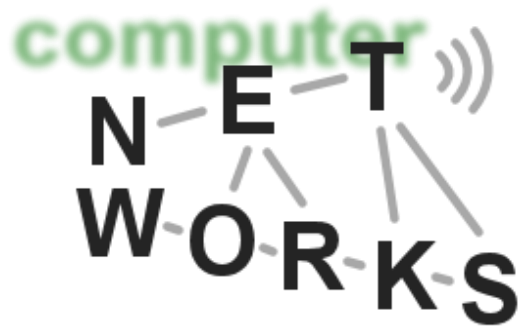

Network Layer II

- 3.4 Routing algorithms
 - Link state
 - Distance Vector
 - Hierarchical routing
- 3.5 Routing protocols
 - Routing Information Protocol (RIP)
 - Open Shortest Path First (OSPF)
 - Border Gateway Protocol (BGP)

Routing, Forwarding, and Switching

- Switching
 - Hardware-based relaying of packets
 - Relies on switching fabric
 - Layer-2 switches, Layer-3 switches
- Forwarding
 - Relaying of packets from input port to output port(s)
 - Based on forwarding table
- Routing
 - Process of configuring the forwarding of a node

Interplay between routing and forwarding

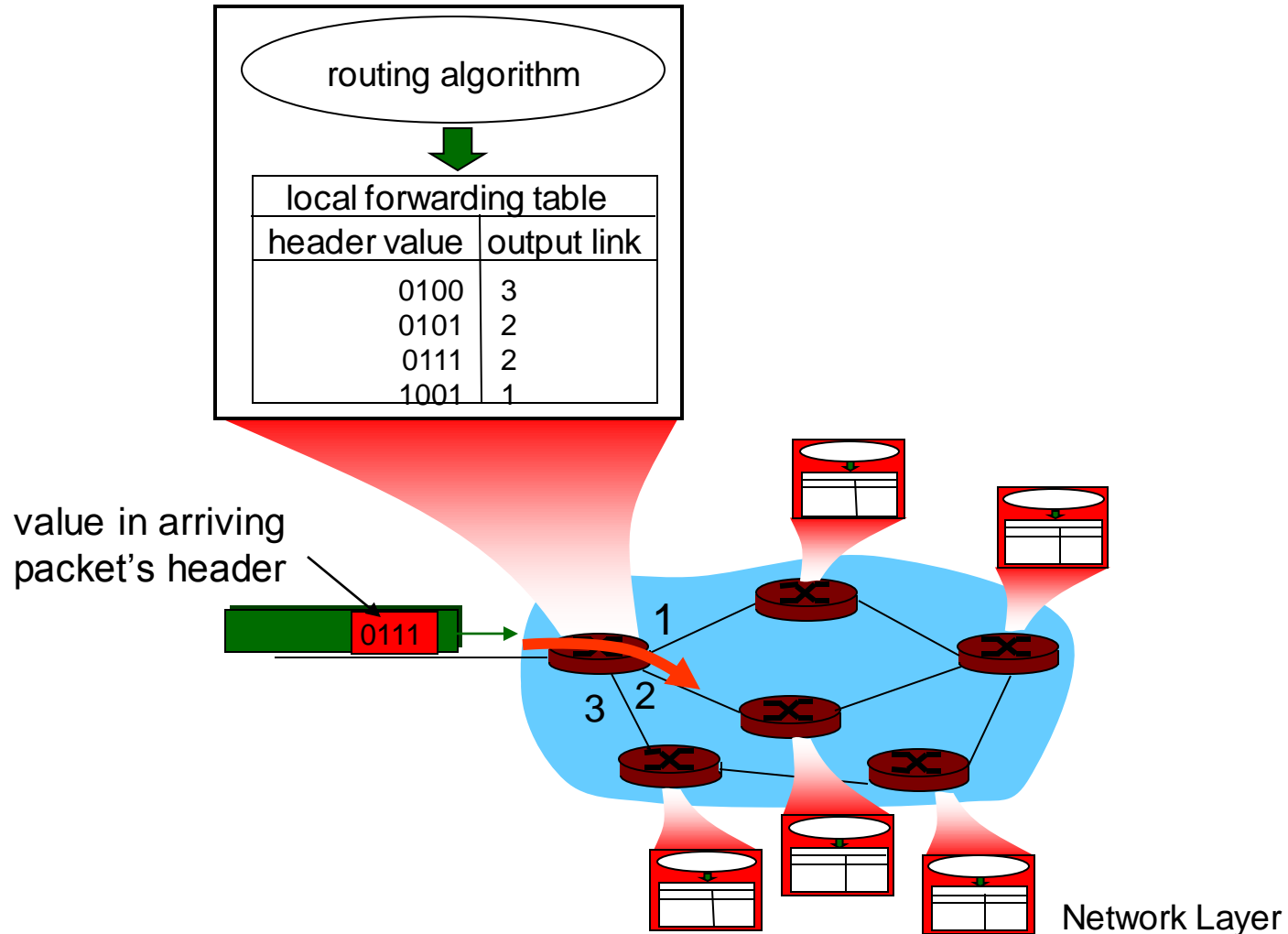

Graph abstraction

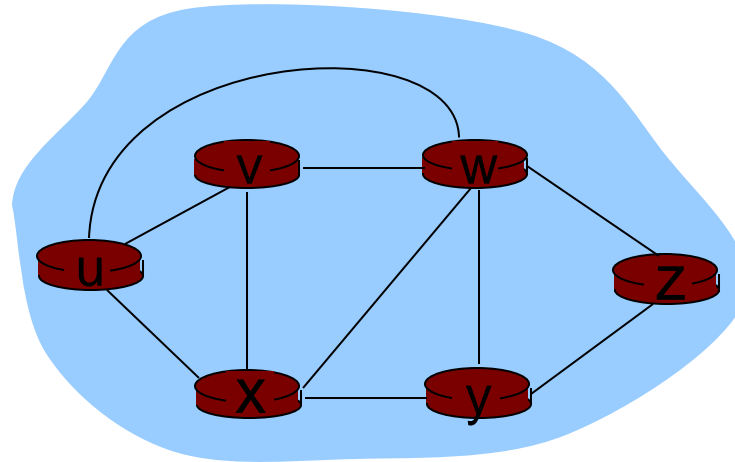

Graph: $G = (N, E)$

$N = \text{set of routers} = \{ u, v, w, x, y, z \}$

$E = \text{set of links} = \{ (u,v), (u,x), (v,x), (v,w), (x,w), (x,y), (w,y), (w,z), (y,z) \}$

Remark: Graph abstraction is useful in other network contexts

Example: P2P, where N is set of peers and E is set of TCP connections

Graph abstraction: costs

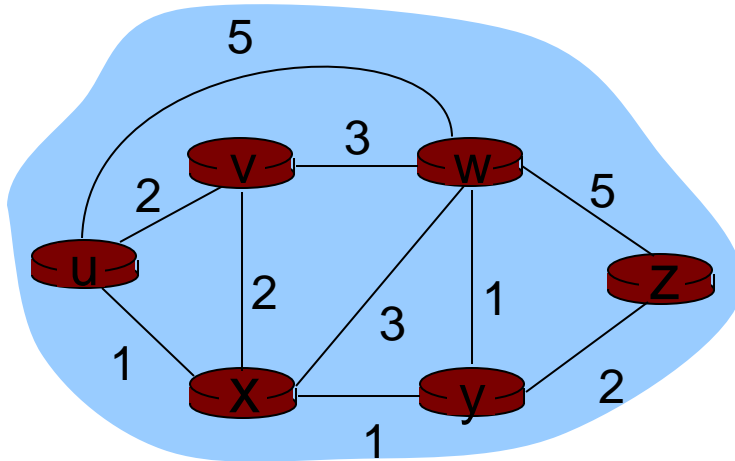

- $c(x,x')$ = cost of link (x,x')

- e.g., $c(w,z) = 5$

- cost could always be 1, or inversely related to bandwidth, or inversely related to congestion

Cost of path $(x_1, x_2, x_3, \dots, x_p) = c(x_1, x_2) + c(x_2, x_3) + \dots + c(x_{p-1}, x_p)$

Question: What's the least-cost path between u and z ?

Routing algorithm: algorithm that finds least-cost path

Routing Algorithm classification

Global or decentralized information?

- **Global:**
 - all routers have complete topology, link cost info
 - “link state” algorithms
- **Decentralized:**
 - router knows physically-connected neighbors, link costs to neighbors
 - iterative process of computation, exchange of info with neighbors
 - “distance vector” algorithms

Static or dynamic?

- **Static:**
 - routes change slowly over time
- **Dynamic:**
 - routes change more quickly
 - periodic update
 - in response to link cost changes

Network Layer II

- 3.4 Routing algorithms
 - Link state
 - Distance Vector
 - Hierarchical routing
- 3.5 Routing protocols
 - Routing Information Protocol (RIP)
 - Open Shortest Path First (OSPF)
 - Border Gateway Protocol (BGP)

A Link-State Routing Algorithm

Dijkstra's algorithm

- net topology, link costs known to all nodes
 - accomplished via “link state broadcast”
 - all nodes have same info
- computes least cost paths from one node (“source”) to all other nodes
 - gives **forwarding table** for that node
- iterative: after k iterations, know least cost path to k dest.'s

Notation

- $c(x,y)$: link cost from node x to y ; $= \infty$ if not direct neighbors
- $D(v)$: current value of cost of path from source to dest. v
- $p(v)$: predecessor node along path from source to v
- N' : set of nodes whose least cost path is definitively known

Dijkstra's Algorithm

1 **Initialization:**

2 $N' = \{u\}$

3 for all nodes v

4 if v adjacent to u

5 then $D(v) = c(u,v)$

6 else $D(v) = \infty$

7

8 **Loop**

9 find w not in N' such that $D(w)$ is a minimum

10 add w to N'

11 update $D(v)$ for all v adjacent to w and not in N' :

12 $D(v) = \min(D(v), D(w) + c(w,v))$

13 /* new cost to v is either old cost to v or known

14 shortest path cost to w plus cost from w to v */

15 **until all nodes in N'**

Dijkstra's algorithm: example

Step	N'	D(v),p(v)	D(w),p(w)	D(x),p(x)	D(y),p(y)	D(z),p(z)
0	u	2,u	5,u	1,u	∞	∞
1	ux	2,u	4,x		2,x	∞
2	uxy	2,u	3,y			4,y
3	uxyv		3,y			4,y
4	uxyvw					4,y
5	uxyvwz					

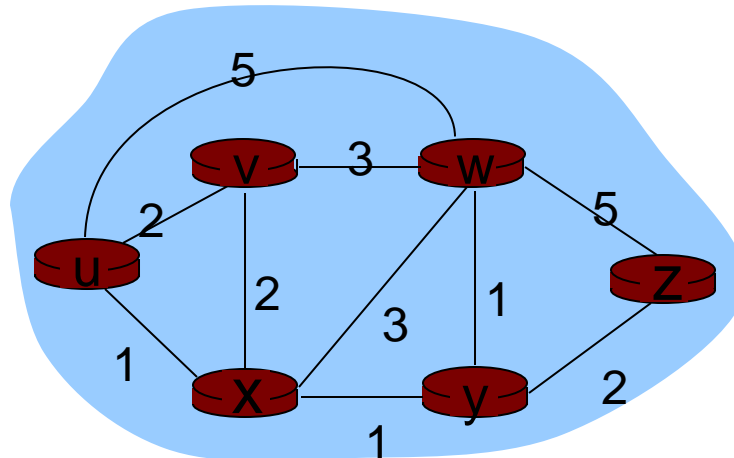

Dijkstra's algorithm: example (2)

Resulting shortest-path tree from u:

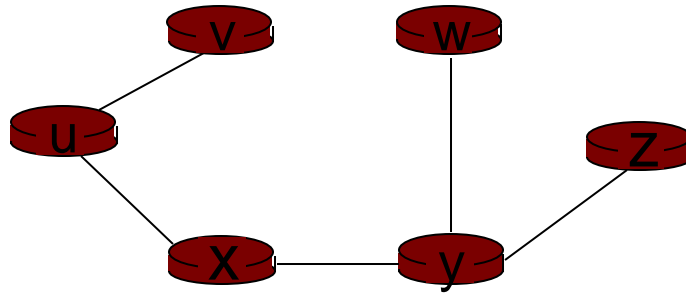

Resulting forwarding table in u:

destination	link
v	(u,v)
x	(u,x)
y	(u,x)
w	(u,x)
z	(u,x)

Dijkstra's algorithm, discussion

Algorithm complexity: n nodes

- each iteration: need to check all nodes, w , not in N
- $n(n+1)/2$ comparisons: $O(n^2)$
- more efficient implementations possible: $O(n \cdot \log(n))$

Oscillations possible:

- e.g., link cost = amount of carried traffic

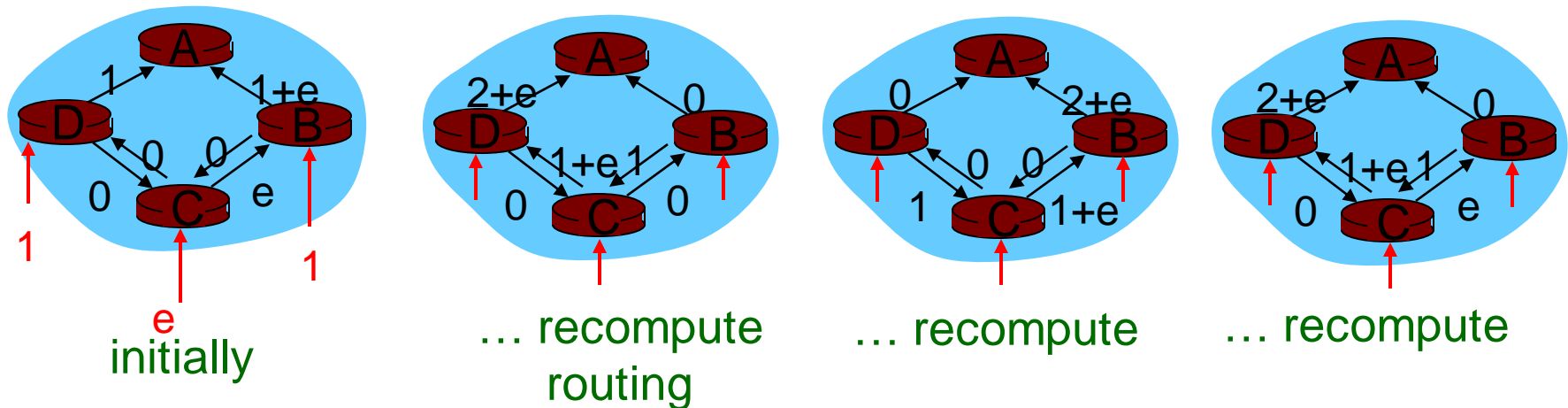

Network Layer II

- 4.4 Routing algorithms
 - Link state
 - Distance Vector
 - Hierarchical routing
- 4.5 Routing protocols
 - Routing Information Protocol (RIP)
 - Open Shortest Path First (OSPF)
 - Border Gateway Protocol (BGP)

Bellman–Ford algorithm

- Finds shortest paths in weighted, directed graph for given source
- Approach: relax all edges repeatedly until stable ($|V| - 1$ times)
- Define
$$d_x(y) := \text{cost of least-cost path from } x \text{ to } y$$
- Then
$$d_x(y) = \min(c(x,v) + d_v(y))$$
where min is taken over all neighbors v of x

Bellman-Ford example

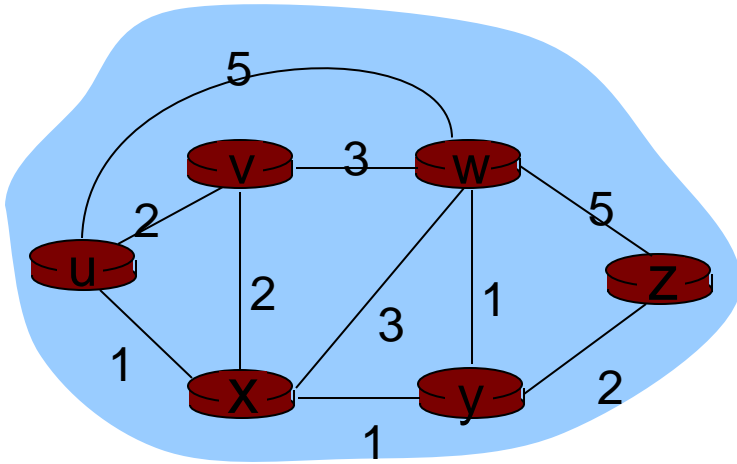

Clearly, $d_v(z) = 5$, $d_x(z) = 3$, $d_w(z) = 3$

B-F equation says:

$$\begin{aligned}d_u(z) &= \min \{ c(u,v) + d_v(z), \\ &\quad c(u,x) + d_x(z), \\ &\quad c(u,w) + d_w(z) \} \\ &= \min \{ 2 + 5, \\ &\quad 1 + 3, \\ &\quad 5 + 3 \} = 4\end{aligned}$$

Node that achieves minimum is next hop in shortest path → forwarding table

Distance Vector Algorithm

- $D_x(y)$ = estimate of least cost from x to y
- Node x knows cost to each neighbor v : $c(x,v)$
- Node x maintains distance vector $\mathbf{D}_x = [D_x(y): y \in N]$
- Node x also maintains its neighbors' distance vectors
 - For each neighbor v , x maintains $\mathbf{D}_v = [D_v(y): y \in N]$

Distance vector algorithm – Basic Idea

- From time-to-time, each node sends its own distance vector estimate to neighbors
- Asynchronous
- When a node x receives new DV estimate from neighbor, it updates its own DV using BF equation
 - $Dx(y) \leftarrow \min_v \{c(x,v) + Dv(y)\}$
for each node $y \in N$
- Under minor, natural conditions, the estimate $Dx(y)$ converge to the actual least cost $dx(y)$

Distance Vector Algorithm (cont'd)

Iterative, asynchronous:

each local iteration caused by:

- local link cost change
- DV update message from neighbor

Distributed:

- each node notifies neighbors *only* when its DV changes
 - neighbors then notify their neighbors if necessary

Each node:

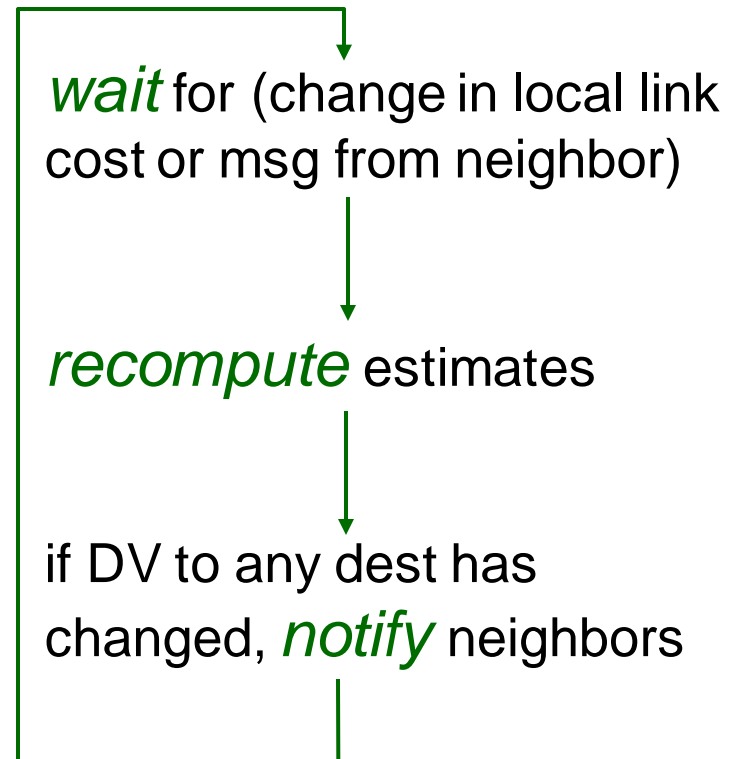

$$D_x(y) = \min\{c(x,y) + D_y(y), c(x,z) + D_z(y)\}$$

$$= \min\{2+0, 7+1\} = 2$$

$$D_x(z) = \min\{c(x,y) + D_y(z), c(x,z) + D_z(z)\}$$

$$= \min\{2+1, 7+0\} = 3$$

node x table

		cost to		
		x	y	z
from	x	0	2	7
	y	∞	∞	∞
	z	∞	∞	∞

		cost to		
		x	y	z
from	x	0	2	3
	y	2	0	1
	z	7	1	0

node y table

		cost to		
		x	y	z
from	x	∞	∞	∞
	y	2	0	1
	z	∞	∞	∞

node z table

		cost to		
		x	y	z
from	x	∞	∞	∞
	y	∞	∞	∞
	z	7	1	0

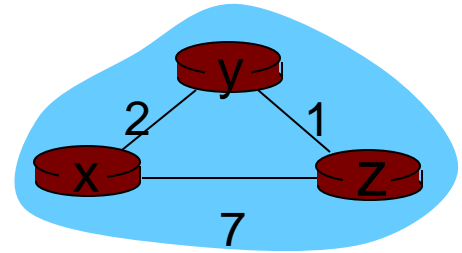

$$D_x(y) = \min\{c(x,y) + D_y(y), c(x,z) + D_z(y)\}$$

$$= \min\{2+0, 7+1\} = 2$$

$$D_x(z) = \min\{c(x,y) + D_y(z), c(x,z) + D_z(z)\}$$

$$= \min\{2+1, 7+0\} = 3$$

node x table

		cost to		
		x	y	z
from	x	0	2	7
	y	∞	∞	∞
	z	∞	∞	∞

node y table

		cost to		
		x	y	z
from	x	∞	∞	∞
	y	2	0	1
	z	∞	∞	∞

node z table

		cost to		
		x	y	z
from	x	∞	∞	∞
	y	∞	∞	∞
	z	7	1	0

		cost to		
		x	y	z
from	x	0	2	3
	y	2	0	1
	z	7	1	0

		cost to		
		x	y	z
from	x	0	2	7
	y	2	0	1
	z	7	1	0

		cost to		
		x	y	z
from	x	0	2	7
	y	2	0	1
	z	3	1	0

		cost to		
		x	y	z
from	x	0	2	3
	y	2	0	1
	z	3	1	0

		cost to		
		x	y	z
from	x	0	2	3
	y	2	0	1
	z	3	1	0

		cost to		
		x	y	z
from	x	0	2	3
	y	2	0	1
	z	3	1	0

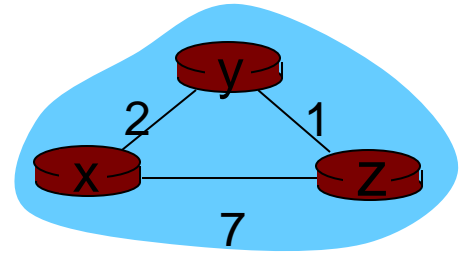

Distance Vector: link cost changes

Link cost changes:

- node detects local link cost change
- updates routing info, recalculates distance vector
- if DV changes, notify neighbors

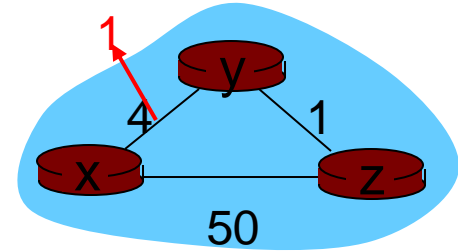

“good
news
travels
fast”

At time t_0 , y detects the link-cost change, updates its DV, and informs its neighbors.

At time t_1 , z receives the update from y and updates its table. It computes a new least cost to x and sends its neighbors its DV.

At time t_2 , y receives z 's update and updates its distance table. y 's least costs do not change and hence y does *not* send any message to z .

Distance Vector: link cost changes

Link cost changes:

- good news travels fast
- bad news travels slow - “count to infinity” problem!
- 44 iterations before algorithm stabilizes: see textbook

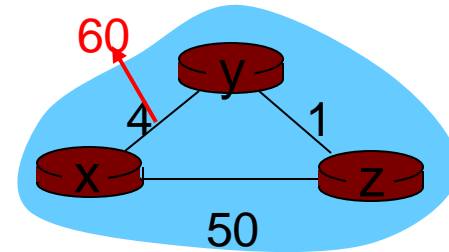

Poisoned reverse:

- If Z routes through Y to get to X :
 - Z tells Y its (Z's) distance to X is infinite (so Y won't route to X via Z)

Comparison of LS and DV algorithms

Message complexity

- LS: with n nodes, E links, $O(nE)$ msgs sent
- DV: exchange between neighbors only
 - convergence time varies

Speed of Convergence

- LS: $O(n^2)$ algorithm requires $O(nE)$ msgs
 - may have oscillations
- DV: convergence time varies
 - may be routing loops
 - count-to-infinity problem

Robustness: what happens if router malfunctions?

LS:

- node can advertise incorrect *link* cost
- each node computes only its *own* table

DV:

- DV node can advertise incorrect *path* cost
- each node's table used by others
 - error propagate through network

Network Layer II

- 3.4 Routing algorithms
 - Link state
 - Distance Vector
 - Hierarchical routing
- 3.5 Routing protocols
 - Routing Information Protocol (RIP)
 - Open Shortest Path First (OSPF)
 - Border Gateway Protocol (BGP)

Hierarchical Routing

- Our routing study thus far - idealization
 - all routers identical
 - network “flat”
 - ... not true in practice
- **Scale:** with 200 million destinations:
 - can't store all dest's in routing tables
 - routing table exchange would swamp links
- **Administrative autonomy**
 - internet = network of networks
 - each network admin may want to control routing in its own network

Hierarchical Routing

- Aggregate routers into regions
 - Autonomous Systems (AS)
- Routers in same AS run same routing protocol
 - “intra-AS” routing protocol
 - routers in different AS can run different intra-AS routing protocol
- Gateway router
 - Direct link to router in another AS

Interconnected ASes

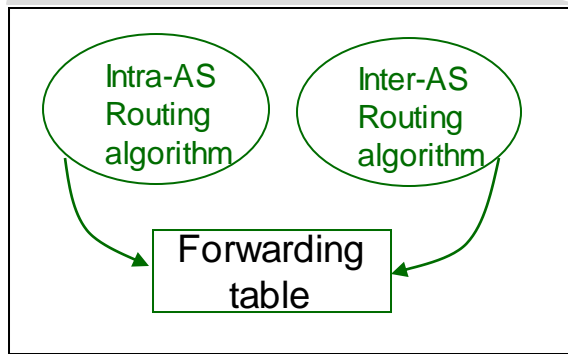
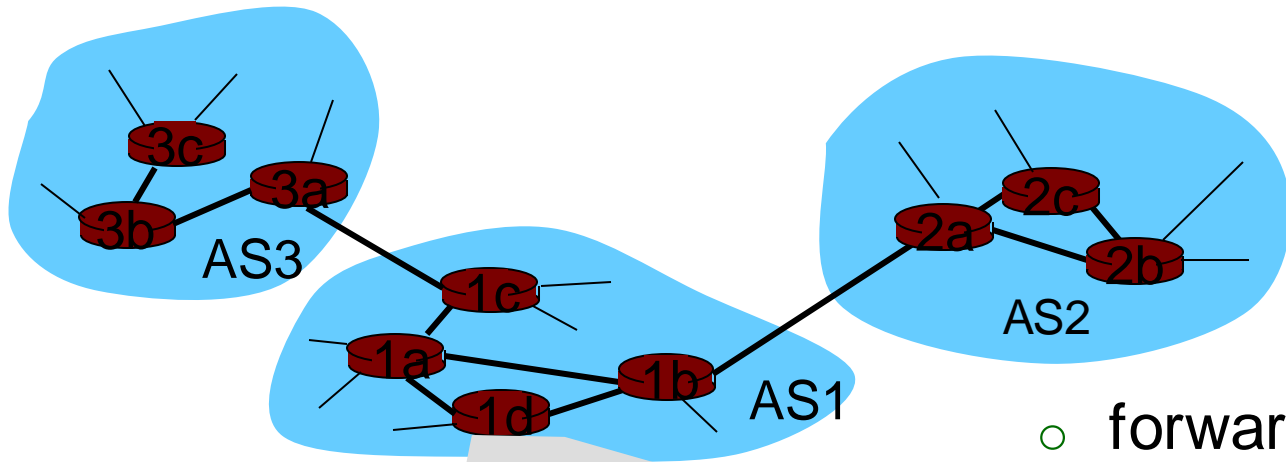

- forwarding table configured by both intra- and inter-AS routing algorithm
 - intra-AS sets entries for internal dests
 - inter-AS & intra-AS sets entries for external dests

Inter-AS tasks

- suppose router in AS1 receives datagram destined outside of AS1:
 - router should forward packet to gateway router, but which one?

AS1 must:

1. learn which dests are reachable through AS2, which through AS3
2. propagate this reachability info to all routers in AS1

Job of inter-AS routing!

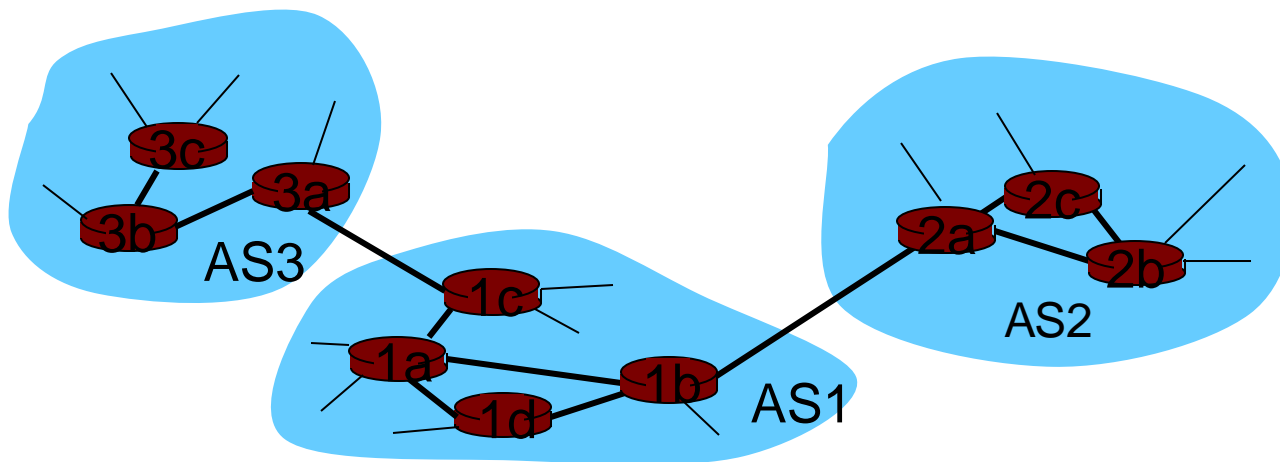

Example: Setting forwarding table in router 1d

- suppose AS1 learns (via inter-AS protocol) that subnet x reachable via AS3 (gateway 1c) but not via AS2.
- inter-AS protocol propagates reachability info to all internal routers.
- router 1d determines from intra-AS routing info that its interface l is on the least cost path to 1c.
 - installs forwarding table entry (x, l)

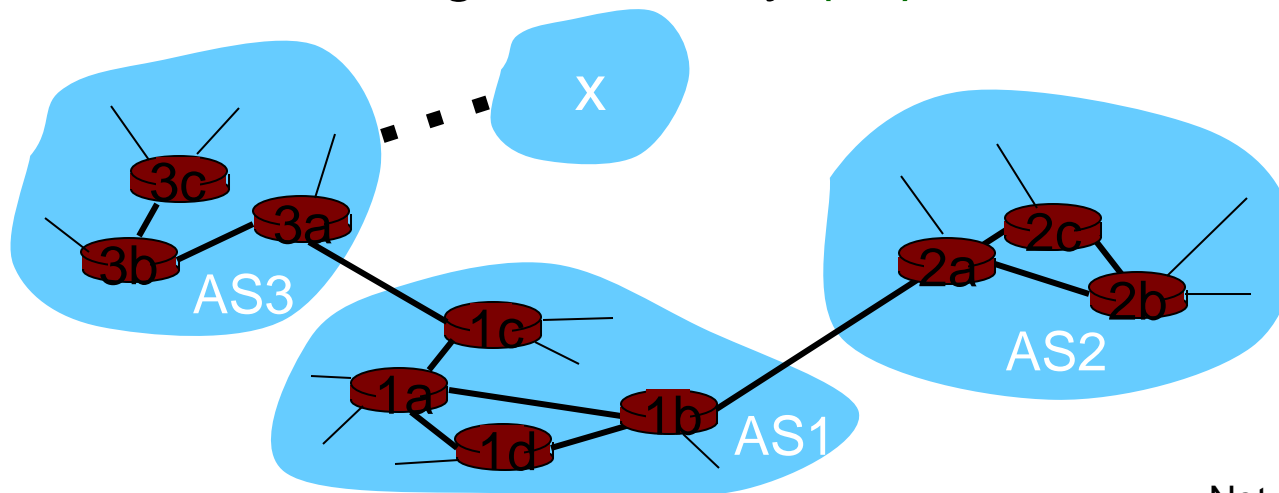

Example: Choosing among multiple ASes

- now suppose AS1 learns from inter-AS protocol that subnet **x** is reachable from AS3 *and* from AS2.
- to configure forwarding table, router 1d must determine towards which gateway it should forward packets for dest **x**.
 - this is also job of inter-AS routing protocol!

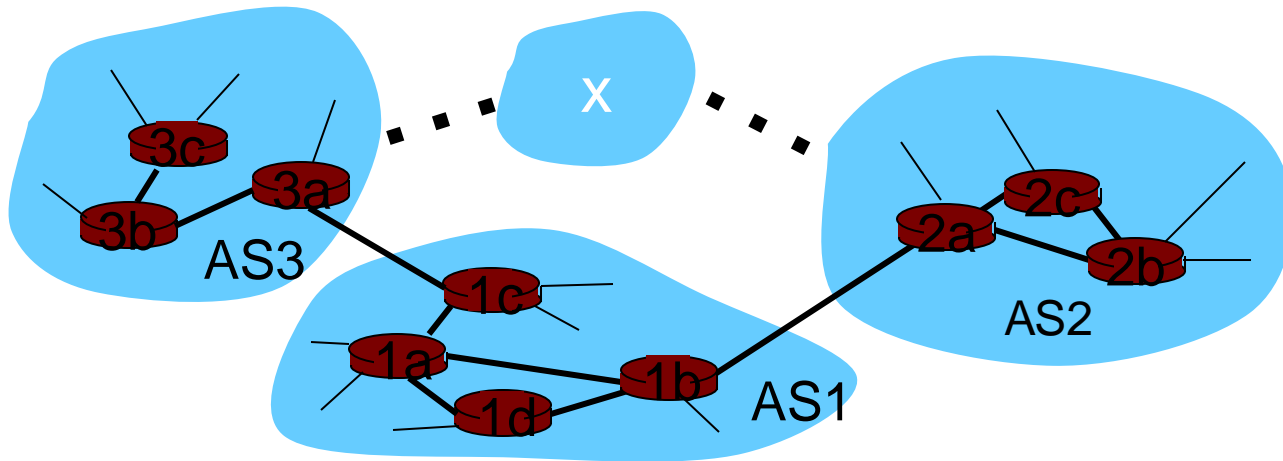

Example: Choosing among multiple ASes

- now suppose AS1 learns from inter-AS protocol that subnet x is reachable from AS3 *and* from AS2.
- to configure forwarding table, router 1d must determine towards which gateway it should forward packets for dest x .
 - this is also job of inter-AS routing protocol!
- **hot potato routing**: send packet towards closest of two routers.

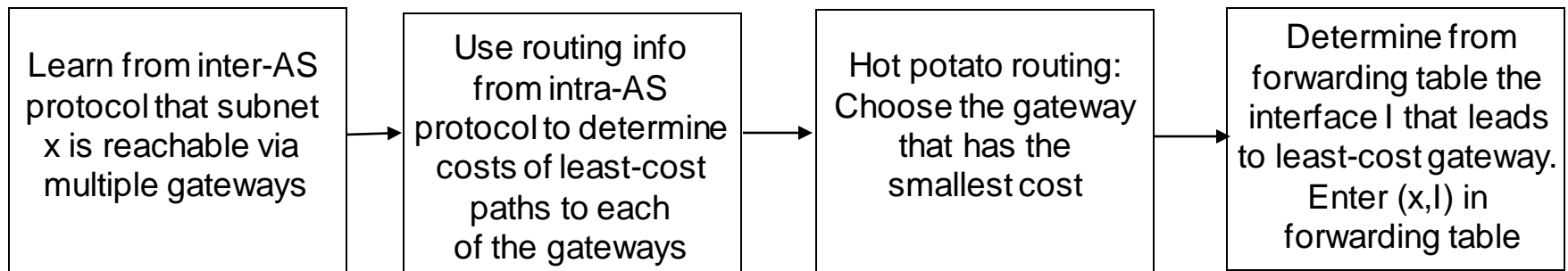

Network Layer II

- 3.4 Routing algorithms
 - Link state
 - Distance Vector
 - Hierarchical routing
- 3.5 Routing protocols
 - Routing Information Protocol (RIP)
 - Open Shortest Path First (OSPF)
 - Border Gateway Protocol (BGP)

Routing Protocols

- **Intra-AS routing** aka Interior Gateway Protocols (IGP)
 - Routing Information Protocol (RIP)
 - Open Shortest Path First (OSPF)
 - Interior Gateway Routing Protocol (IGRP) (Cisco proprietary)
- **Inter-AS routing**
 - Border Gateway Protocol (BGP)
 - Exterior Gateway Protocol (EGP)

Network Layer II

- 3.4 Routing algorithms
 - Link state
 - Distance Vector
 - Hierarchical routing
- 3.5 Routing protocols
 - Routing Information Protocol (RIP)
 - Open Shortest Path First (OSPF)
 - Border Gateway Protocol (BGP)

Routing Information Protocol (RIP)

- distance vector algorithm
- included in BSD-UNIX Distribution in 1982
- distance metric: # of hops (max = 15 hops)

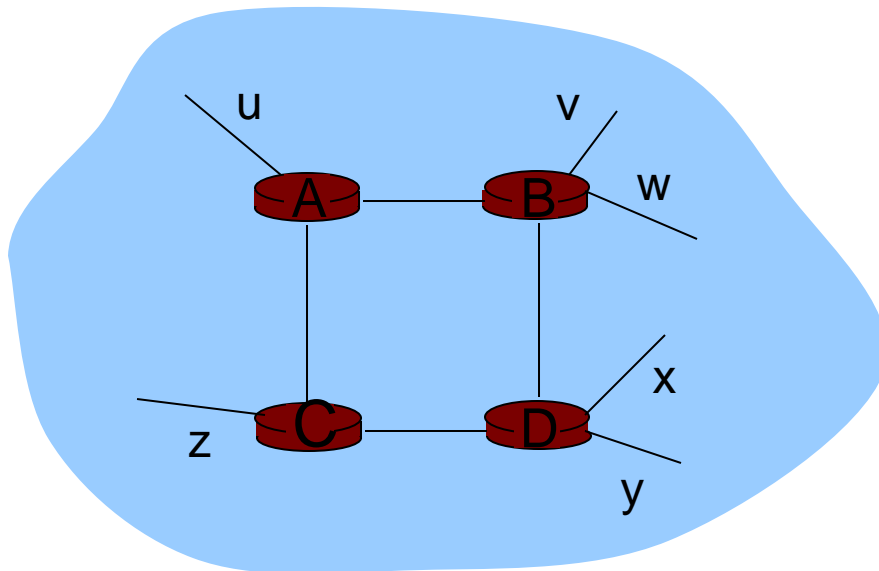

From router A to subnets:

<u>destination</u>	<u>hops</u>
u	1
v	2
w	2
x	3
y	3
z	2

RIP advertisements

- distance vectors
 - exchanged among neighbors every 30 sec via Response Message (also called *advertisement*)
- each advertisement: list of up to 25 destination subnets within AS

RIP: Example

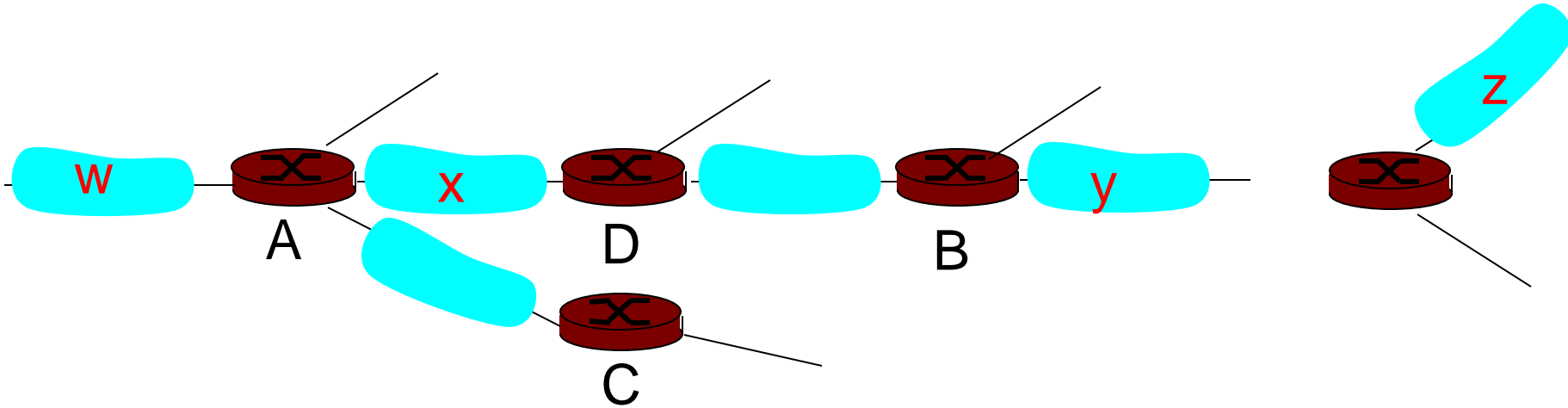

Destination Network	Next Router	Num. of hops to dest.
W	A	2
y	B	2
z	B	7
x	--	1
....

Routing/Forwarding table in D

RIP: Example

Dest	Next	hops
w	-	1
x	-	1
z	C	4
....

Advertisement from A to D

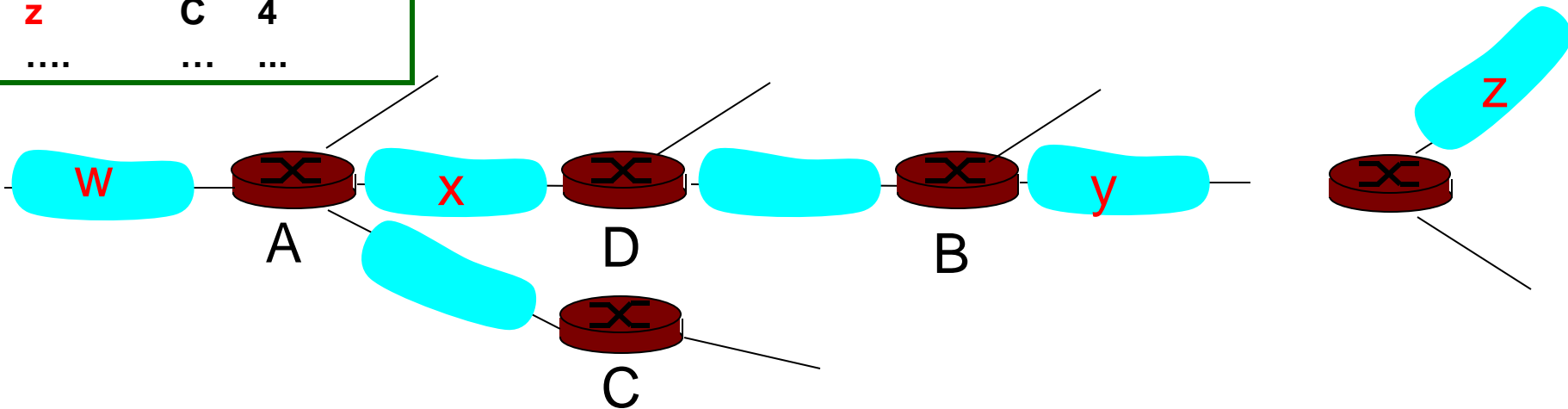

Destination Network	Next Router	Num. of hops to dest.
w	A	2
y	B	2
z	B A	7 5
x	--	1
....

Routing/Forwarding table in D

RIP: Link Failure and Recovery

- If no advertisement heard after 180 sec: neighbor/link declared dead
 - routes via neighbor invalidated
 - new advertisements sent to neighbors
 - neighbors in turn send out new advertisements (if tables changed)
 - link failure info quickly (?) propagates to entire net
 - **poison reverse** used to prevent ping-pong loops (infinite distance = 16 hops)

RIP Table processing

- RIP routing tables managed by **application-level** process called route-d (daemon)
- advertisements sent in UDP packets, periodically repeated

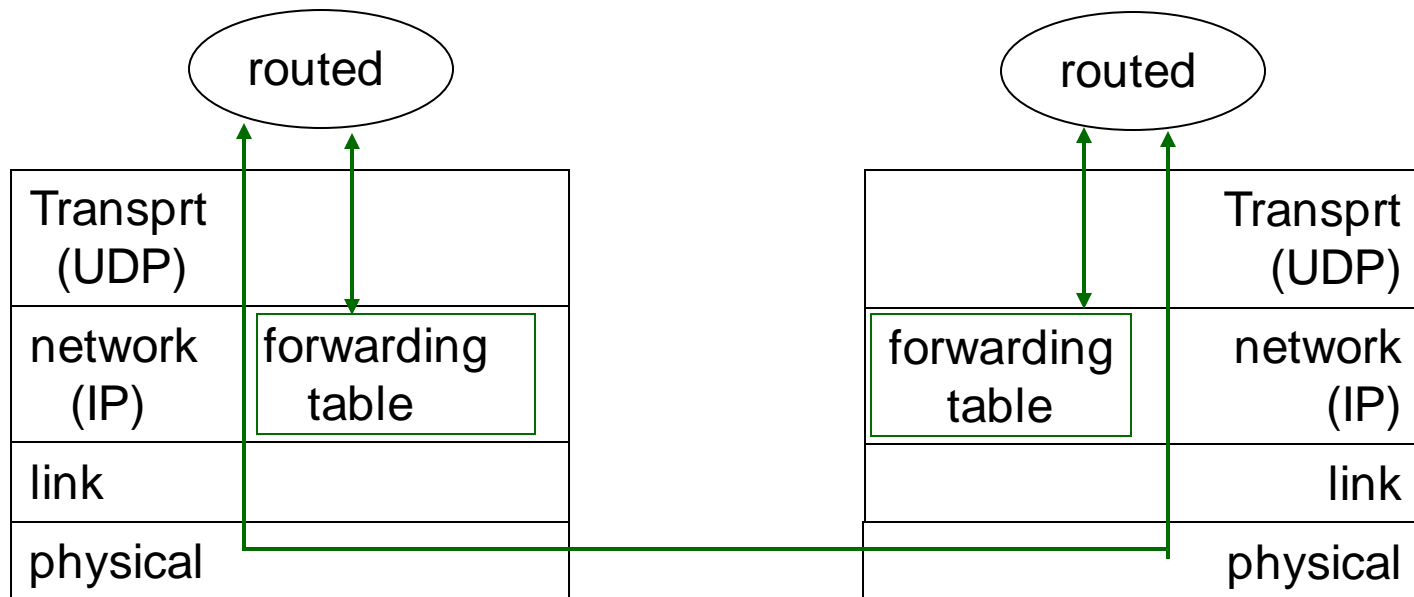

Network Layer II

- 3.4 Routing algorithms
 - Link state
 - Distance Vector
 - Hierarchical routing
- 3.5 Routing protocols
 - Routing Information Protocol (RIP)
 - Open Shortest Path First (OSPF)
 - Border Gateway Protocol (BGP)

Open Shortest Path First (OSPF)

- “open”: publicly available
- uses Link State algorithm
 - LS packet dissemination
 - topology map at each node
 - route computation using Dijkstra’s algorithm
- OSPF advertisement carries one entry per neighbor router
- advertisements disseminated to entire AS (via flooding)
 - carried in OSPF messages directly over IP (rather than TCP or UDP)

OSPF “advanced” features (not in RIP)

- **Security**: all OSPF messages authenticated (to prevent malicious intrusion)
- **multiple** same-cost **paths** allowed
- For each link, multiple cost metrics for different **TOS**
- Integrated uni- and **multicast** support:
 - Multicast OSPF (MOSPF) uses same topology data base as OSPF
- **Hierarchical** OSPF in large domains.

Hierarchical OSPF

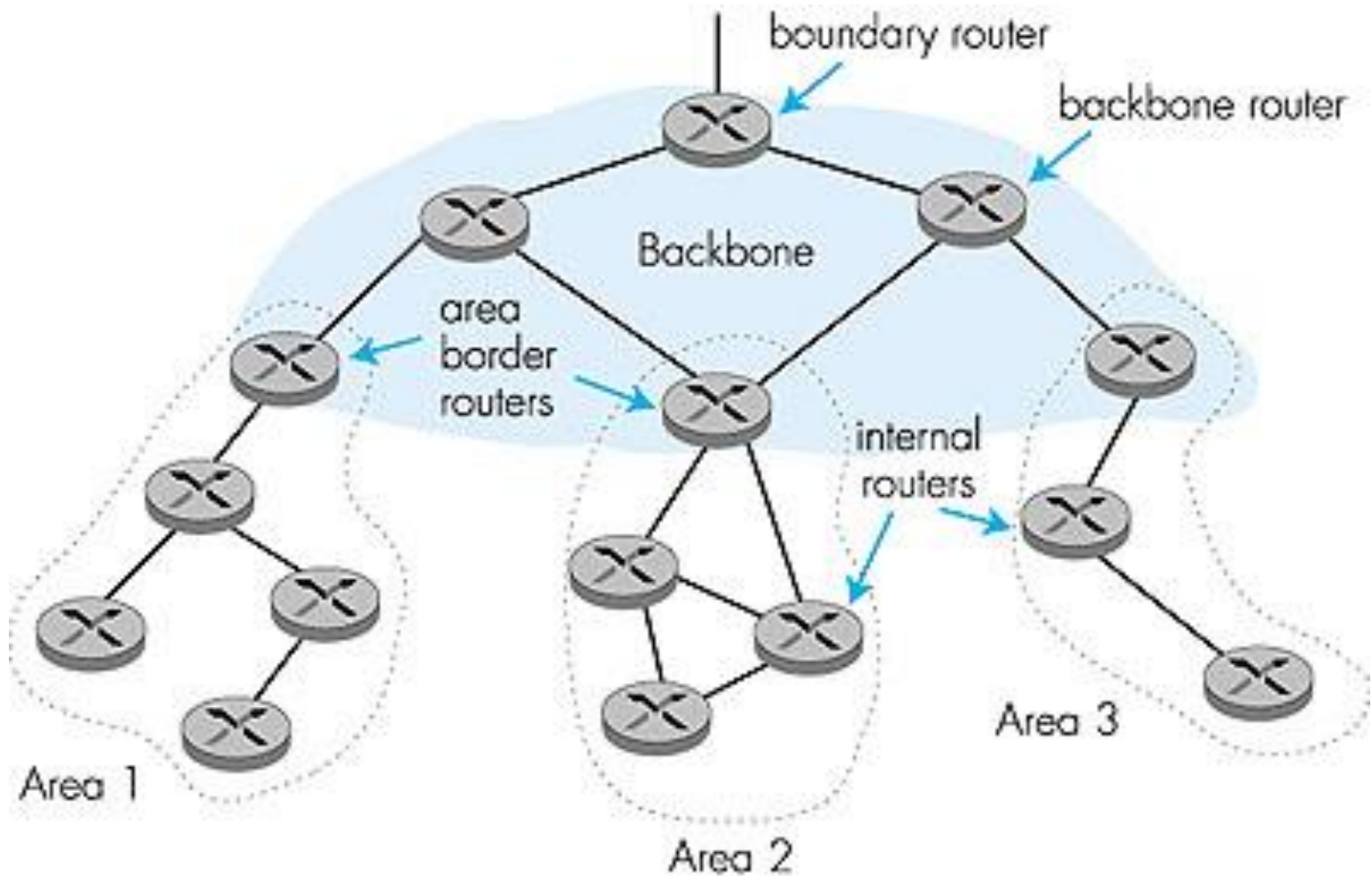

Hierarchical OSPF

- **two-level hierarchy:** local area, backbone.
 - Link-state advertisements only in area
 - each node has detailed area topology; only know direction (shortest path) to nets in other areas.
- **area border routers:** “summarize” distances to nets in own area, advertise to other Area Border routers.
- **backbone routers:** run OSPF routing limited to backbone.
- **boundary routers:** connect to other AS's.

Network Layer II

- 3.4 Routing algorithms
 - Link state
 - Distance Vector
 - Hierarchical routing
- 3.5 Routing protocols
 - Routing Information Protocol (RIP)
 - Open Shortest Path First (OSPF)
 - Border Gateway Protocol (BGP)

Inter-AS routing: BGP

- BGP (Border Gateway Protocol): the de facto standard
- BGP provides each AS means to:
 - Obtain subnet reachability information from neighboring ASs.
 - Propagate reachability information to all AS-internal routers.
 - Determine “good” routes to subnets based on reachability information and policy.
- allows subnet to advertise its existence to rest of Internet: “I am here”

BGP basics

- pairs of routers (BGP peers) exchange routing info over **BGP sessions** (semi-permanent TCP connections):
 - BGP sessions need not correspond to physical links.
- when AS2 advertises a prefix to AS1:
 - AS2 *promises* it will forward datagrams towards that prefix.
 - AS2 can aggregate prefixes in its advertisement

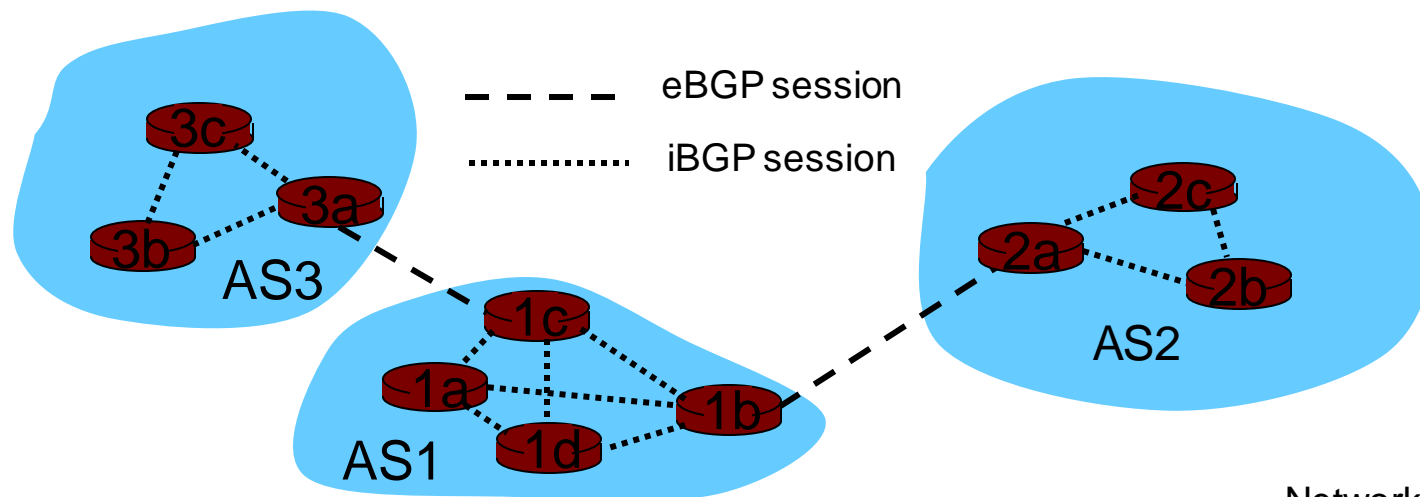

Distributing reachability info

- using eBGP session between 3a and 1c, AS3 sends prefix reachability info to AS1.
 - 1c can then use iBGP to distribute new prefix info to all routers in AS1
 - 1b can then re-advertise new reachability info to AS2 over 1b-to-2a eBGP session
- when router learns of new prefix, it creates entry for prefix in its forwarding table.

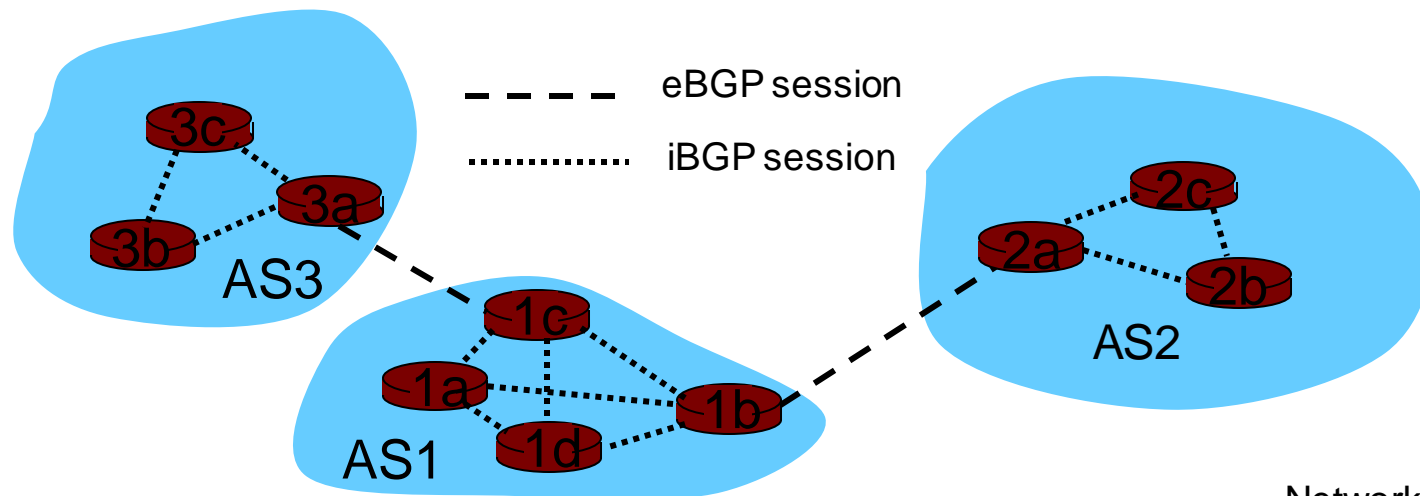

Path attributes & BGP routes

- advertised prefix includes BGP attributes.
 - prefix + attributes = “route”
- two important attributes:
 - **AS-PATH**: contains ASs through which prefix advertisement has passed: e.g, AS 67, AS 17
 - **NEXT-HOP**: indicates specific internal-AS router to next-hop AS. (may be multiple links from current AS to next-hop-AS)
- when gateway router receives route advertisement, uses **import policy** to accept/decline.

BGP route selection

- Router may learn about more than 1 route to same prefix:
 - Router must select route
- Elimination rules:
 - Local preference value attribute: policy decision
 - Shortest AS-PATH
 - Closest NEXT-HOP router: hot potato routing
 - Additional criteria

BGP messages

- BGP messages exchanged using TCP
- BGP messages:
 - OPEN: opens TCP connection to peer and authenticates sender
 - UPDATE: advertises new path (or withdraws old)
 - KEEPALIVE keeps connection alive in absence of UPDATES; also ACKs OPEN request
 - NOTIFICATION: reports errors in previous msg; also used to close connection

BGP routing policy

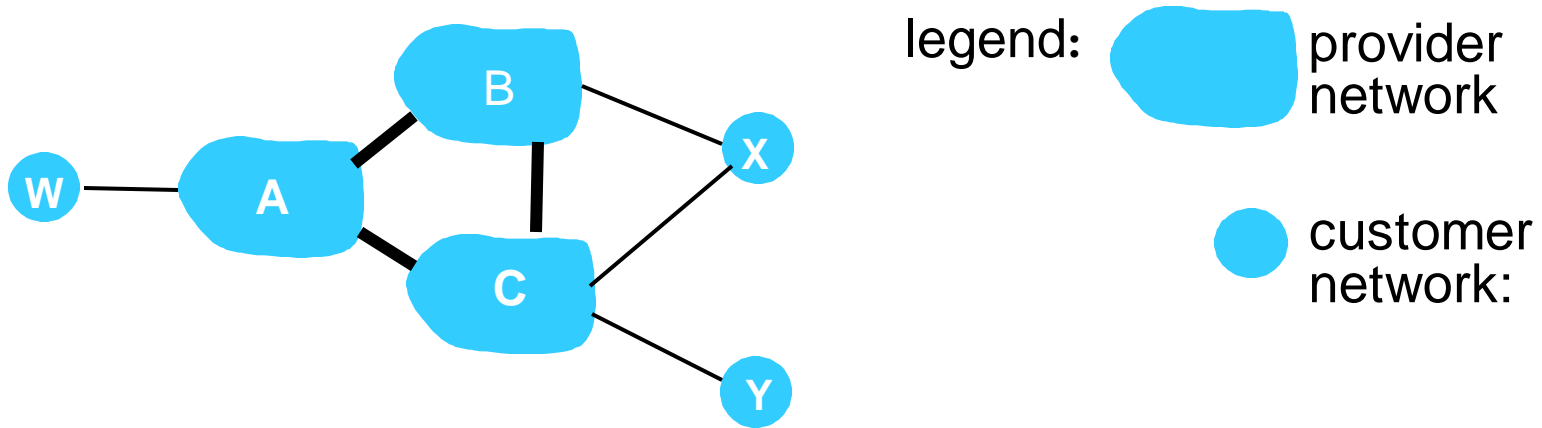

- A,B,C are provider networks
- X,W,Y are customer networks
- X is dual-homed: attached to two networks
 - X does not want to route from B via X to C
 - .. so X will not advertise to B a route to C

BGP routing policy (2)

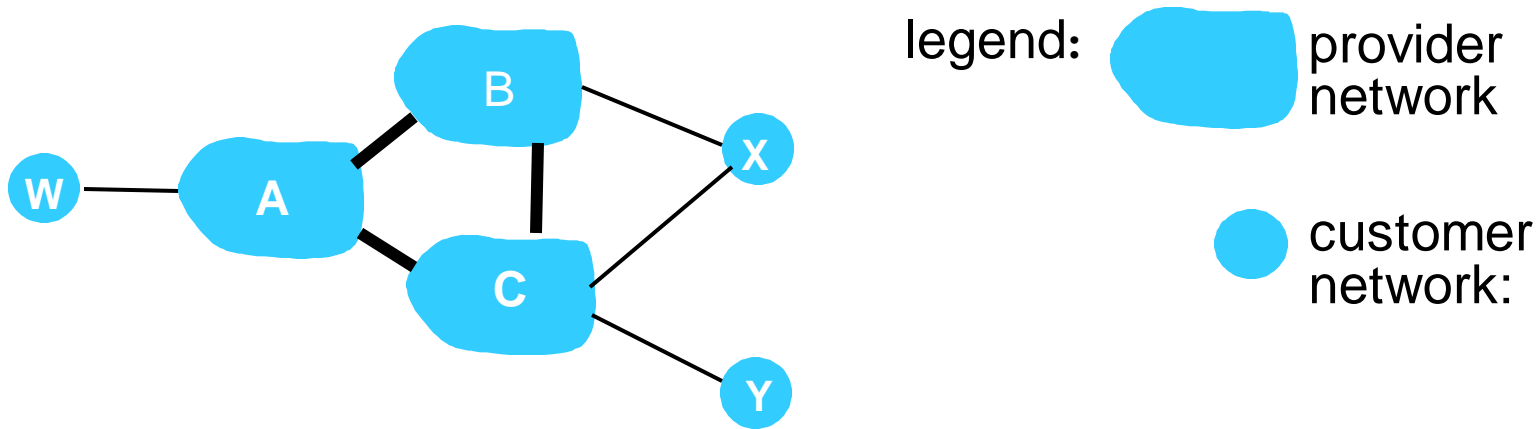

- A advertises path AW to B
- B advertises path BAW to X
- Should B advertise path BAW to C?
 - No way! B gets no “revenue” for routing CBAW since neither W nor C are B’s customers
 - B wants to force C to route to w via A
 - B wants to route *only* to/from its customers!

Why different Intra- and Inter-AS routing?

- Policy
 - Inter-AS: admin wants control over how its traffic routed, who routes through its net.
 - Intra-AS: single admin, so no policy decisions needed
- Scale
 - hierarchical routing saves table size, reduced update traffic
- Performance
 - Intra-AS: can focus on performance
 - Inter-AS: policy may dominate over performance

Current Research

- Software-defined networking
- BGP: mainly security issues

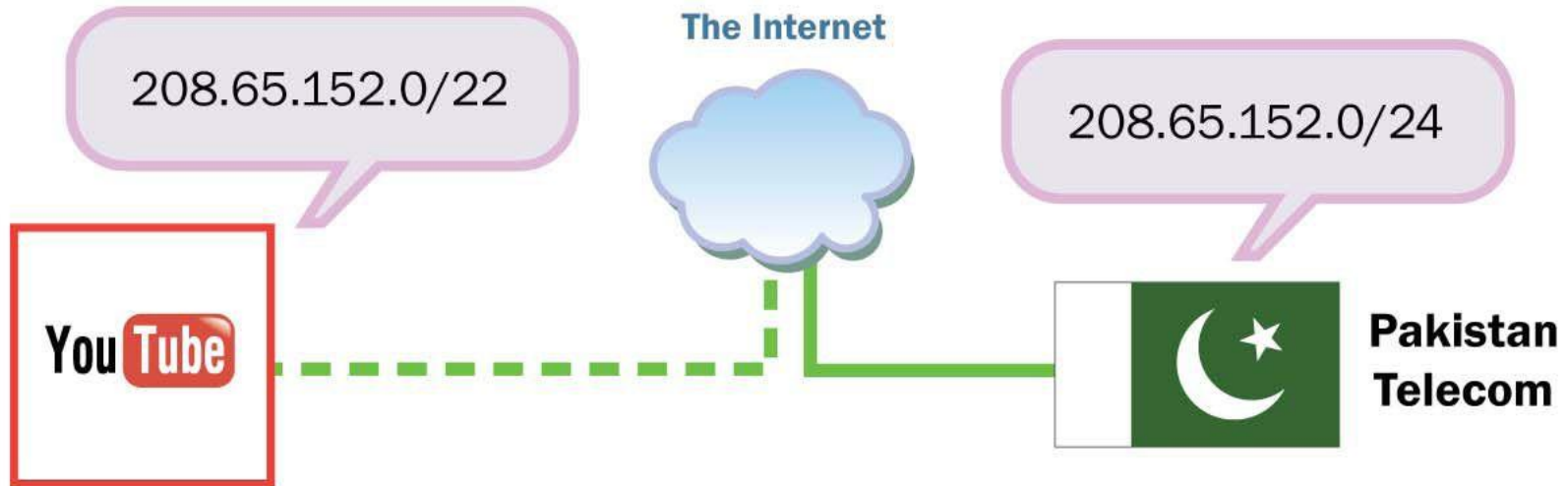

Thank you

Any questions?