

Transport Layer – Part II

Computer Networks, Winter 2020/2021

Lecturer: Prof. Xiaoming Fu

Assistants: Yachao Shao (MSc),

Fabian Wölk (MSc)

Last Session

1

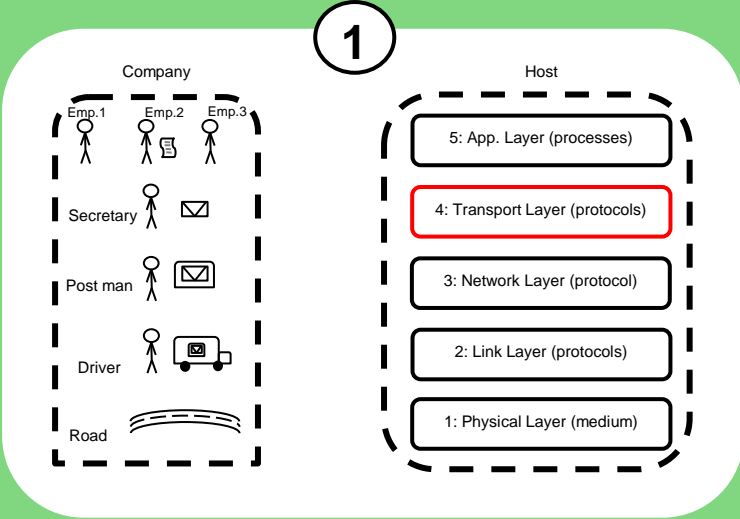

2

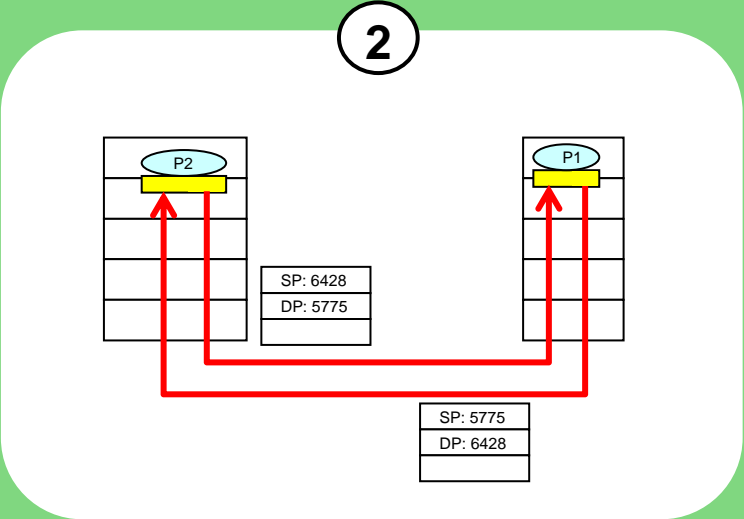

3

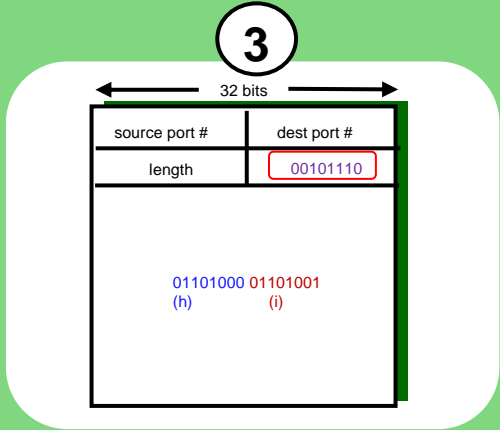

4

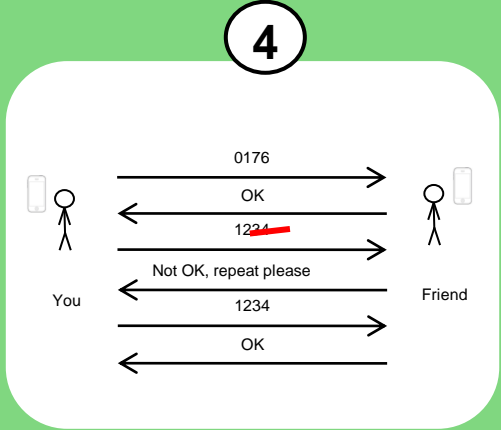

5

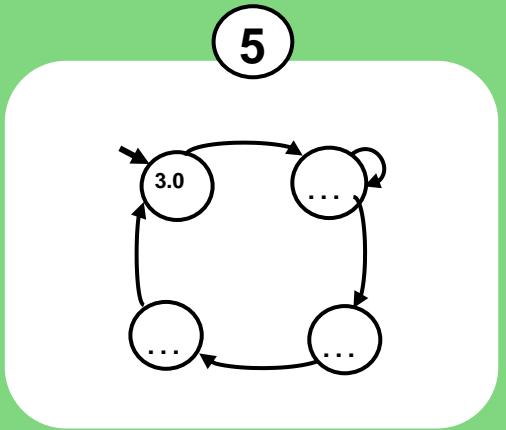

Chapter 3 outline

- 3.1 Transport-layer services
- 3.2 Multiplexing and demultiplexing
- 3.3 Connectionless transport: UDP
- **3.4 Principles of reliable data transfer**
- 3.5 Connection-oriented transport: TCP
 - segment structure
 - reliable data transfer
 - flow control
 - connection management
- 3.6 Principles of congestion control
- 3.7 TCP congestion control

Pipelining Protocols

Go-back-N: big picture:

- Sender can have up to N unacked packets in pipeline
- Rcvr only sends cumulative acks
 - Doesn't ack packet if there's a gap
- Sender has timer for oldest unacked packet
 - If timer expires, retransmit all unacked packets

Selective Repeat: big pic

- Sender can have up to N unacked packets in pipeline
- Rcvr acks individual packets
- Sender maintains timer for each unacked packet
 - When timer expires, retransmit only unack packet

Go-Back-N

Sender:

- k-bit seq # in pkt header
- “window” of up to N, consecutive unack’ed pkts allowed

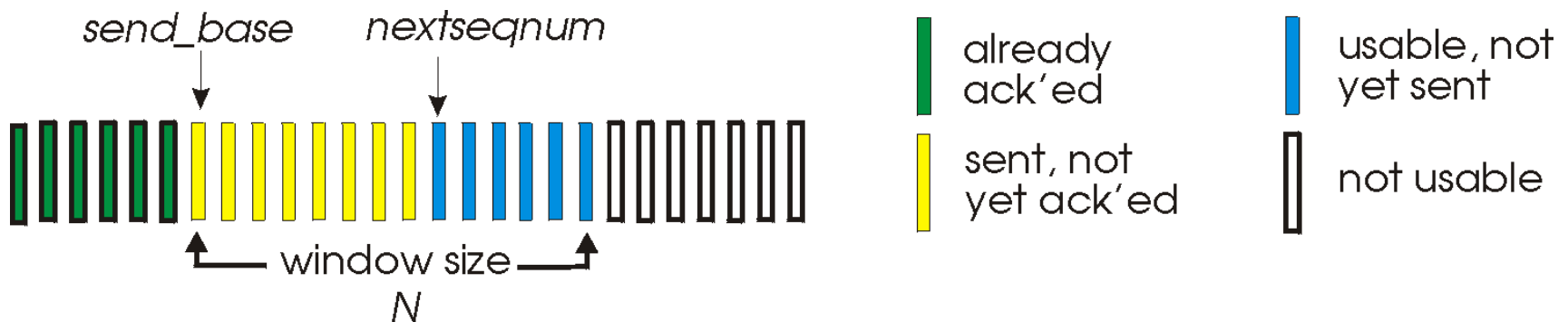

- ACK(n): ACKs all pkts up to, including seq # n - “cumulative ACK”
 - may receive duplicate ACKs (see receiver)
- timer for each in-flight pkt
- *timeout(n)*: retransmit pkt n and all higher seq # pkts in window

GBN in action

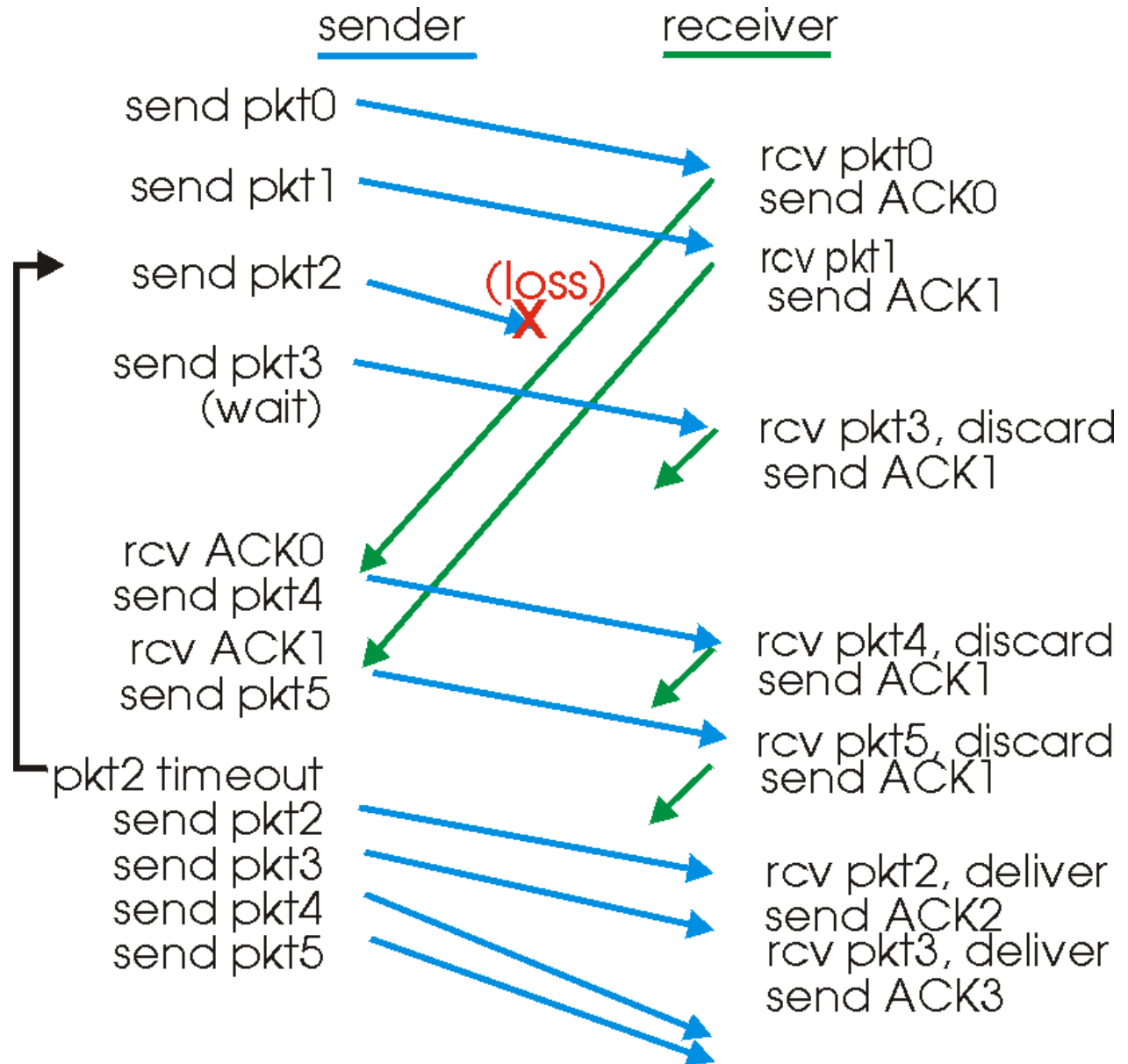

Go back n: sender extended FSM

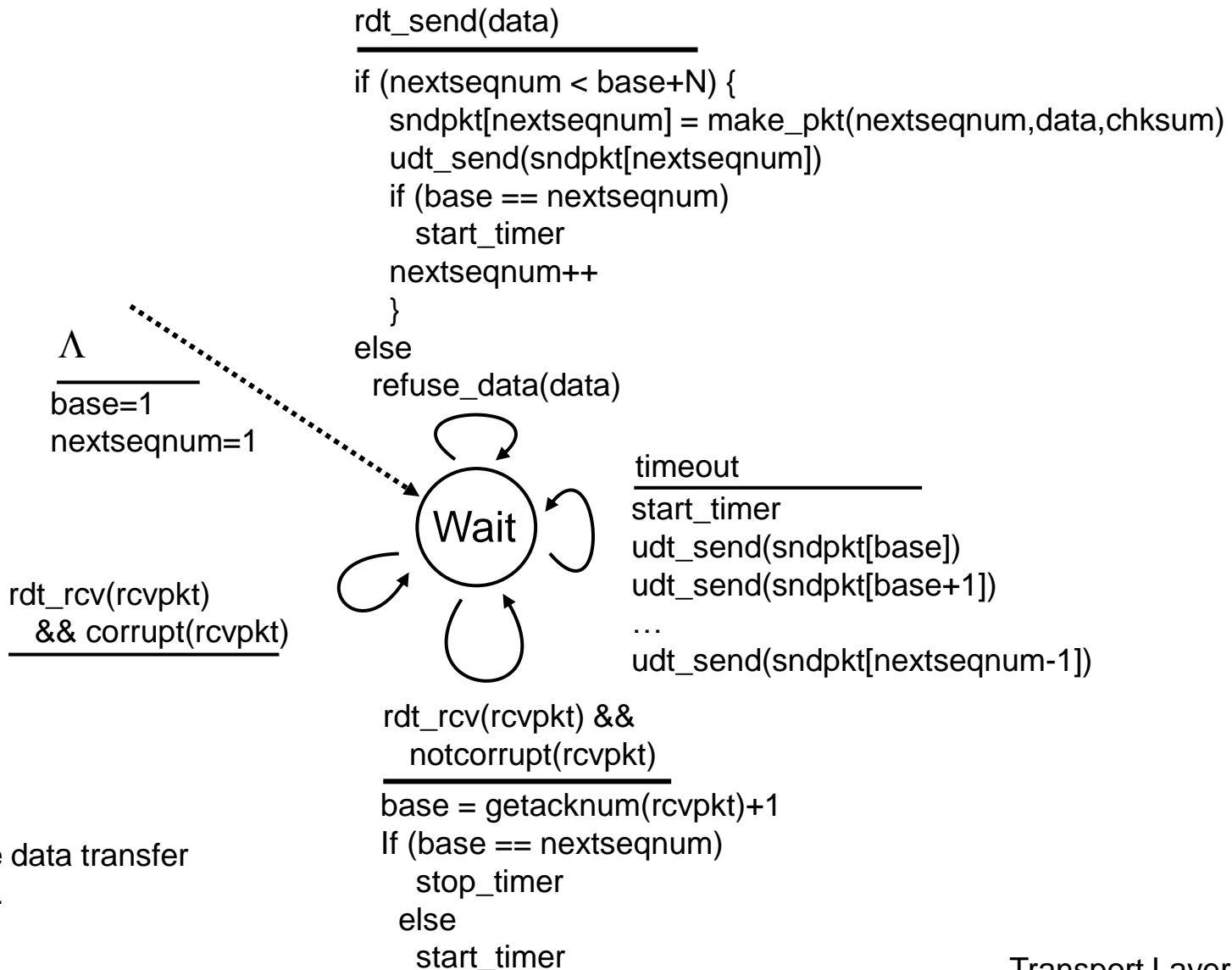

udt = unreliable data transfer
Rdt = reliable...

GBN: receiver extended FSM

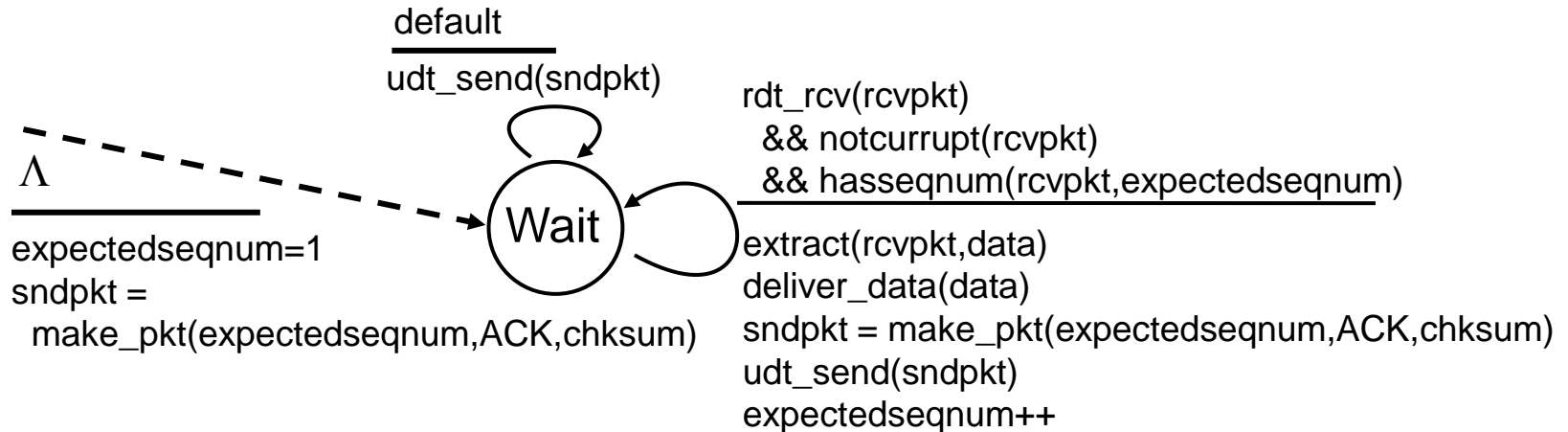

ACK-only: always send ACK for correctly-received pkt with highest *in-order* seq #

- may generate duplicate ACKs
- need only remember **expectedseqnum**
- out-of-order pkt:
 - discard (don't buffer) -> **no receiver buffering!**
 - Re-ACK pkt with highest in-order seq #

Selective Repeat

- receiver *individually* acknowledges all correctly received pkts
 - buffers pkts, as needed, for eventual in-order delivery to upper layer
- sender only resends pkts for which ACK not received
 - sender timer for each unACKed pkt
- sender window
 - N consecutive seq #'s
 - again limits seq #'s of sent, unACKed pkts

Selective repeat: sender, receiver windows

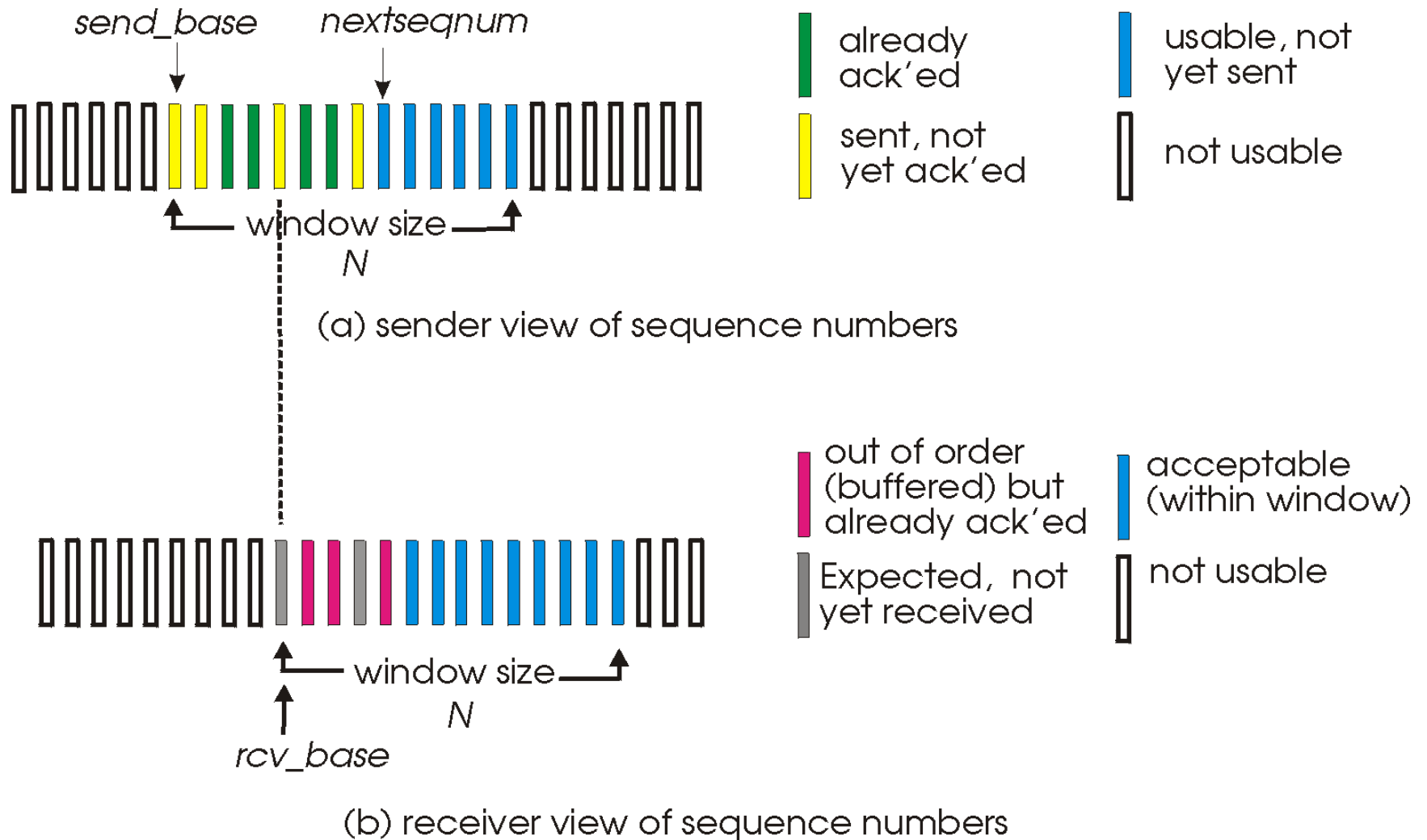

Selective repeat in action

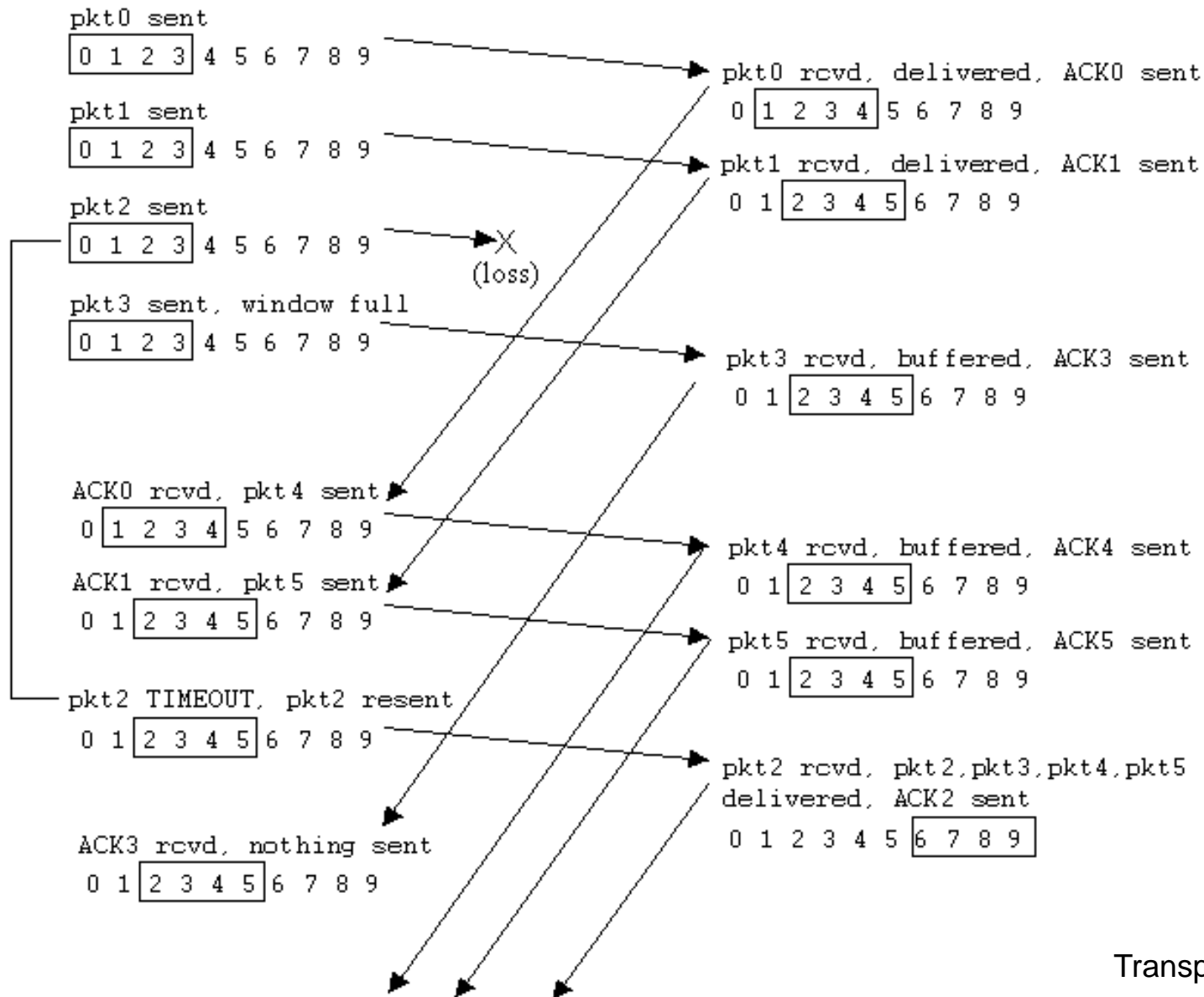

Selective repeat

sender

data from above :

- if next available seq # in window, send pkt

timeout(n):

- resend pkt n, restart timer

ACK(n) in [sendbase,sendbase+N]:

- mark pkt n as received
- if n smallest unACKed pkt, advance window base to next unACKed seq #

receiver

pkt n in [rcvbase, rcvbase+N-1]

- send ACK(n)
- out-of-order: buffer
- in-order: deliver (also deliver buffered, in-order pkts), advance window to next not-yet-received pkt

pkt n in [rcvbase-N,rcvbase-1]

- ACK(n)

otherwise:

- ignore

Selective repeat: dilemma

Example:

- seq #'s: 0, 1, 2, 3
 - window size=3
 - receiver sees no difference in two scenarios!
 - incorrectly passes duplicate data as new in (a)
- Notice:** Window size should be not too large, e.g. $\frac{1}{2}$ of sequence range.

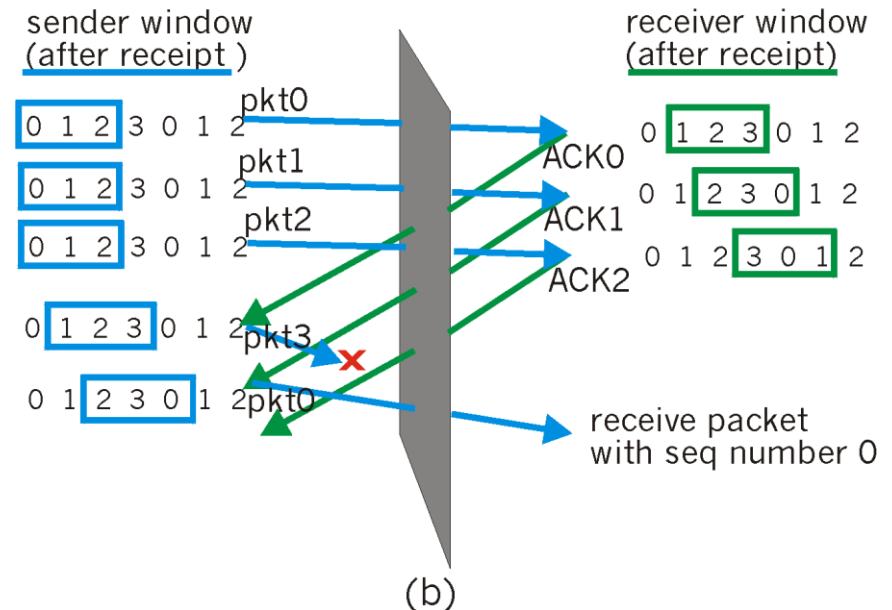
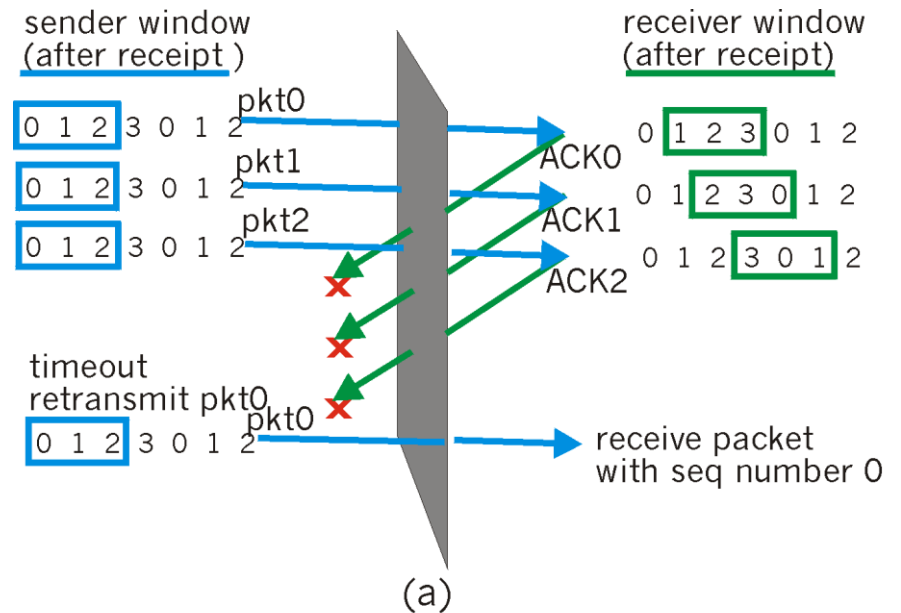

Chapter 3 outline

- 3.1 Transport-layer services
- 3.2 Multiplexing and demultiplexing
- 3.3 Connectionless transport: UDP
- 3.4 Principles of reliable data transfer
- 3.5 Connection-oriented transport: TCP
 - segment structure
 - reliable data transfer
 - flow control
 - connection management
- 3.6 Principles of congestion control
- 3.7 TCP congestion control

TCP: Overview

2581

RFCs: 793, 1122, 1323, 2018,

- **point-to-point:**
 - one sender, one receiver
 - **reliable, in-order *byte stream*:**
 - no “message boundaries”
 - **pipelined:**
 - TCP congestion and flow control set window size
 - ***send & receive buffers***
- **full duplex data:**
 - bi-directional data flow in same connection
 - MSS: maximum segment size
 - **connection-oriented:**
 - handshaking (exchange of control msgs) init's sender, receiver state before data exchange
 - **flow controlled:**
 - sender will not overwhelm receiver

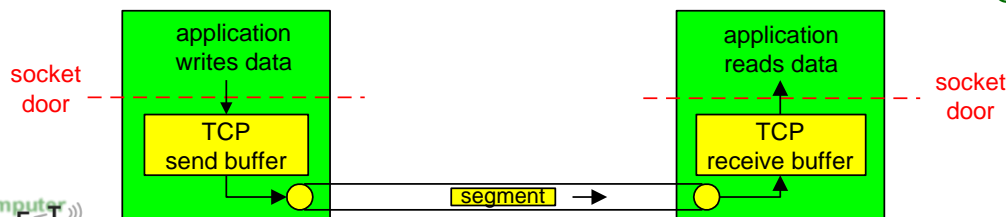

TCP segment structure

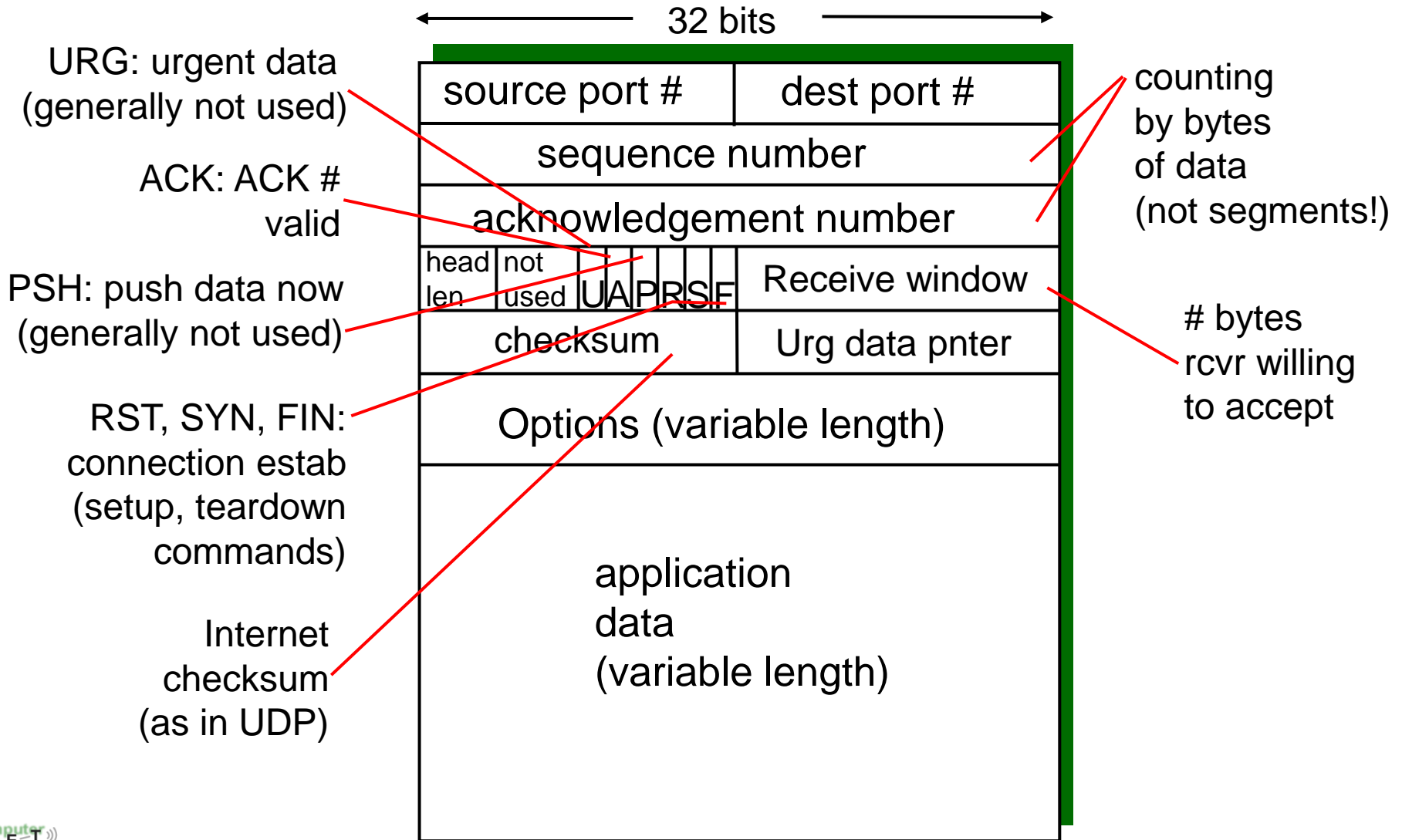

TCP seq. #'s and ACKs

Seq. #'s:

- byte stream
“number” of first byte in segment’s data

ACKs:

- seq # of next byte expected from other side
- cumulative ACK

Q: how receiver handles out-of-order segments

- A: TCP spec doesn’t say, - up to implementor

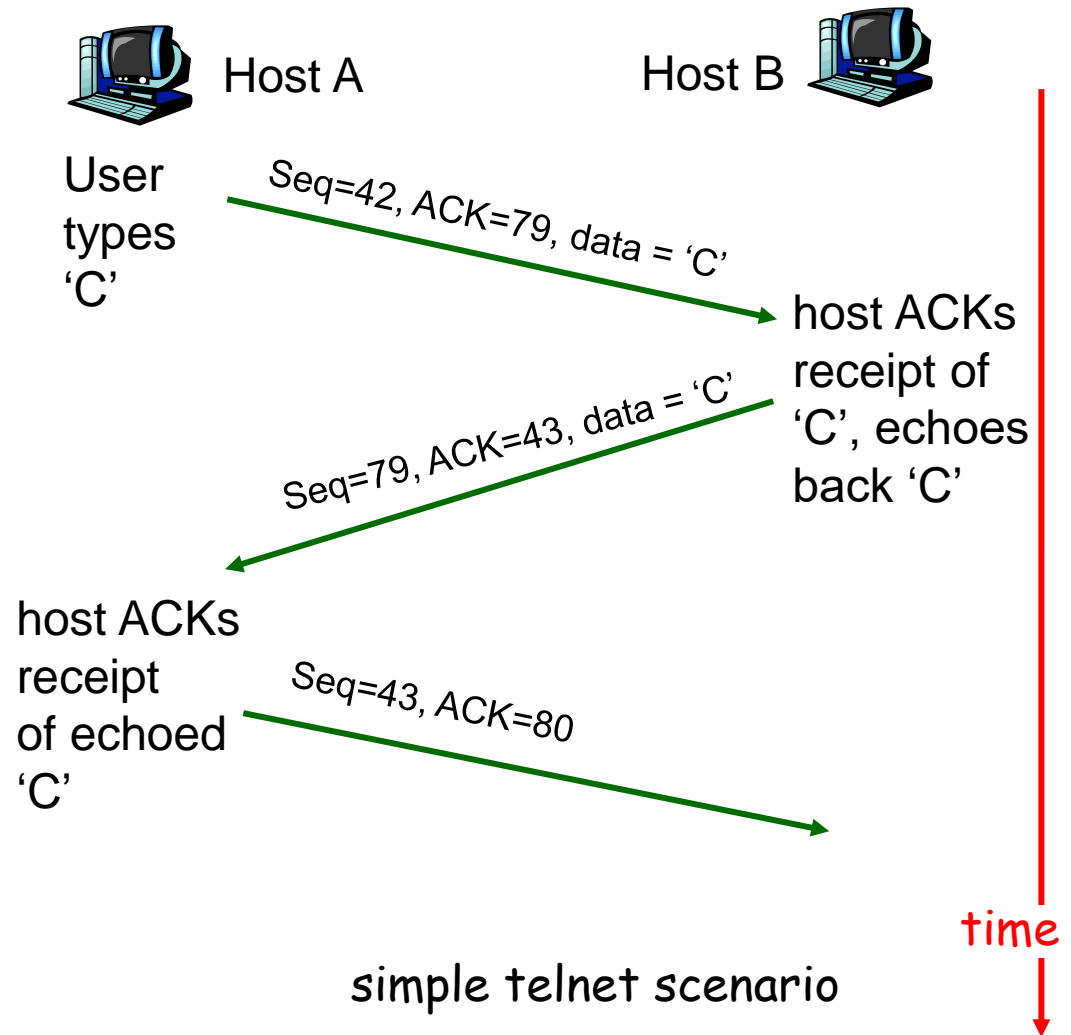

TCP Round Trip Time and Timeout

Q: how to set TCP timeout value?

- longer than RTT
 - but RTT varies
- too short: premature timeout
 - unnecessary retransmissions
- too long: slow reaction to segment loss

Q: how to estimate RTT?

- **SampleRTT**: measured time from segment transmission until ACK receipt
 - ignore retransmissions
- **SampleRTT** will vary, want estimated RTT “smoother”
 - average several recent measurements, not just current **SampleRTT**

TCP Round Trip Time and Timeout

$$\text{EstimatedRTT} = (1 - \alpha) * \text{EstimatedRTT} + \alpha * \text{SampleRTT}$$

- ❑ Exponential weighted moving average
- ❑ influence of past sample decreases exponentially fast
- ❑ typical value: $\alpha = 0.125$

Example RTT estimation:

RTT: gaia.cs.umass.edu to fantasia.eurecom.fr

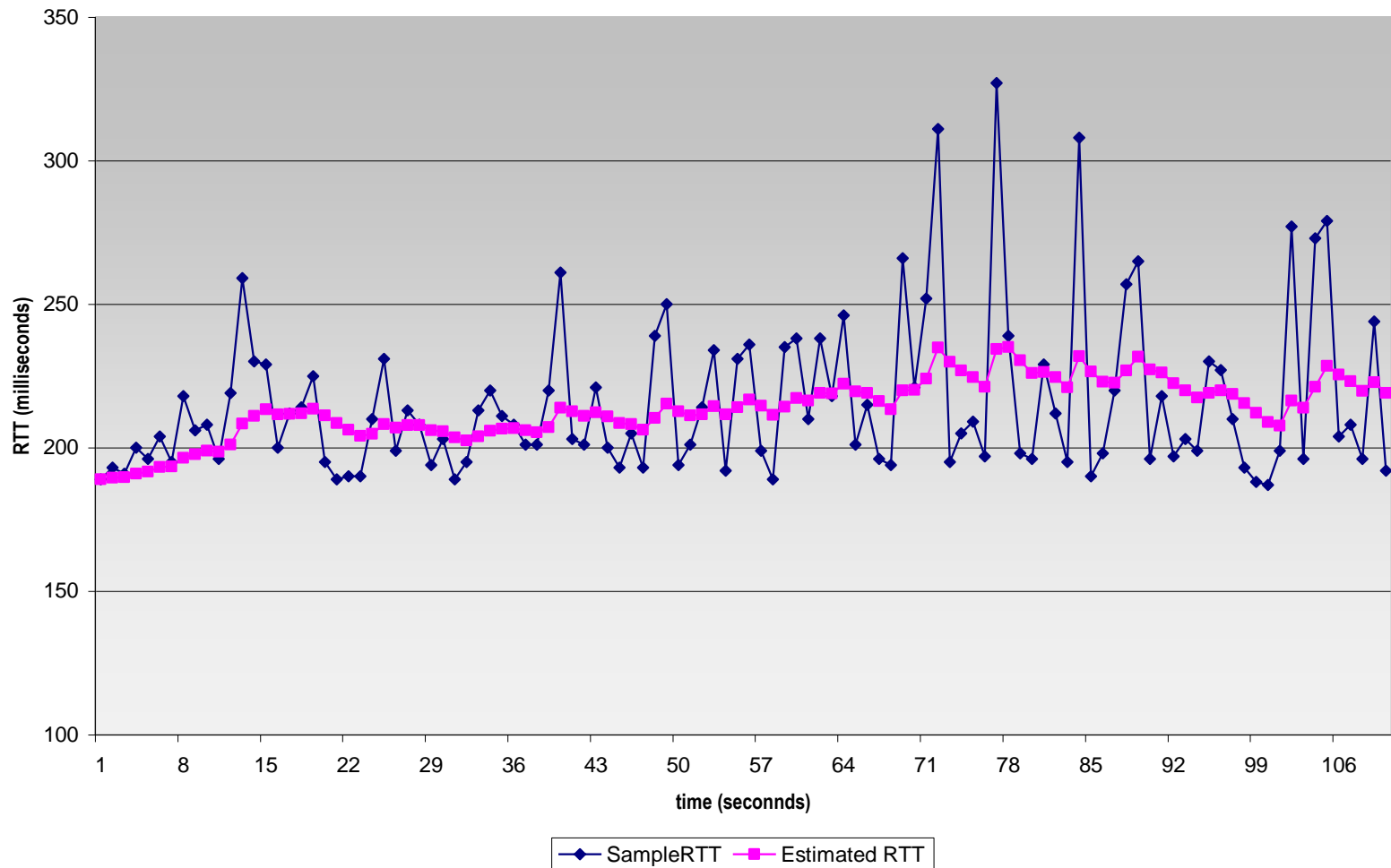

TCP Round Trip Time and Timeout

Setting the timeout

- **EstimatedRTT** plus “safety margin”
 - large variation in **EstimatedRTT** -> larger safety margin
- first estimate of how much **SampleRTT** deviates from **EstimatedRTT**:

$$\text{DevRTT} = (1-\beta)*\text{DevRTT} + \beta*|\text{SampleRTT}-\text{EstimatedRTT}|$$

(typically, $\beta = 0.25$)

Then set timeout interval:

$$\text{TimeoutInterval} = \text{EstimatedRTT} + 4*\text{DevRTT}$$

Chapter 3 outline

- 3.1 Transport-layer services
- 3.2 Multiplexing and demultiplexing
- 3.3 Connectionless transport: UDP
- 3.4 Principles of reliable data transfer
- 3.5 Connection-oriented transport: TCP
 - segment structure
 - **reliable data transfer**
 - flow control
 - connection management
- 3.6 Principles of congestion control
- 3.7 TCP congestion control

TCP reliable data transfer

- TCP creates rdt service on top of IP's unreliable service
- Pipelined segments
- Cumulative acks
- TCP uses single retransmission timer
- Retransmissions are triggered by:
 - timeout events
 - duplicate acks
- **Initially consider simplified TCP sender:**
 - ignore duplicate acks
 - ignore flow control, congestion control

TCP sender events:

data rcvd from app:

- Create segment with seq #
- seq # is byte-stream number of first data byte in segment
- start timer if not already running (think of timer as for oldest unacked segment)
- expiration interval: `TimeoutInterval`

timeout:

- retransmit segment that caused timeout
- restart timer

Ack rcvd:

- If acknowledges previously unacked segments
 - update what is known to be acked
 - start timer if there are outstanding segments

TCP: retransmission scenarios

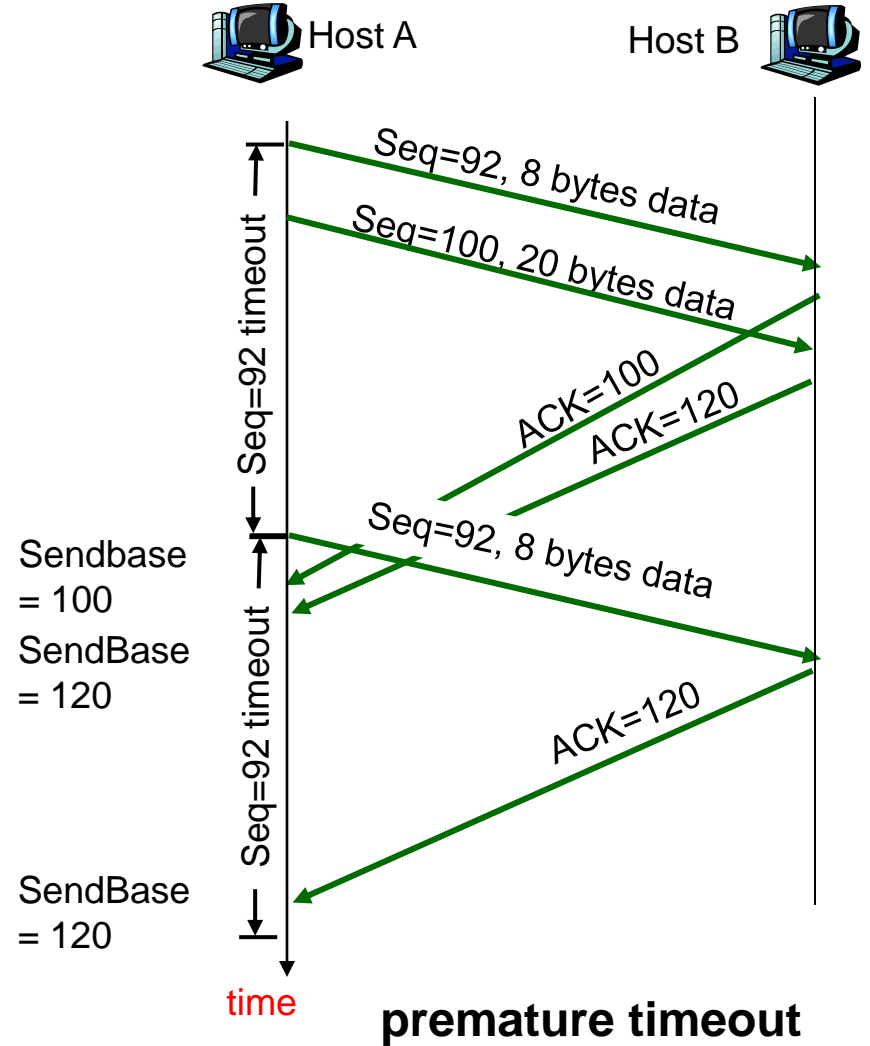
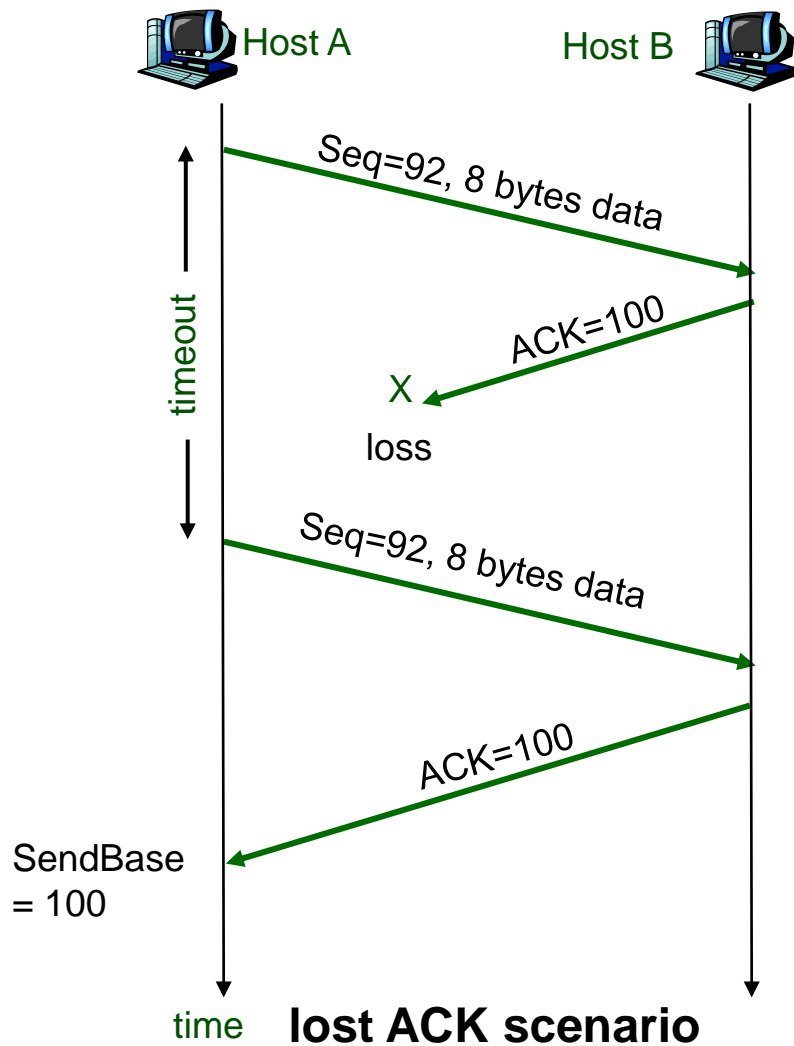

TCP retransmission scenarios (more)

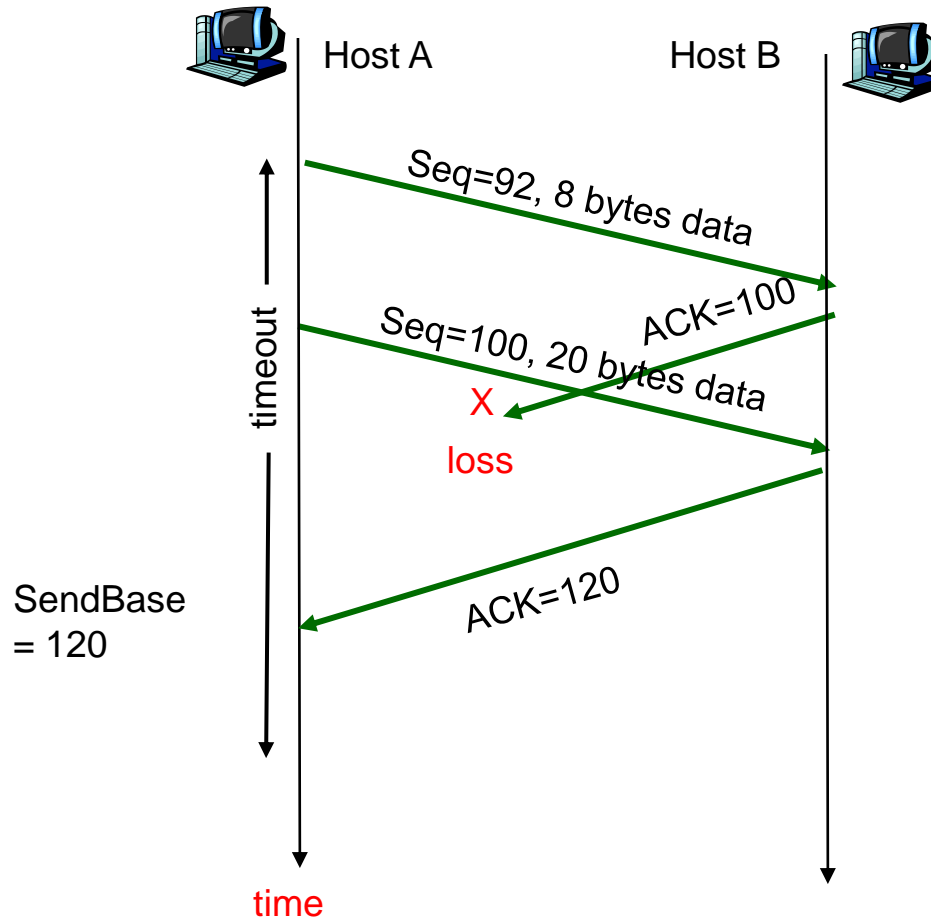

Cumulative ACK scenario

TCP ACK generation [RFC 1122, RFC 2581]

Event at Receiver

TCP Receiver action

Arrival of in-order segment with expected seq #. All data up to expected seq # already ACKed

Delayed ACK. Wait up to 500ms for next segment. If no next segment, send ACK

Arrival of in-order segment with expected seq #. One other segment has ACK pending

Immediately send single cumulative ACK, ACKing both in-order segments

Arrival of out-of-order segment higher-than-expected seq. # . Gap detected

Immediately send *duplicate ACK*, indicating seq. # of next expected byte

Arrival of segment that partially or completely fills gap

Immediate send ACK, provided that segment starts at lower end of gap

Fast Retransmit

- Time-out period often relatively long:
 - long delay before resending lost packet
- Detect lost segments via duplicate ACKs.
 - Sender often sends many segments back-to-back
 - If segment is lost, there will likely be many duplicate ACKs.
- If sender receives 3 ACKs for the same data, it supposes that segment after ACKed data was lost:
 - fast retransmit: resend segment before timer expires

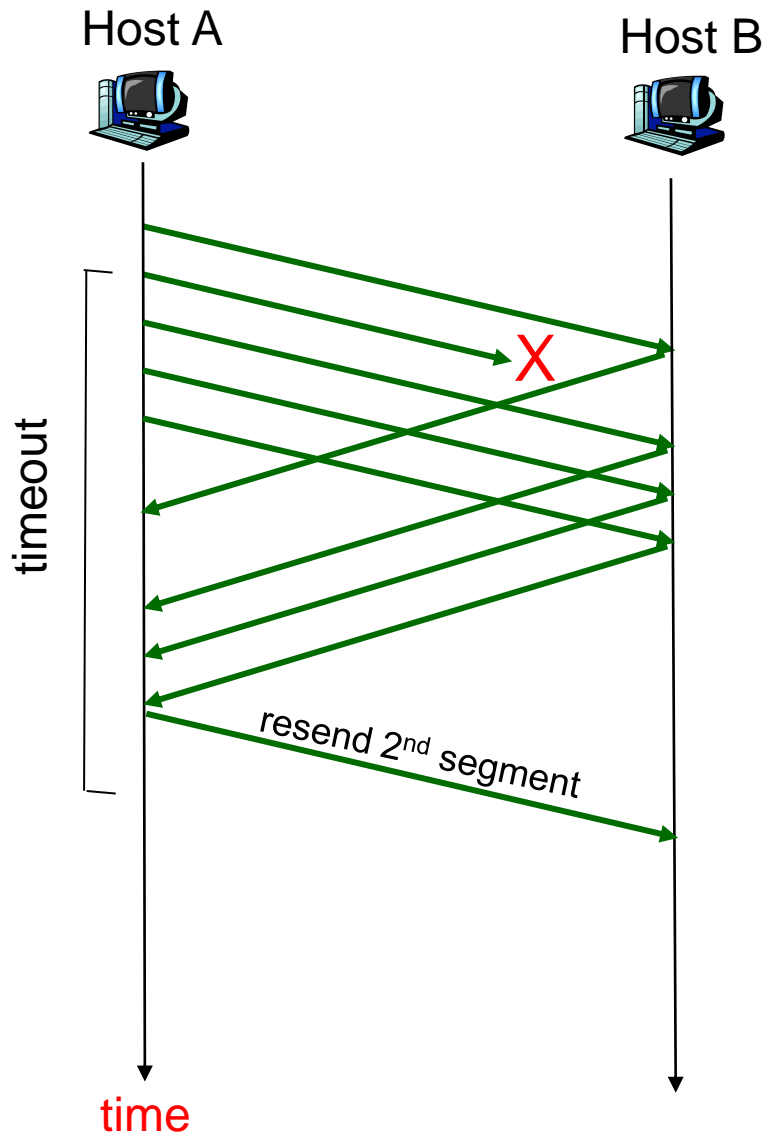

Figure 3.37 Resending a segment after triple duplicate ACK

Chapter 3 outline

- 3.1 Transport-layer services
- 3.2 Multiplexing and demultiplexing
- 3.3 Connectionless transport: UDP
- 3.4 Principles of reliable data transfer
- 3.5 Connection-oriented transport: TCP
 - segment structure
 - reliable data transfer
 - flow control
 - connection management
- 3.6 Principles of congestion control
- 3.7 TCP congestion control

Analogy: Flow Control

- Assumptions:
 - Secretary delivers mail at rate of 4 letters/h
 - Employee Bill processes mail at 1 letter/h.
 - Table has place for 10 letters, more will drop on floor.
- After half a day his table overflows, letters get lost.
- Sender needs to decrease sending rate.

time	Mail read	Mail on table
9:00	0	4
10:00	1	7
11:00	2	10
12:00	3	13 !

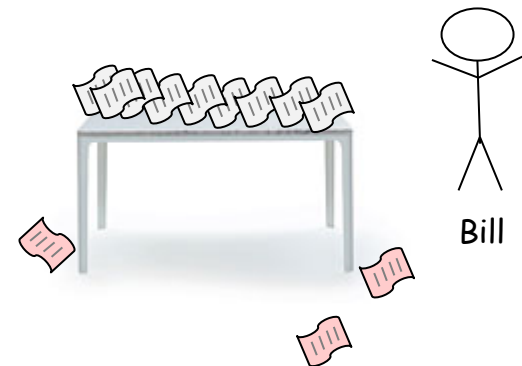

TCP Flow Control

- receive side of TCP connection has a receive buffer:

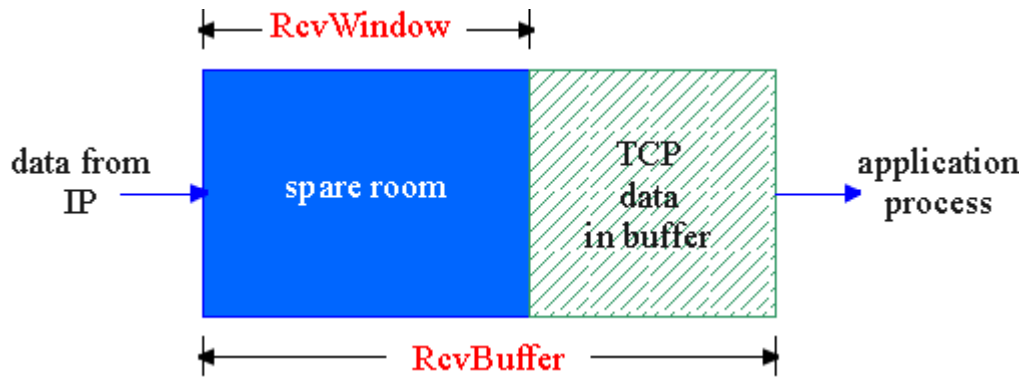

flow control

sender won't overflow receiver's buffer by transmitting too much, too fast

- speed-matching service: matching the send rate to the receiving app's drain rate

- app process may be slow at reading from buffer

TCP Flow control: how it works

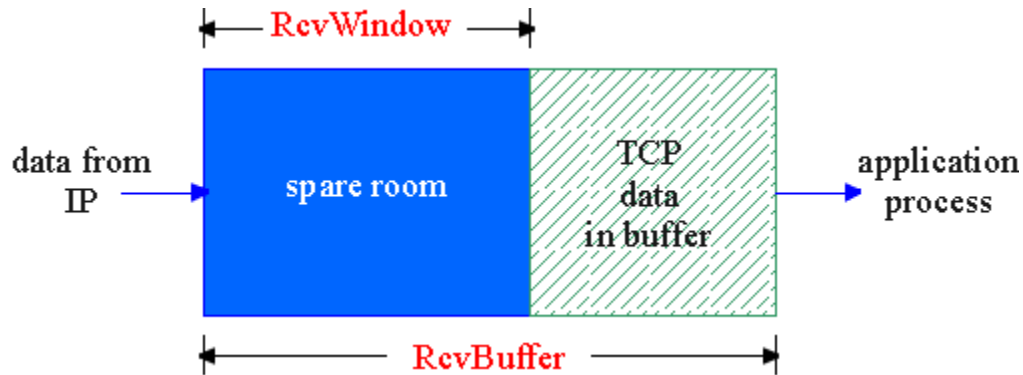

(Suppose TCP receiver discards out-of-order segments)

- spare room in buffer
- = RcvWindow
- = $\text{RcvBuffer} - [\text{LastByteRcvd} - \text{LastByteRead}]$

- Rcvr advertises spare room by including value of **RcvWindow** in segments
- Sender limits unACKed data to **RcvWindow**
 - guarantees receive buffer doesn't overflow

Chapter 3 outline

- 3.1 Transport-layer services
- 3.2 Multiplexing and demultiplexing
- 3.3 Connectionless transport: UDP
- 3.4 Principles of reliable data transfer
- 3.5 Connection-oriented transport: TCP
 - segment structure
 - reliable data transfer
 - flow control
 - **connection management**
- 3.6 Principles of congestion control
- 3.7 TCP congestion control

TCP Connection Management

Recall: TCP sender, receiver establish “connection” before exchanging data segments

- initialize TCP variables:
 - seq. #s
 - buffers, flow control info (e.g. `RcvWindow`)
- *client*: connection initiator

```
Socket clientSocket = new Socket("hostname", "port number");
```
- *server*: contacted by client

```
Socket connectionSocket = welcomeSocket.accept();
```

Three way handshake:

Step 1: client host sends TCP SYN segment to server

- specifies initial seq #
- no data

Step 2: server host receives SYN, replies with SYNACK segment

- server allocates buffers
- specifies server initial seq. #

Step 3: client receives SYNACK, replies with ACK segment, which may contain data

TCP Connection Management (cont.)

Closing a connection:

client closes socket:

```
clientSocket.close();
```

Step 1: client end system sends TCP FIN control segment to server

Step 2: server receives FIN, replies with ACK. Closes connection, sends FIN.

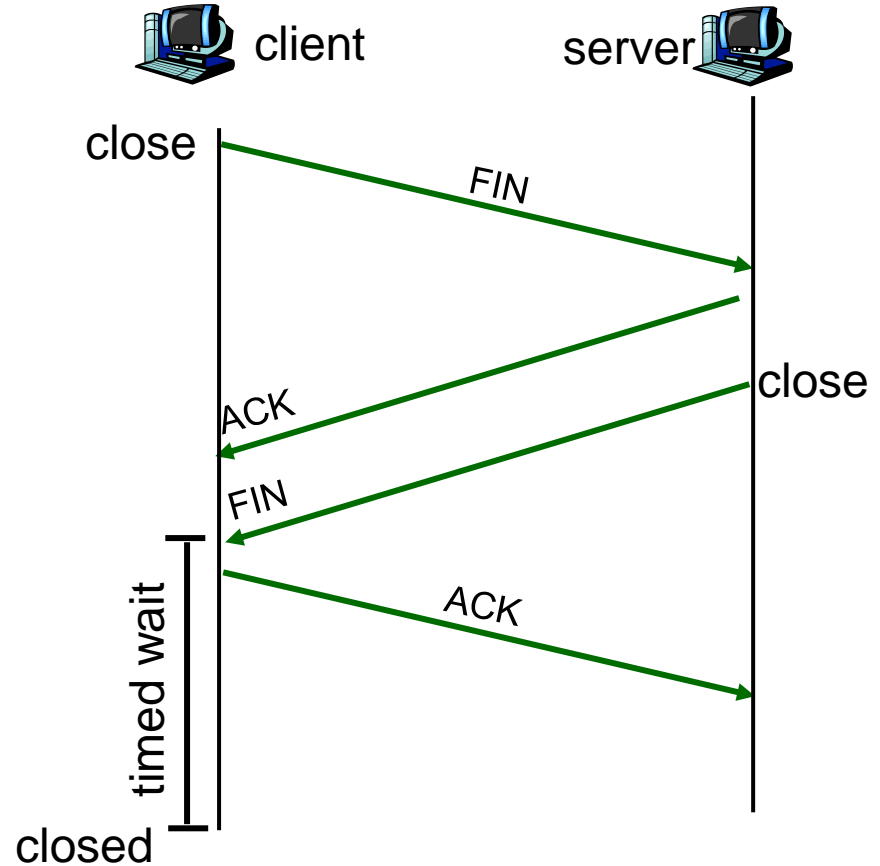

TCP Connection Management (cont.)

Step 3: client receives FIN, replies with ACK.

- Enters “timed wait” - will respond with ACK to received FINs

Step 4: server, receives ACK. Connection closed.

Note: with small modification, can handle simultaneous FINs.

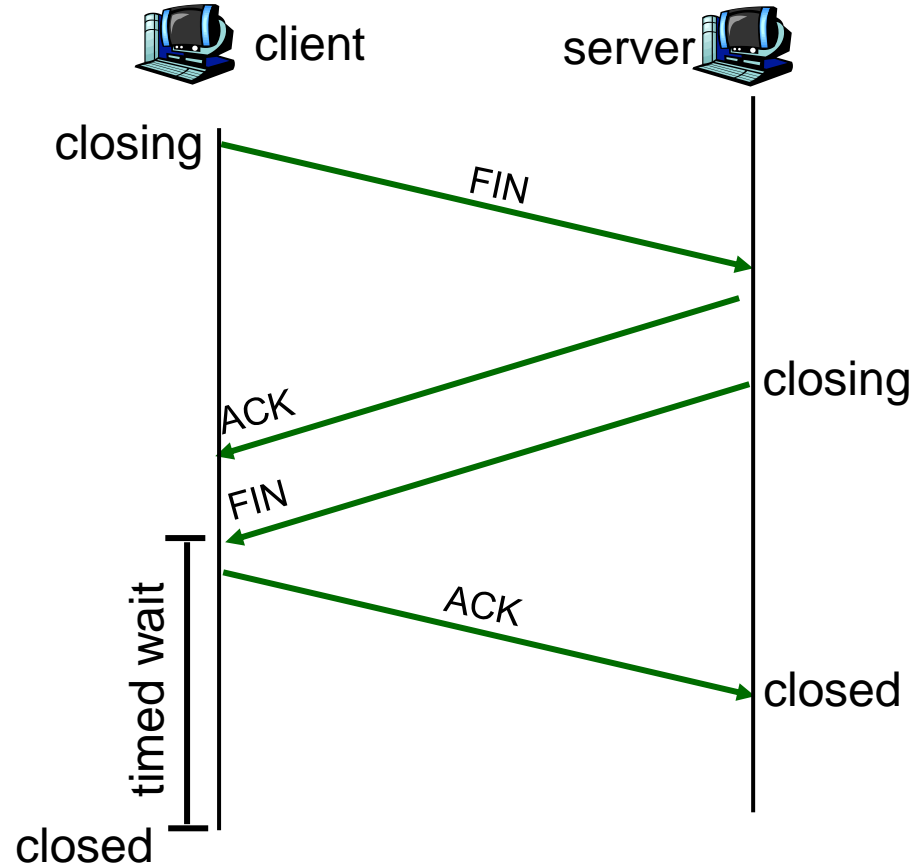

TCP Connection Management (cont)

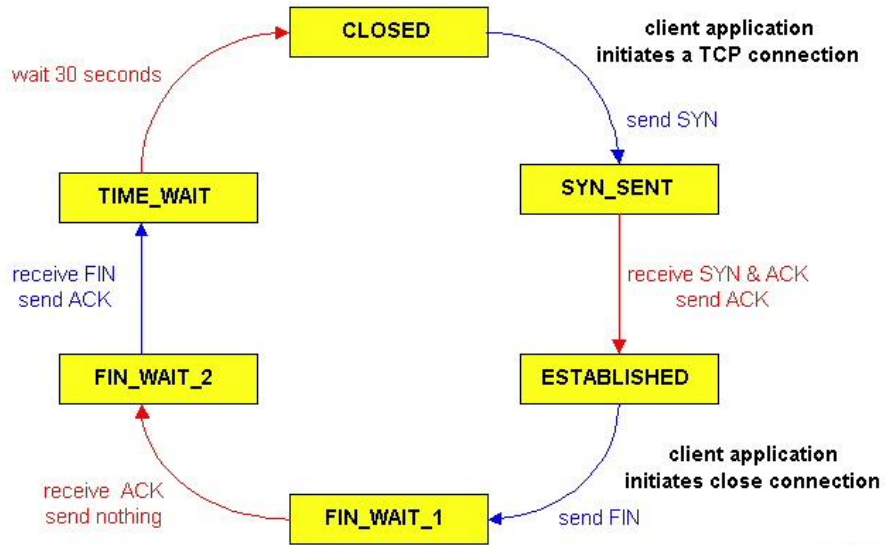

TCP client lifecycle

TCP server lifecycle

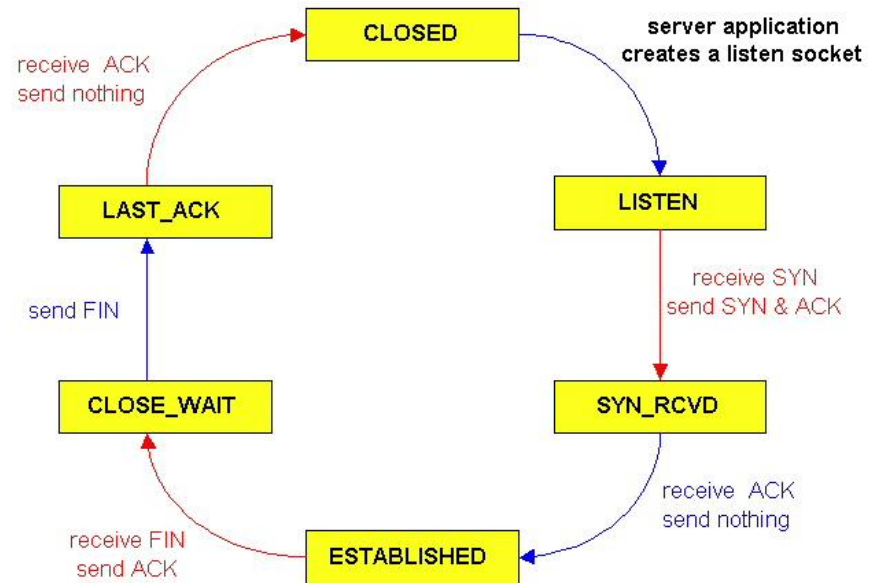

Chapter 3 outline

- 3.1 Transport-layer services
- 3.2 Multiplexing and demultiplexing
- 3.3 Connectionless transport: UDP
- 3.4 Principles of reliable data transfer
- 3.5 Connection-oriented transport: TCP
 - segment structure
 - reliable data transfer
 - flow control
 - connection management
- **3.6 Principles of congestion control**
- 3.7 TCP congestion control

Principles of Congestion Control

Congestion:

- informally: “too many sources sending too much data too fast for *network* to handle”
- different from flow control! (overflow at receiver v.s. overflow on path routers)
- manifestations:
 - lost packets (buffer overflow at routers)
 - long delays (queueing in router buffers)
- a top-10 problem!

Causes/costs of congestion: scenario 1

- two senders, two receivers
- one router, infinite buffers
- no retransmission

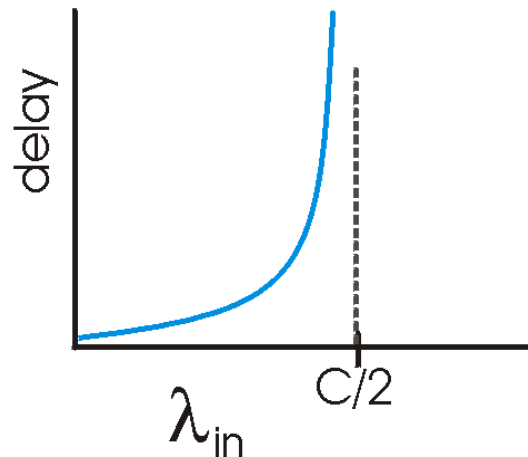
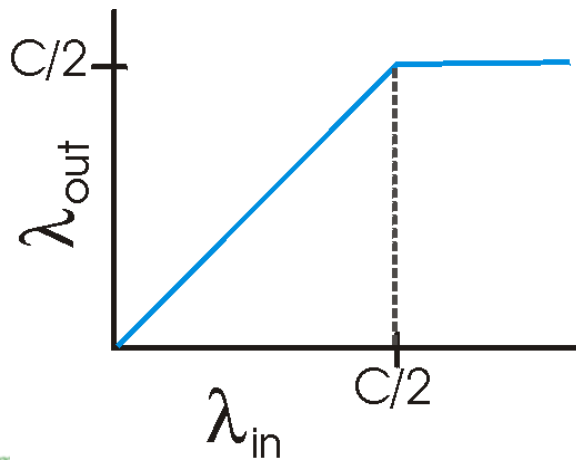
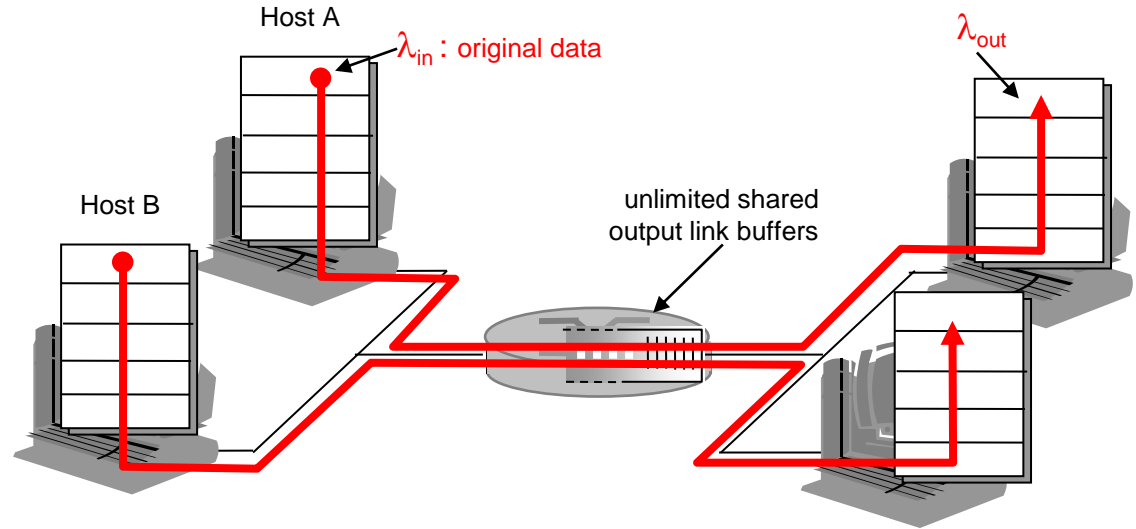

- large delays when congested
- maximum achievable throughput

Causes/costs of congestion: scenario 2

- one router, *finite* buffers
- sender retransmission of lost packet

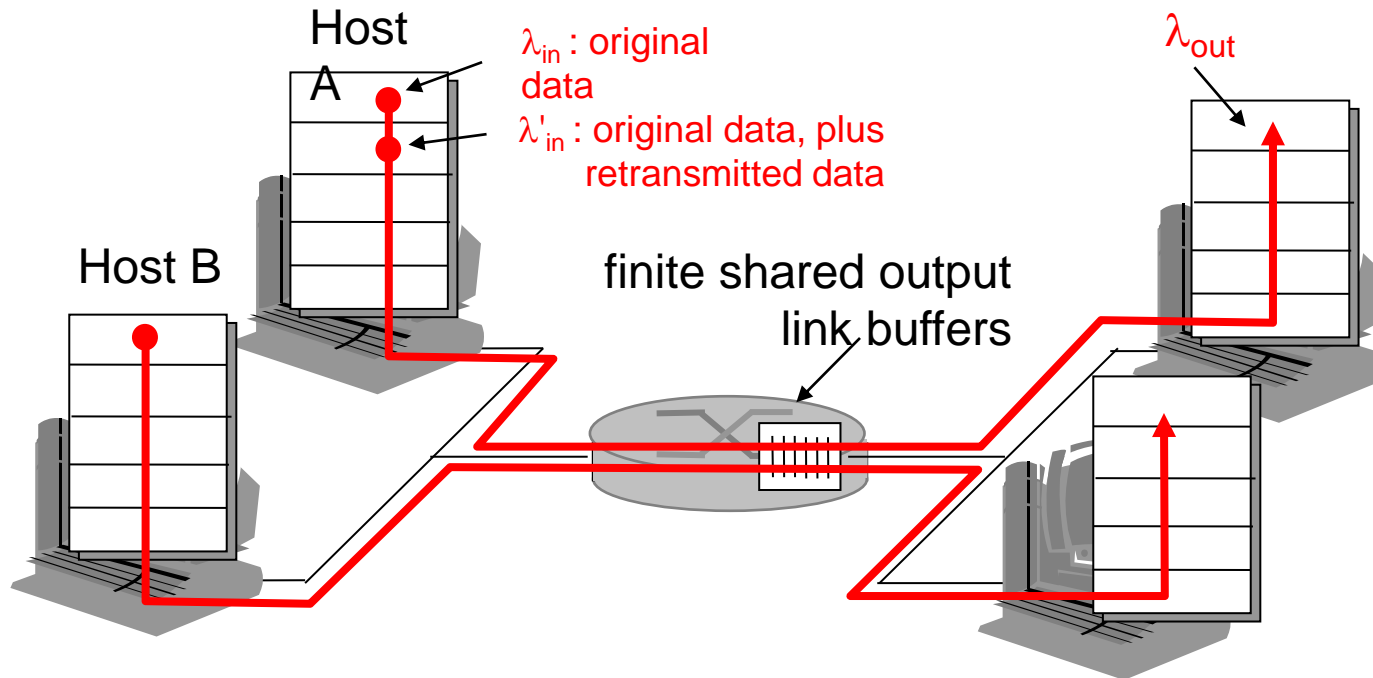

Causes/costs of congestion: scenario 2

- always: $\lambda_{in} = \lambda_{out}$ (goodput)
- “perfect” retransmission only when loss: $\lambda'_{in} > \lambda_{out}$
- retransmission of delayed (not lost) packet makes λ'_{in} larger (than perfect case) for same λ_{out}

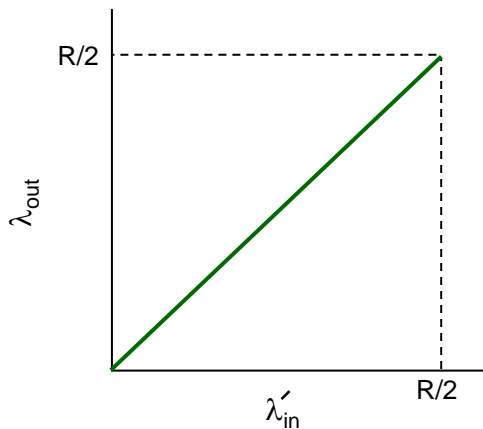

a.

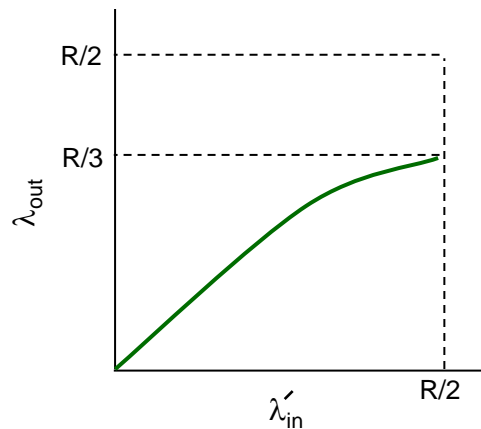

b.

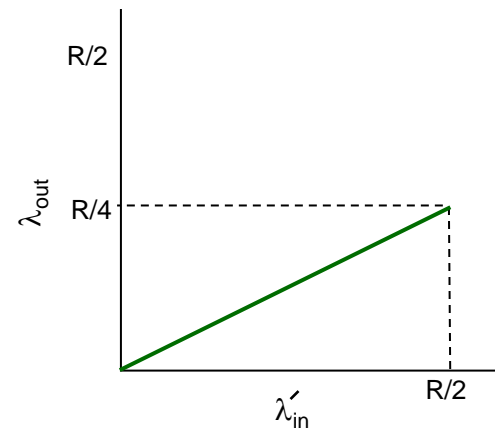

c.

“costs” of congestion:

- ❑ more work (retrans) for given “goodput”
- ❑ unneeded retransmissions: link carries multiple copies of pkt

Causes/costs of congestion: scenario 3

- four senders
- multihop paths
- timeout/retransmit

Q: what happens as λ_{in} and λ'_{in} increase ?

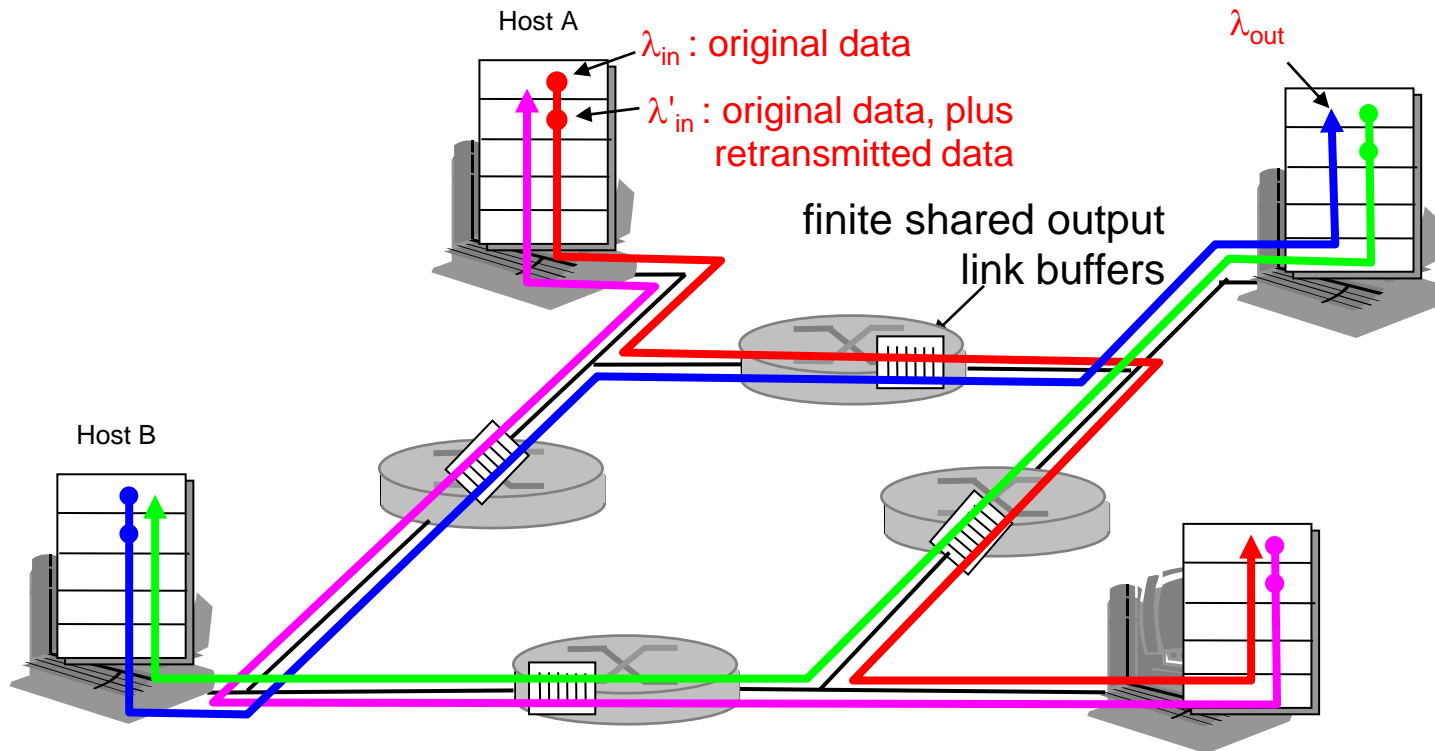

Causes/costs of congestion: scenario 3

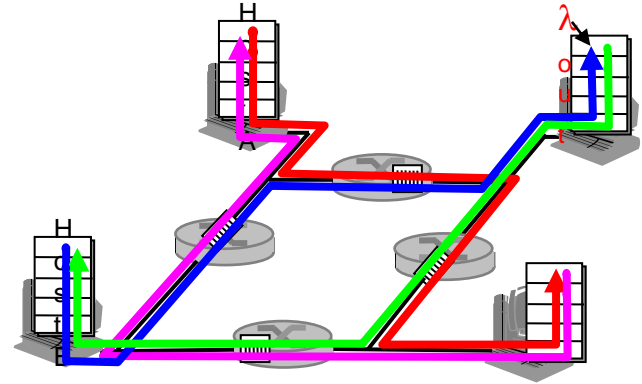
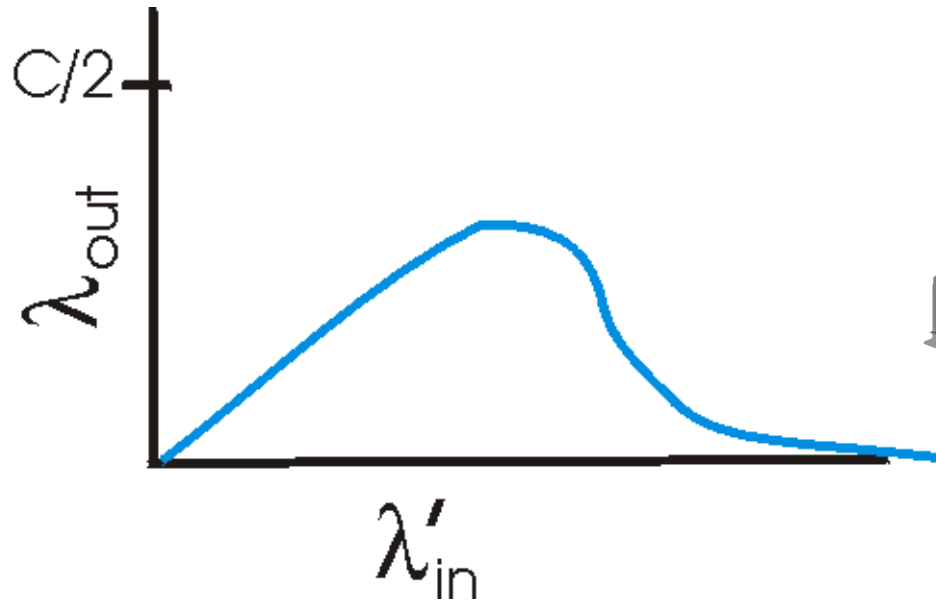

Another “cost” of congestion:

- when packet dropped, any “upstream transmission capacity used for that packet was wasted!

Approaches towards congestion control

Two broad approaches towards congestion control:

End-end congestion control:

- no explicit feedback from network
- congestion inferred from end-system observed loss, delay
- approach taken by TCP

Network-assisted congestion control:

- routers provide feedback to end systems
 - single bit indicating congestion (SNA, DECbit, TCP/IP ECN, ATM)
 - explicit rate sender should send at

Case study: ATM ABR congestion control

ABR: available bit rate:

- “elastic service”
- if sender’s path “underloaded”:
 - sender should use available bandwidth
- if sender’s path congested:
 - sender throttled to minimum guaranteed rate

RM (resource management) cells:

- sent by sender, interspersed with data cells
- bits in RM cell set by switches (“*network-assisted*”)
 - **NI bit**: no increase in rate (mild congestion)
 - **CI bit**: congestion indication
- RM cells returned to sender by receiver, with bits intact

Case study: ATM ABR congestion control

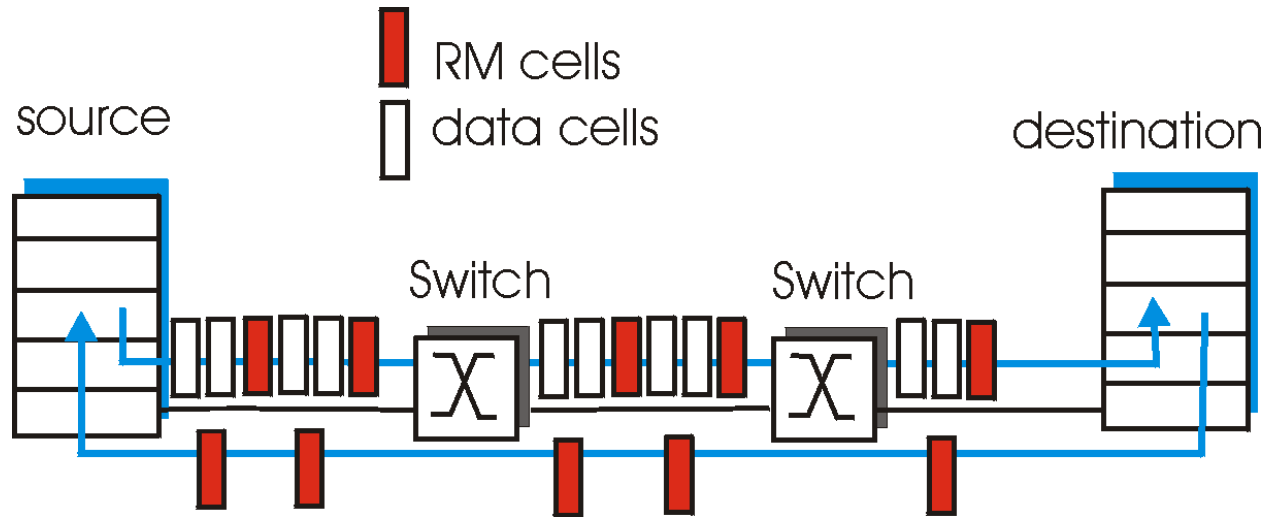

- two-byte ER (explicit rate) field in RM cell
 - congested switch may lower ER value in cell
 - sender' send rate thus maximum supportable rate on path
- EFCI bit in data cells: set to 1 in congested switch
 - if data cell preceding RM cell has EFCI set, sender sets CI bit in returned RM cell

Chapter 3 outline

- 3.1 Transport-layer services
- 3.2 Multiplexing and demultiplexing
- 3.3 Connectionless transport: UDP
- 3.4 Principles of reliable data transfer
- 3.5 Connection-oriented transport: TCP
 - segment structure
 - reliable data transfer
 - flow control
 - connection management
- 3.6 Principles of congestion control
- **3.7 TCP congestion control**

TCP congestion control: additive increase, multiplicative decrease

- *Approach*: increase transmission rate (window size), probing for usable bandwidth, until loss occurs
 - *additive increase*: increase **CongWin** by 1 MSS every RTT until loss detected
 - *multiplicative decrease*: cut **CongWin** in half after loss

Saw tooth behavior: probing for bandwidth

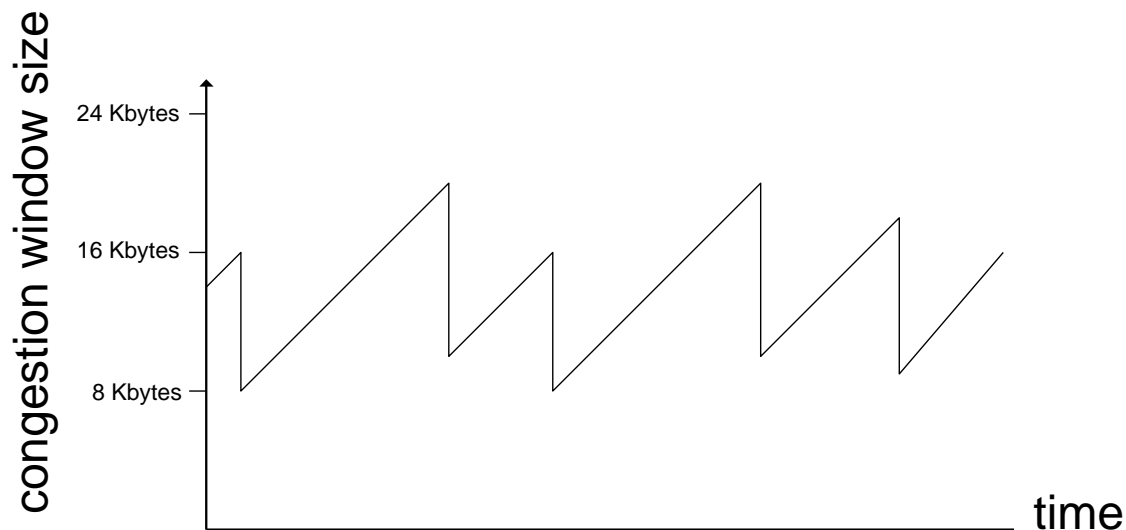

TCP Congestion Control: details

- sender limits transmission:

$$\text{LastByteSent} - \text{LastByteAked} \leq \text{CongWin}$$

- Roughly,

$$\text{rate} = \frac{\text{CongWin}}{\text{RTT}} \text{ Bytes/sec}$$

- **CongWin** is dynamic, function of perceived network congestion

How does sender perceive congestion?

- loss event = timeout or 3 duplicate acks
- TCP sender reduces rate (**CongWin**) after loss event

three mechanisms:

- AIMD
- slow start
- conservative after timeout events

TCP Slow Start

- When connection begins, **CongWin = 1 MSS**
 - Example: MSS = 500 bytes & RTT = 1000 msec (1sec)
 - initial rate = 500 bytes/s
- available bandwidth may be \gg MSS/RTT
 - desirable to quickly ramp up to respectable rate
- When connection begins, increase rate exponentially fast until first loss event

TCP Slow Start (more)

- When connection begins, increase rate exponentially until first loss event:
 - double **CongWin** every RTT
 - done by incrementing **CongWin** for every ACK received
- Summary: initial rate is slow but ramps up exponentially fast

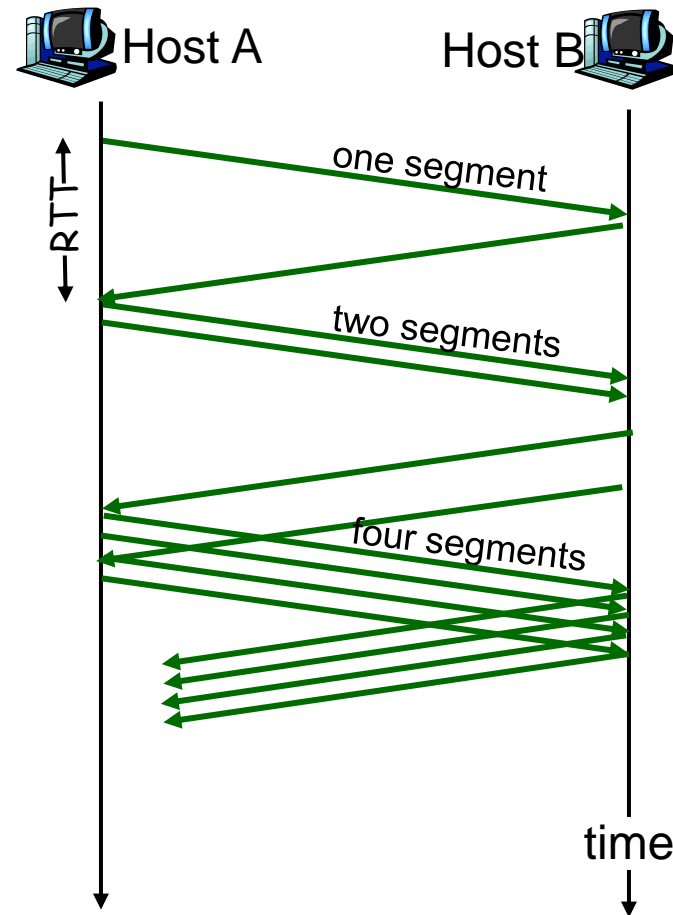

Refinement: inferring loss

- After 3 dup ACKs:
 - **CongWin** is cut in half
 - window then grows linearly
- But after timeout event:
 - **CongWin** instead set to 1 MSS;
 - window then grows exponentially
 - to a threshold, then grows linearly

Philosophy:

- ❑ 3 dup ACKs indicates network capable of delivering some segments
- ❑ timeout indicates a “more alarming” congestion scenario

Refinement

Q: When should the exponential increase switch to linear?

A: When **CongWin** gets to 1/2 of its value before timeout.

Implementation:

- Variable Threshold
- At loss event, Threshold is set to 1/2 of CongWin just before loss event

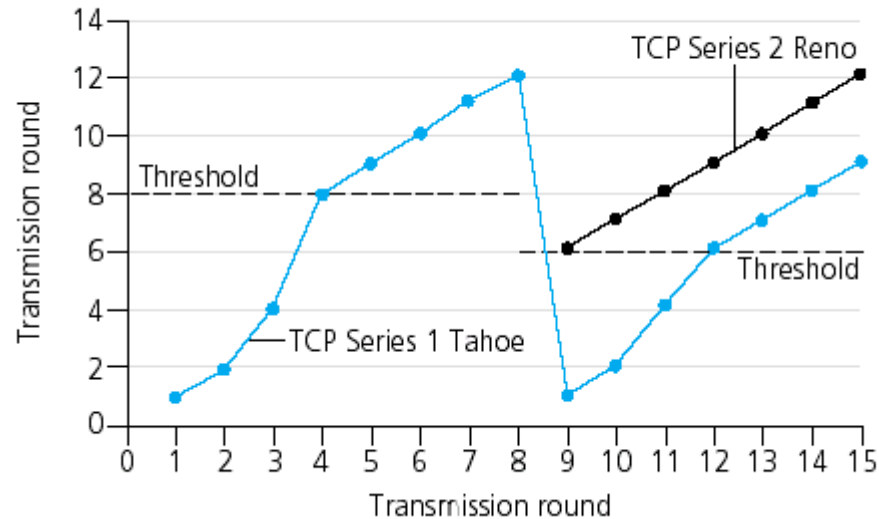

Summary: TCP Congestion Control

- When **CongWin** is below **Threshold**, sender in **slow-start** phase, window grows exponentially.
- When **CongWin** is above **Threshold**, sender is in **congestion-avoidance** phase, window grows linearly.
- When a **triple duplicate ACK** occurs, **Threshold** set to **CongWin/2** and **CongWin** set to **Threshold**.
- When **timeout** occurs, **Threshold** set to **CongWin/2** and **CongWin** is set to 1 MSS.

TCP sender congestion control

State	Event	TCP Sender Action	Commentary
Slow Start (SS)	ACK receipt for previously unacked data	CongWin = CongWin + MSS, If (CongWin > Threshold) set state to "Congestion Avoidance"	Resulting in a doubling of CongWin every RTT
Congestion Avoidance (CA)	ACK receipt for previously unacked data	CongWin = CongWin + MSS * (MSS / CongWin)	Additive increase, resulting in increase of CongWin by 1 MSS every RTT
SS or CA	Loss event detected by triple duplicate ACK	Threshold = CongWin / 2, CongWin = Threshold, Set state to "Congestion Avoidance"	Fast recovery, implementing multiplicative decrease. CongWin will not drop below 1 MSS.
SS or CA	Timeout	Threshold = CongWin / 2, CongWin = 1 MSS, Set state to "Slow Start"	Enter slow start
SS or CA	Duplicate ACK	Increment duplicate ACK count for segment being acked	CongWin and Threshold not changed

TCP throughput

- What's the average throughput of TCP as a function of window size and RTT?
 - Ignore slow start
- Let W be the window size when loss occurs.
- When window is W , throughput is W/RTT
- Just after loss, window drops to $W/2$, throughput to $W/2RTT$.
- Average throughput: $.75 W/RTT$

Chapter 3: Summary

- principles behind transport layer services:
 - multiplexing, demultiplexing
 - reliable data transfer
 - flow control
 - congestion control
- instantiation and implementation in the Internet
 - UDP
 - TCP

Next:

- Network Layer

Thank you

Any questions?