

Exercise 8

December 19th, 2013

TCP congestion control

- N=200, RTT=200ms, MSS=1000 bytes, sender just sent a complete window!
 - a) Assuming no loss, what is the throughput (in terms of MSS and RTT and in terms of Megabit/s) of this message exchange?

$$\text{throughput} = \frac{\text{segments} \cdot \text{MSS}}{\text{RTT}} = \frac{200 \cdot 8000 \text{Bit}}{0.2 \text{s}} = 8000000 \frac{\text{Bit}}{\text{s}} = 8 \frac{\text{MBit}}{\text{s}}$$

TCP congestion control cont'd

- b) Suppose TCP is in its congestion avoidance phase. Assuming no loss, what is the window size (in terms of segment) after the $N = 200$ segments are acknowledged?
- From the lecture:
 - When **CongWin** is above **Threshold**, sender is in **congestion-avoidance** phase, window grows linearly.
 - **CongWin** is in units of MSS

TCP sender congestion control

State	Event	TCP Sender Action	Commentary
Slow Start (SS)	ACK receipt for previously unacked data	CongWin = CongWin + MSS, If (CongWin > Threshold) set state to "Congestion Avoidance"	Resulting in a doubling of CongWin every RTT
Congestion Avoidance (CA)	ACK receipt for previously unacked data	CongWin = CongWin + MSS * (MSS / CongWin)	Additive increase, resulting in increase of CongWin by 1 MSS every RTT
SS or CA	Loss event detected by triple duplicate ACK	Threshold = CongWin / 2, CongWin = Threshold, Set state to "Congestion Avoidance"	Fast recovery, implementing multiplicative decrease. CongWin will not drop below 1 MSS.
SS or CA	Timeout	Threshold = CongWin / 2, CongWin = 1 MSS, Set state to "Slow Start"	Enter slow start
SS or CA	Duplicate ACK	Increment duplicate ACK count for segment being acked	CongWin and Threshold not changed

TCP congestion control cont'd

- b) Suppose TCP is in its congestion avoidance phase. Assuming no loss, what is the window size (in terms of segment) after the $N = 200$ segments are acknowledged? (CongWin = CW)

- in one RTT:
$$CW = CW + MSS \cdot \left(\frac{MSS}{CW} \right)$$

- Each ack increases the CW by MSS/CW , which is $8000\text{Bit}/200=40\text{Bit}$. As 200 acks arrive, the window is increased by 8000Bit which is exactly 1MSS, therefore $CW=200+1$! Note $CW = 200+1$ MSS!

TCP-Reno and Tahoe

- What is the difference between the two congestion control algorithms TCP-Tahoe and TCP-Reno?

- Difference in handling time-outs and triple duplicate acks!

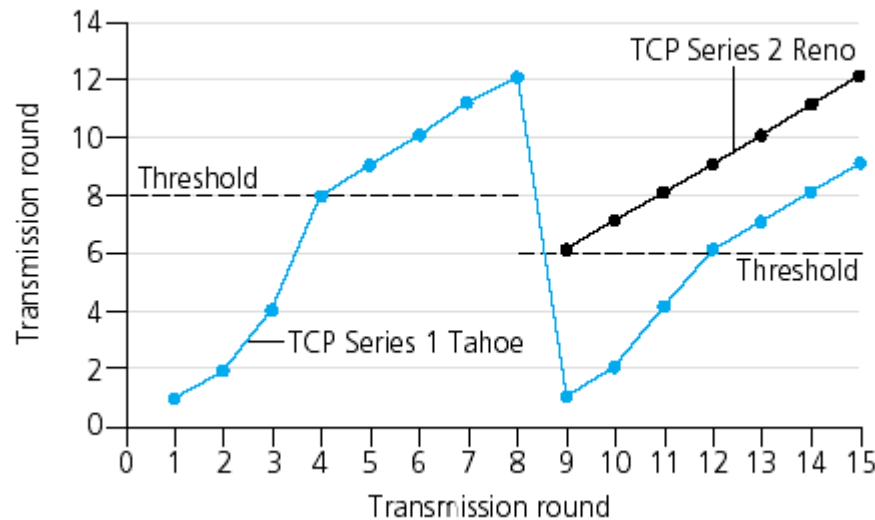

- Tahoe always down to 1MSS, Reno distinguishes: 3 duplicate ACKs-> go down to 50% then CA, timeout -> go down to 1MSS

Selective Repeat

- Please explain the selective repeat dilemma and name a solution to prevent its occurrence.
- Dilemma occurs on a limited sequence range and large window size. Solution: Window size should be maximally half of the sequence range!

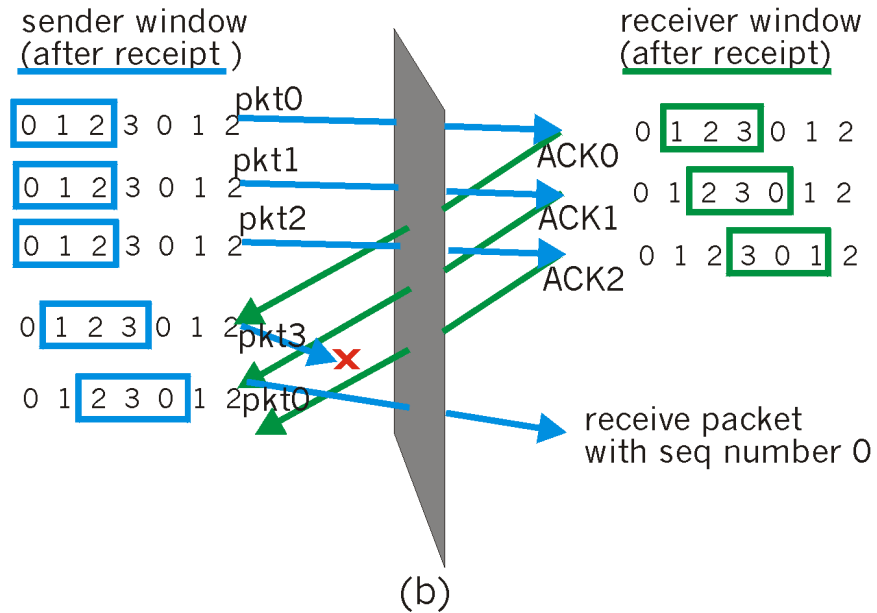
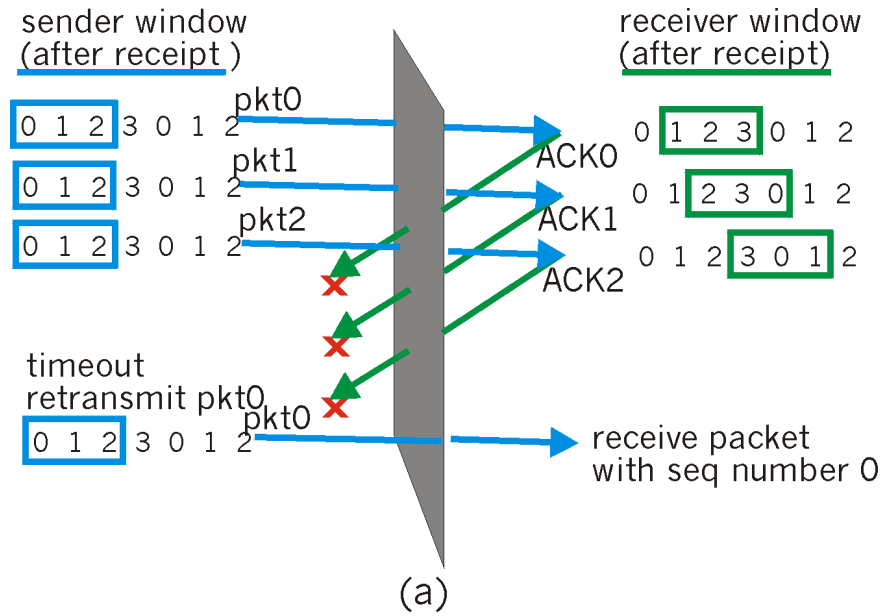

TCP vs. UDP

- Please name at least three differences between UDP and TCP.
 - TCP is connection oriented, UDP is not
 - TCP is a reliable data transfer protocol, UDP is not reliable
 - TCP enables in-order delivery, UDP does not guarantee in-order deliver
 - UDP has less overhead (lightweight) compared to TCP (heavy load due to ordering, window maintenance etc...)
 - TCP uses flow control, UDP does not
 - TCP uses congestion control, UDP does not

Choosing a protocol

- If you would like to transfer a file, which transport protocol would you use? Which protocol would you use for voice traffic?
 - File: TCP as it is reliable, in-order delivery.
Receiver can directly pipe data contents into file
 - Voice: UDP as it is lightweight, small in-orders cannot be heard and reliability has no advantage if delivery takes to long

TCP fast retransmit

- Please explain TCP fast retransmit.

- Time-out period often relatively long:
 - long delay before resending lost packet
- Detect lost segments via three duplicate ACKs.

Fast retransmit:

resend segment before timer expires, directly after receiving three duplicate acks

Flow vs. congestion control

- What is the difference between flow control and congestion control?
- **Flow Control**: Prevent overwhelming the receiver by sending too much data. Reduce sending rate if receiver's buffer fills up.
- **Congestion Control**: React on congestion in the network (on the path to the receiver). Reduce sending rates based on congestion observation (deduction by seeing delayed acks, lost acks etc.)

Estimated vs. sampled RTT

- Why is an EstimatedRTT used to calculate the TCP timeout instead of the recently sampled RTT?

- Exponential weighted moving average
- influence of past sample decreases exponentially fast

- SampleRTT fluctuates too much. EstimatedRTT + safety margin is a safer guess to set the timer.

