

# Exercise 8

# TCP congestion control

- N=200, RTT=200ms, MSS=1000 bytes, sender just sent a complete window!
  - a) Assuming no loss, what is the throughput (in terms of MSS and RTT and in terms of Megabit/s) of this message exchange?

$$\text{throughput} = \frac{\text{segments} \cdot \text{MSS}}{\text{RTT}} = \frac{200 \cdot 8000 \text{Bit}}{0.2 \text{s}} = 8000000 \frac{\text{Bit}}{\text{s}} = 8 \frac{\text{MBit}}{\text{s}}$$

# TCP congestion control cont'd

- b) Suppose TCP is in its congestion avoidance phase. Assuming no loss, what is the window size (in terms of segment) after the  $N = 200$  segments are acknowledged?
- From the lecture:
  - When `CongWin` is above `Threshold`, sender is in **congestion-avoidance** phase, window grows linearly.
  - `CongWin` is in units of MSS

# TCP sender congestion control

State	Event	TCP Sender Action	Commentary
Slow Start (SS)	ACK receipt for previously unacked data	$\text{CongWin} = \text{CongWin} + \text{MSS}$ , If ( $\text{CongWin} > \text{Threshold}$ ) set state to "Congestion Avoidance"	Resulting in a doubling of CongWin every RTT
Congestion Avoidance (CA)	ACK receipt for previously unacked data	$\text{CongWin} = \text{CongWin} + \text{MSS} * (\text{MSS} / \text{CongWin})$	Additive increase, resulting in increase of CongWin by 1 MSS every RTT
SS or CA	Loss event detected by triple duplicate ACK	$\text{Threshold} = \text{CongWin} / 2$ , $\text{CongWin} = \text{Threshold}$ , Set state to "Congestion Avoidance"	Fast recovery, implementing multiplicative decrease. CongWin will not drop below 1 MSS.
SS or CA	Timeout	$\text{Threshold} = \text{CongWin} / 2$ , $\text{CongWin} = 1 \text{ MSS}$ , Set state to "Slow Start"	Enter slow start
SS or CA	Duplicate ACK	Increment duplicate ACK count for segment being acked	CongWin and Threshold not changed

# TCP congestion control cont'd

- b) Suppose TCP is in its congestion avoidance phase. Assuming no loss, what is the window size (in terms of segment) after the  $N = 200$  segments are acknowledged? (CongWin = CW)
- in one RTT: 
$$CW = CW + MSS \cdot \left( \frac{MSS}{CW} \right)$$
- Each ack increases the CW by  $MSS/CW$ , which is  $8000\text{Bit}/200=40\text{Bit}$ . As 200 acks arrive, the window is increased by  $8000\text{Bit}$  which is exactly  $1MSS$ , therefore  $CW=200+1!$

# TCP-Reno and Tahoe

- What is the difference between the two congestion control algorithms TCP-Tahoe and TCP-Reno?

- Difference in handling time-outs and triple duplicate acks!

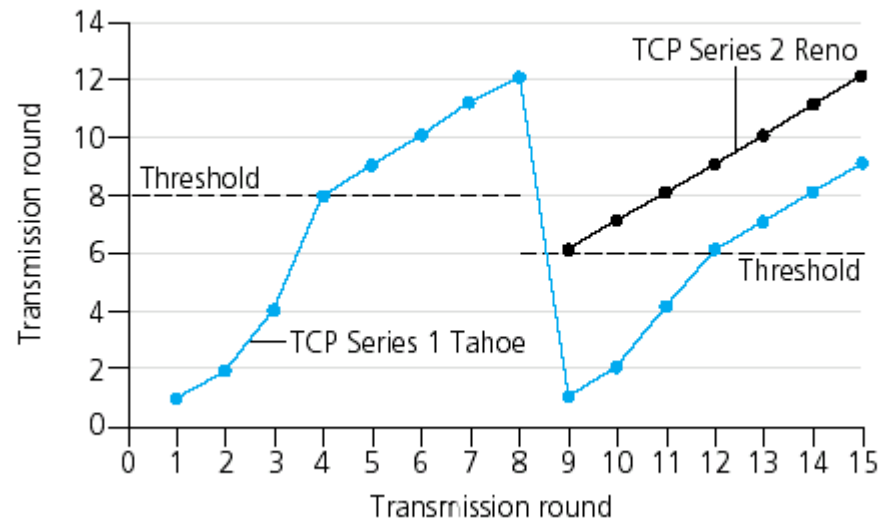

- Tahoe always down to 1MSS, Reno distinguishes: 3 duplicate ACKs-> go down to 50% then CA, timeout -> go down to 1MSS

# Selective Repeat

- Please explain the selective repeat dilemma and name a solution to prevent its occurrence.
- Dilemma occurs on a limited sequence range and large window size. Solution: Window size should be maximally half of the sequence range!

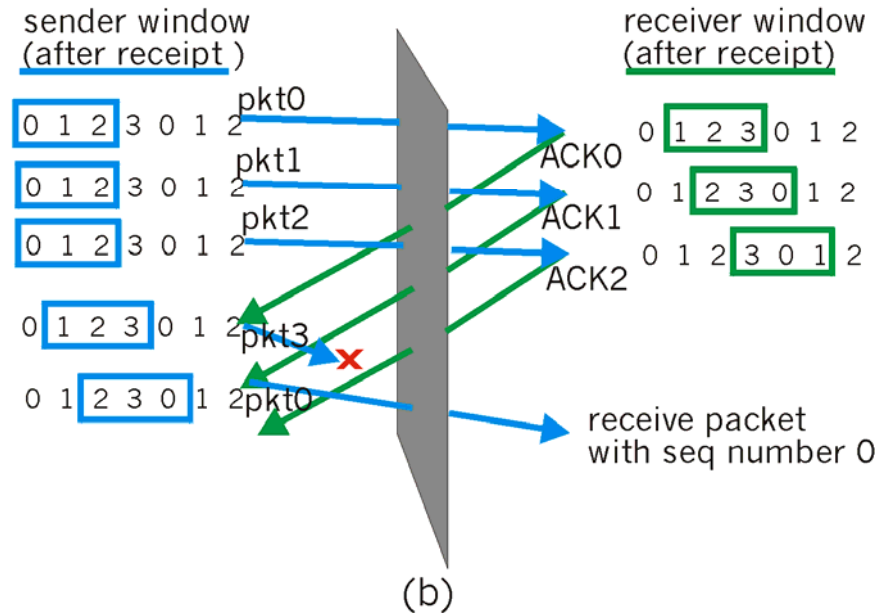
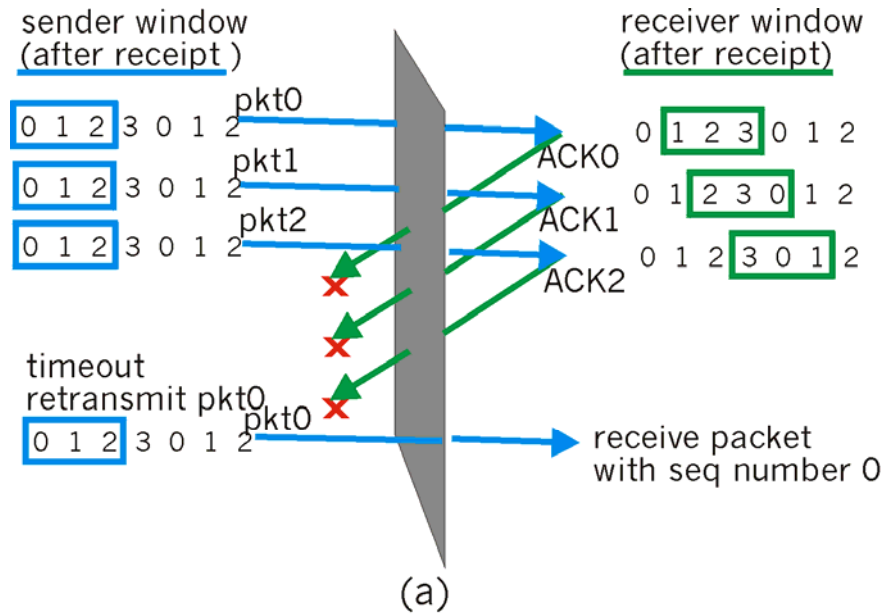



# TCP vs. UDP

- Please name at least three differences between UDP and TCP.
  - TCP is connection oriented, UDP is not
  - TCP is a reliable data transfer protocol, UDP is not reliable
  - TCP enables in-order delivery, UDP does not guarantee in-order deliver
  - UDP has less overhead (lightweight) compared to TCP (heavy load due to ordering, window maintenance etc...)
  - TCP uses flow control, UDP does not
  - TCP uses congestion control, UDP does not

# Choosing a protocol

- If you would like to transfer a file, which transport protocol would you use? Which protocol would you use for voice traffic?
  - File: TCP as it is reliable, in-order delivery.  
Receiver can directly pipe data contents into file
  - Voice: UDP as it is lightweight, small in-orders cannot be heard and reliability has no advantage if delivery takes to long

# TCP fast retransmit

- Please explain TCP fast retransmit.

- Time-out period often relatively long:
  - long delay before resending lost packet
- Detect lost segments via three duplicate ACKs.

## Fast retransmit:

resend segment before timer expires, directly after receiving three duplicate acks

# Flow vs. congestion control

- What is the difference between flow control and congestion control?
- **Flow Control**: Prevent overwhelming the receiver by sending too much data. Reduce sending rate if receiver's buffer fills up.
- **Congestion Control**: React on congestion in the network (on the path to the receiver). Reduce sending rates based on congestion observation (deduction by seeing delayed acks, lost acks etc.)

# Estimated vs. sampled RTT

- Why is an EstimatedRTT used to calculate the TCP timeout instead of the recently sampled RTT?

- Exponential weighted moving average
- influence of past sample decreases exponentially fast

- SampleRTT fluctuates too much. EstimatedRTT + safety margin is a safer guess to set the timer.

