

Transport Layer – Part I

Computer Networks, Winter 2017/2018

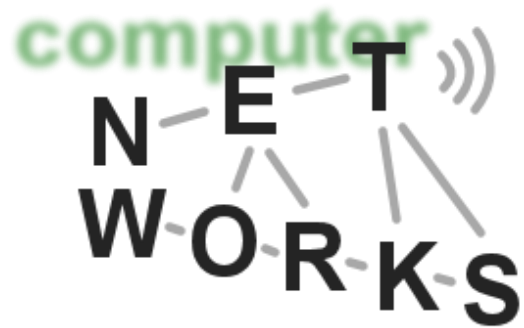

Chapter 4: The Transport Layer

5: Application Layer

4: Transport Layer

3: Network Layer

2: Link Layer

1: Physical Layer

Chapter 4: The Transport Layer

Our goals:

- understand principles behind transport layer services:
 - multiplexing/demultiplexing
 - reliable data transfer
 - flow control
 - congestion control
- learn about transport layer protocols in the Internet:
 - UDP: connectionless transport
 - TCP: connection-oriented transport
 - TCP congestion control

Transport Layer

- 3.1 Transport-layer services
- 3.2 Multiplexing and demultiplexing
- 3.3 Connectionless transport: UDP
- 3.4 Principles of reliable data transfer
- 3.5 Connection-oriented transport: TCP
 - segment structure
 - reliable data transfer
 - flow control
 - connection management
- 3.6 Principles of congestion control
- 3.7 TCP congestion control

Transport services and protocols

- provide *logical communication* between app processes running on different hosts
- transport protocols run in end systems
 - send side: breaks app messages into **segments**, passes to network layer
 - rcv side: reassembles segments into messages, passes to app layer
- more than one transport protocol available to apps
 - Internet: TCP and UDP

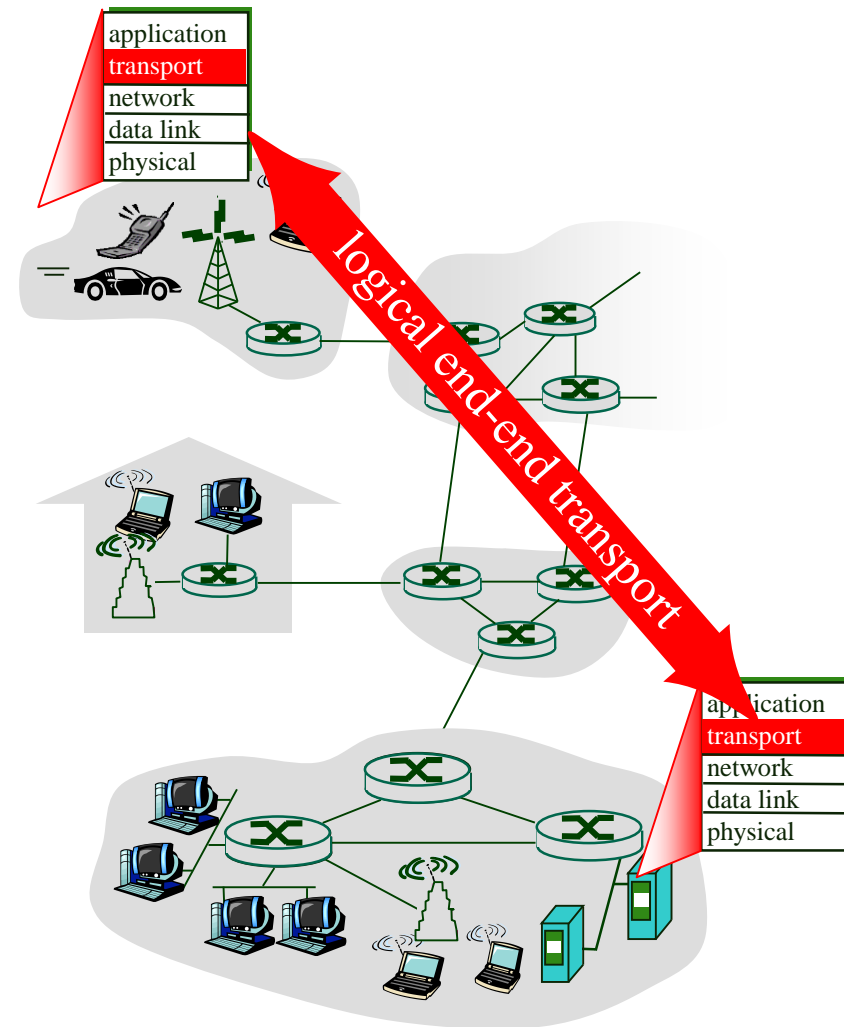

Transport vs. network layer

- *network layer*: logical communication between hosts
- *transport layer*: logical communication between processes
 - relies on & enhances, network layer services

Transport Protocol: Analogy

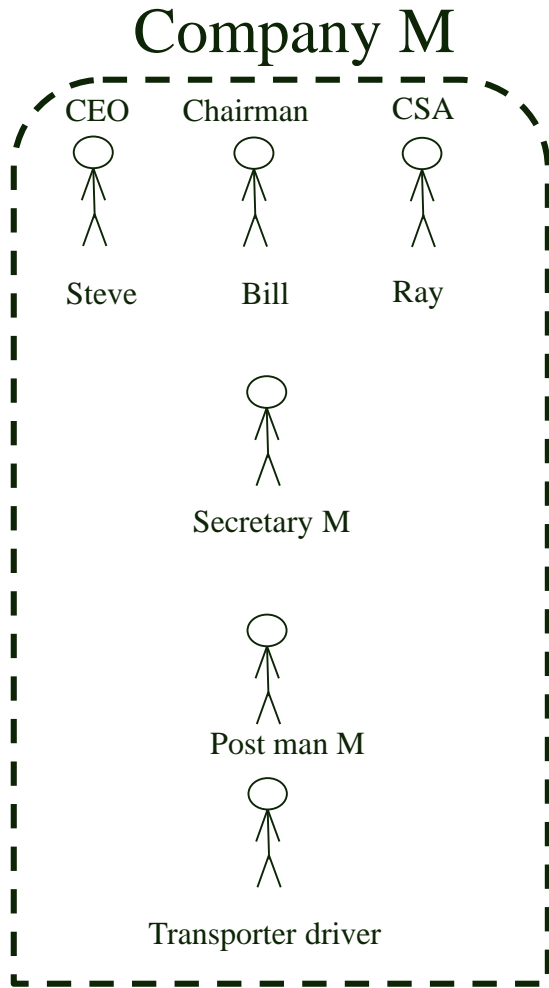

CEO = Chief Executive Officer
CSA = Chief Software Architect
TP = Technology President
PP = Products President

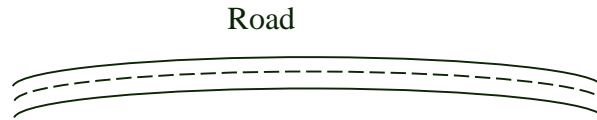
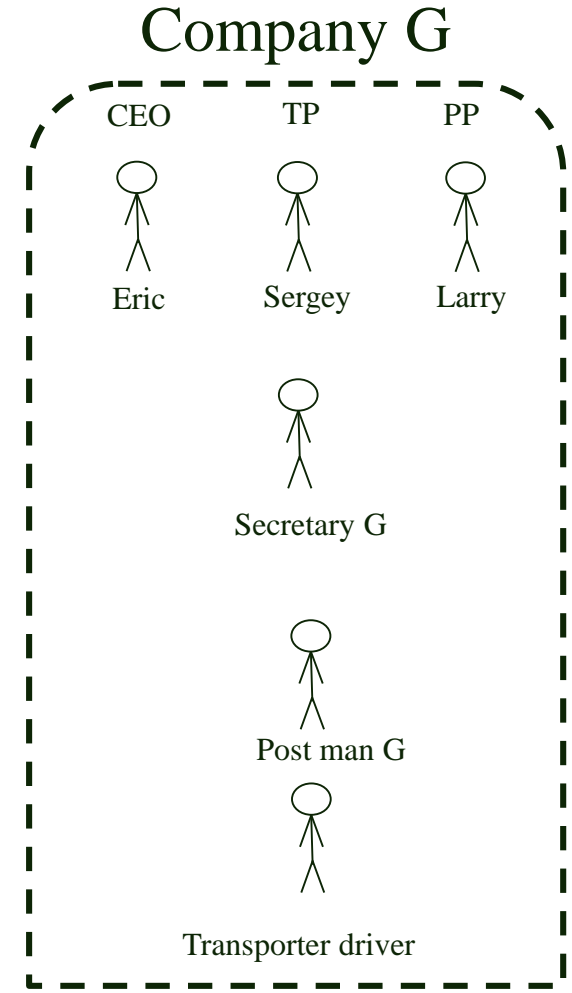

Transport Protocol: Analogy

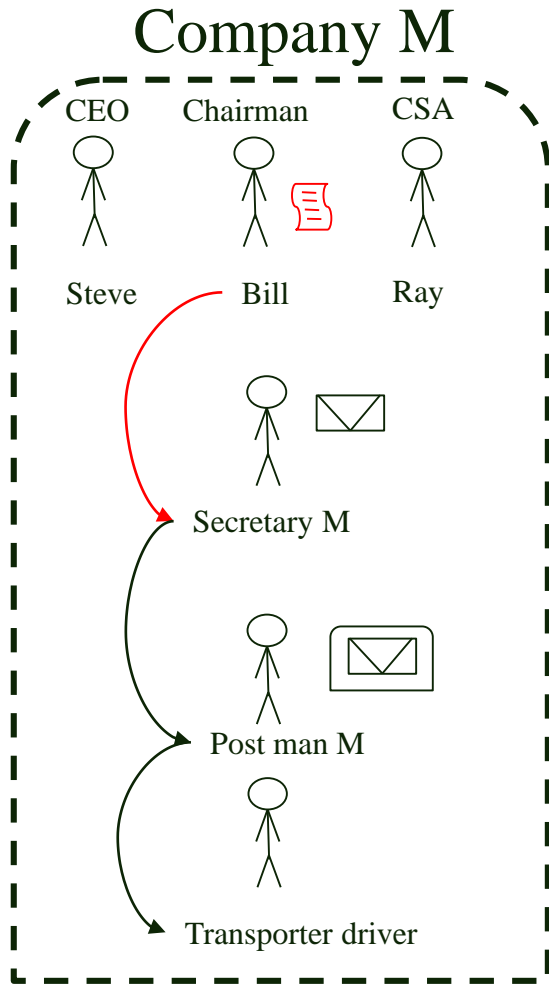

CEO = Chief Executive Officer
CSA = Chief Software Architect
TP = Technology President
PP = Products President

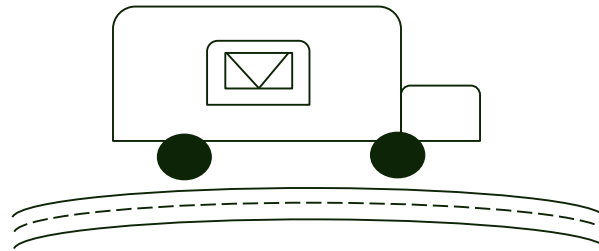

Road

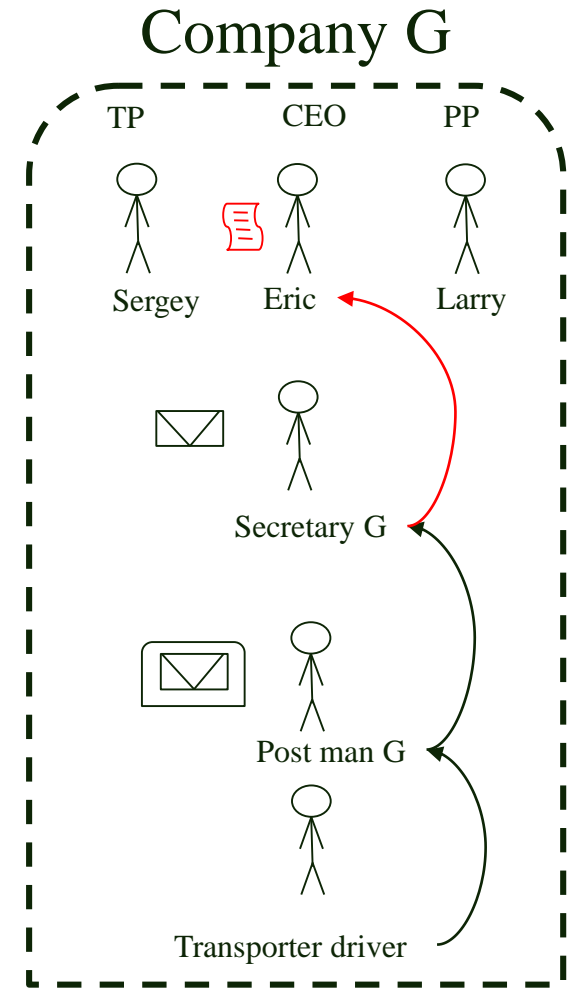

Transport Protocol: Analogy

- *Postal service (Network Layer):* logical communication between company buildings.
- *Secretary service (Transport Layer):* logical communication between employees of G und M.
 - relies on & enhances, postal services

Transport Protocol: Analogy

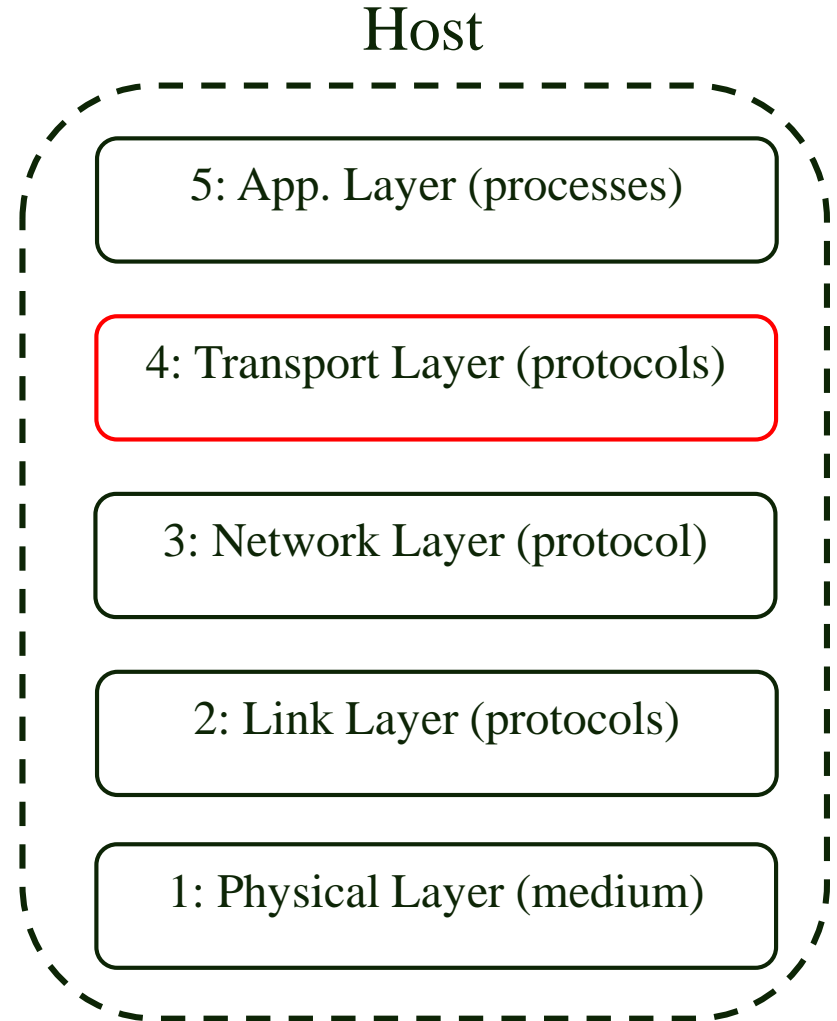
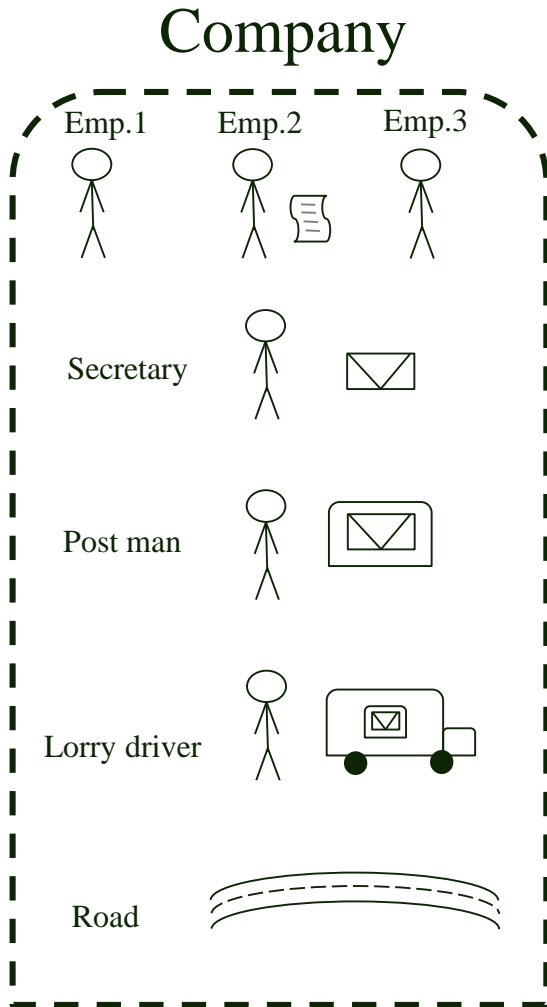

Transport Protocol: Analogy (Contd.)

- Network layer (IP) is similar to a postal service that does not offer “register post”, i.e. service without “einschreiben”
- How does the secretary know that the post was received
 - Imagine that the only mode of communication is via the postal service, i.e. there is no phones

Therefore, it becomes the job of the secretary to provide reliable or unreliable service to her boss

Also imagine that the secretary has to send 100s or 1000s of mails to convey the full message

Internet transport-layer protocols

- *unreliable*, unordered delivery: UDP
 - no-frills extension of “best-effort” IP
- *reliable*, in-order delivery (TCP)
 - congestion control
 - flow control
 - connection setup
- services not available:
 - delay guarantees
 - bandwidth guarantees

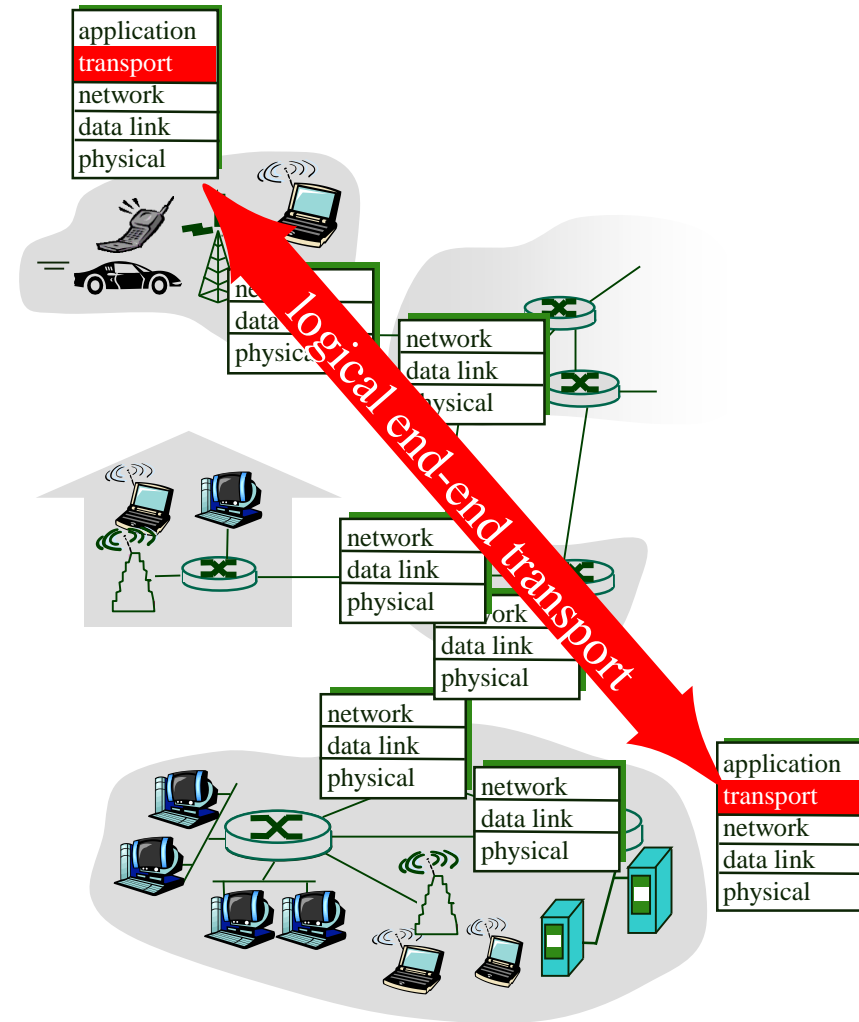

Excursus: Sockets

Socket API

- introduced in BSD4.1 UNIX, 1981
- explicitly created, used, released by apps
- client/server paradigm
- two types of transport service via socket API:
 - unreliable datagram
 - reliable, byte stream-oriented

socket

a *host-local*,
application-created,
OS-controlled interface (a
“door”) into which
application process can **both**
send and
receive messages to/from
another application process

Excursus: Socket programming *with TCP*

Socket: a door between application process and end-end-transport protocol (UDP or TCP)

TCP service: reliable transfer of **bytes** from one process to another

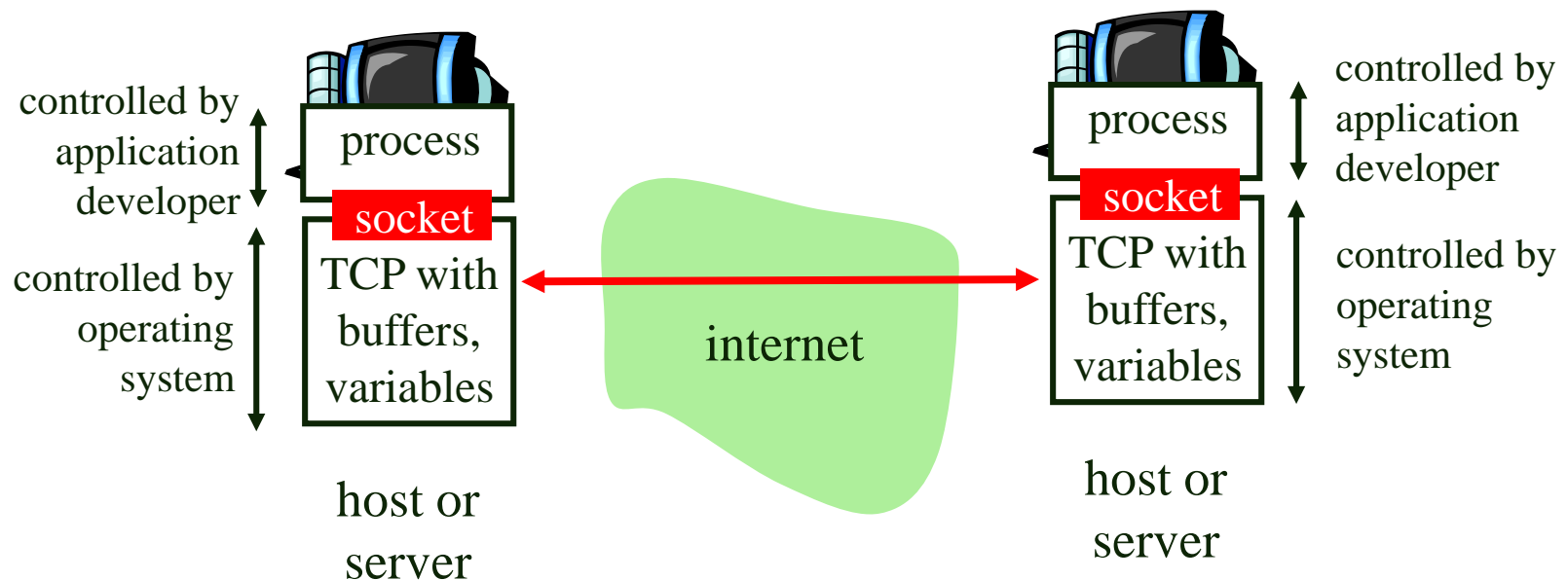

Excursus: Socket programming *with TCP*

Client must contact server

- server process must first be running
- server must have created socket (door) that welcomes client's contact

Client contacts server by:

- creating client-local TCP socket
- specifying IP address, port number of server process
- When **client creates socket**: client TCP establishes connection to server TCP

- When contacted by client, **server TCP creates new socket** for server process to communicate with client
 - allows server to talk with multiple clients
 - source port numbers used to **distinguish** clients

application viewpoint

TCP provides reliable, in-order transfer of bytes ("pipe") between client and server

Transport Layer

- 3.1 Transport-layer services
- 3.2 Multiplexing and demultiplexing
- 3.3 Connectionless transport: UDP
- 3.4 Principles of reliable data transfer
- 3.5 Connection-oriented transport: TCP
 - segment structure
 - reliable data transfer
 - flow control
 - connection management
- 3.6 Principles of congestion control
- 3.7 TCP congestion control

Multiplexing/demultiplexing

Multiplexing at send host:

gathering data from multiple sockets,
enveloping data with header
(later used for demultiplexing)

Demultiplexing at rcv host:

delivering received segments
to correct socket

 = socket  = process

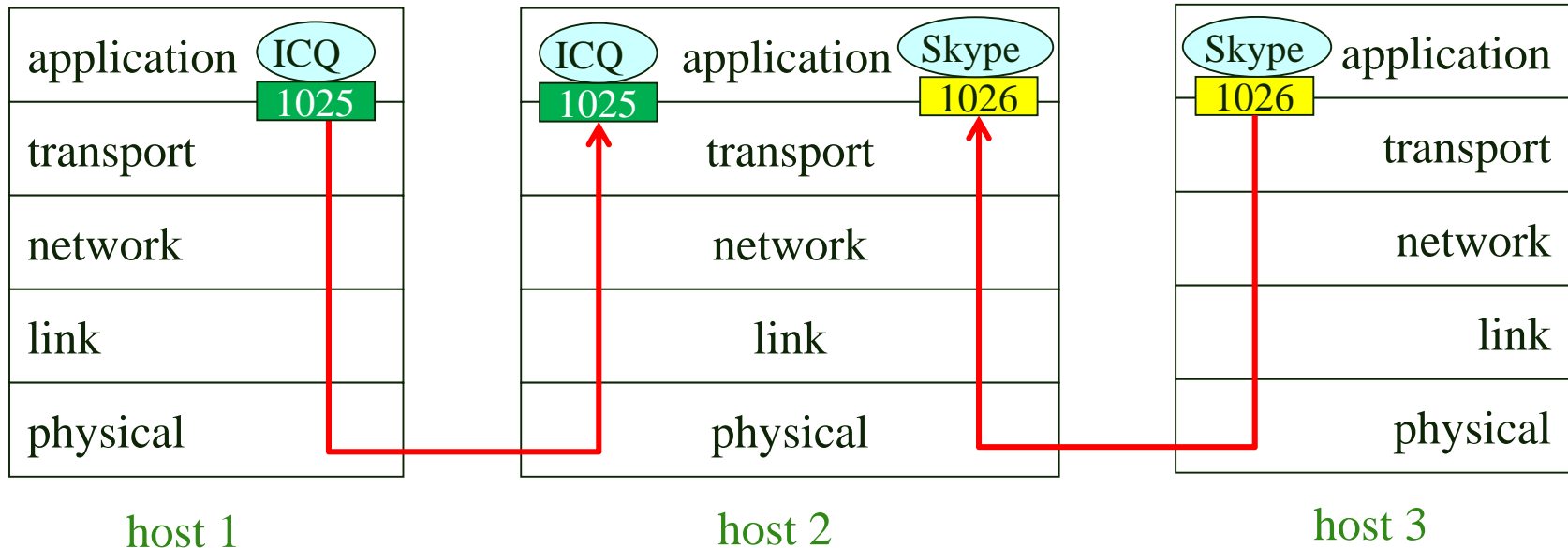

How demultiplexing works

- host receives IP datagrams
 - each datagram has source IP address, destination IP address
 - each datagram carries 1 transport-layer segment
 - each segment has source, destination port number
- host uses IP addresses & port numbers to direct segment to appropriate socket

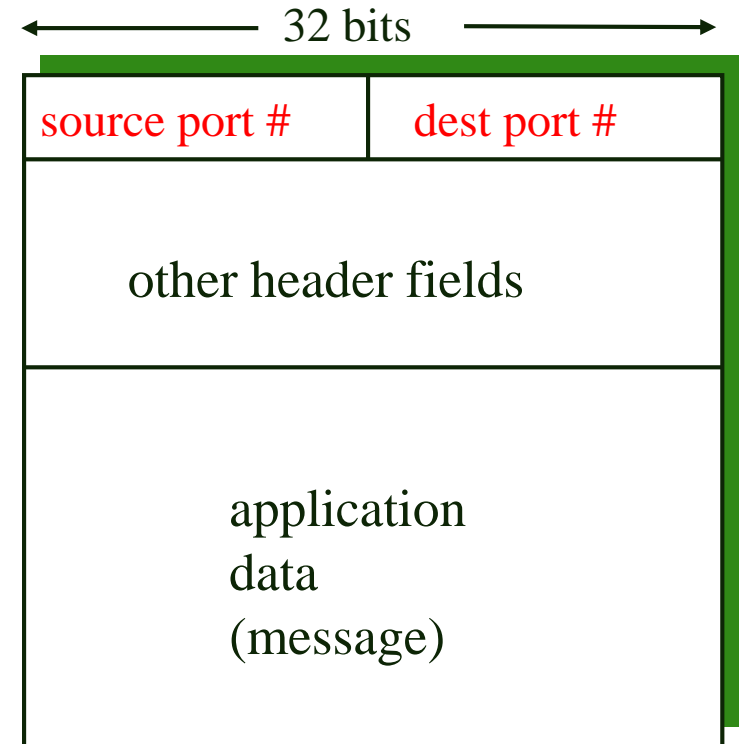

TCP/UDP segment format

Connectionless demultiplexing

- Create sockets with port numbers:

```
DatagramSocket clientSocket =  
    new DatagramSocket();
```

```
DatagramSocket serverSocket =  
    new DatagramSocket(6428);
```

- UDP socket identified by two-tuple:

(dest IP address, dest port number)

- When host receives UDP segment:
 - checks destination port number in segment
 - directs UDP segment to socket with that port number
- IP datagrams with different source IP addresses and/or source port numbers directed to same socket

Connectionless demux (cont)

```
DatagramSocket serverSocket = new DatagramSocket(6428);
```

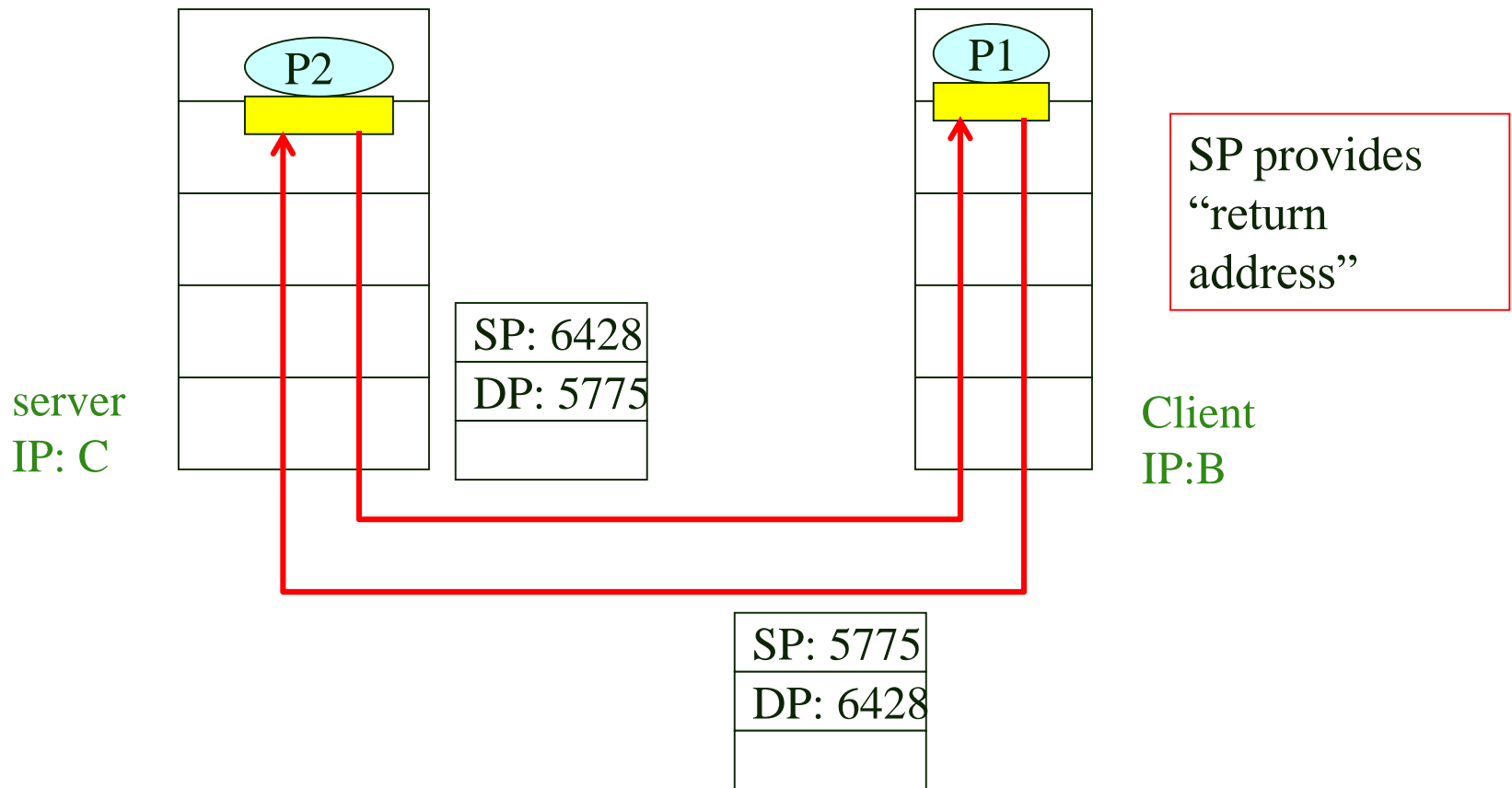

Connection-oriented demux

- TCP socket identified by 4-tuple:
 - source IP address
 - source port number
 - dest IP address
 - dest port number
- recv host uses all four values to direct segment to appropriate socket
- Server host may support many simultaneous TCP sockets:
 - each socket identified by its own 4-tuple
- Web servers have different sockets for each connecting client

Connection-oriented demux (cont)

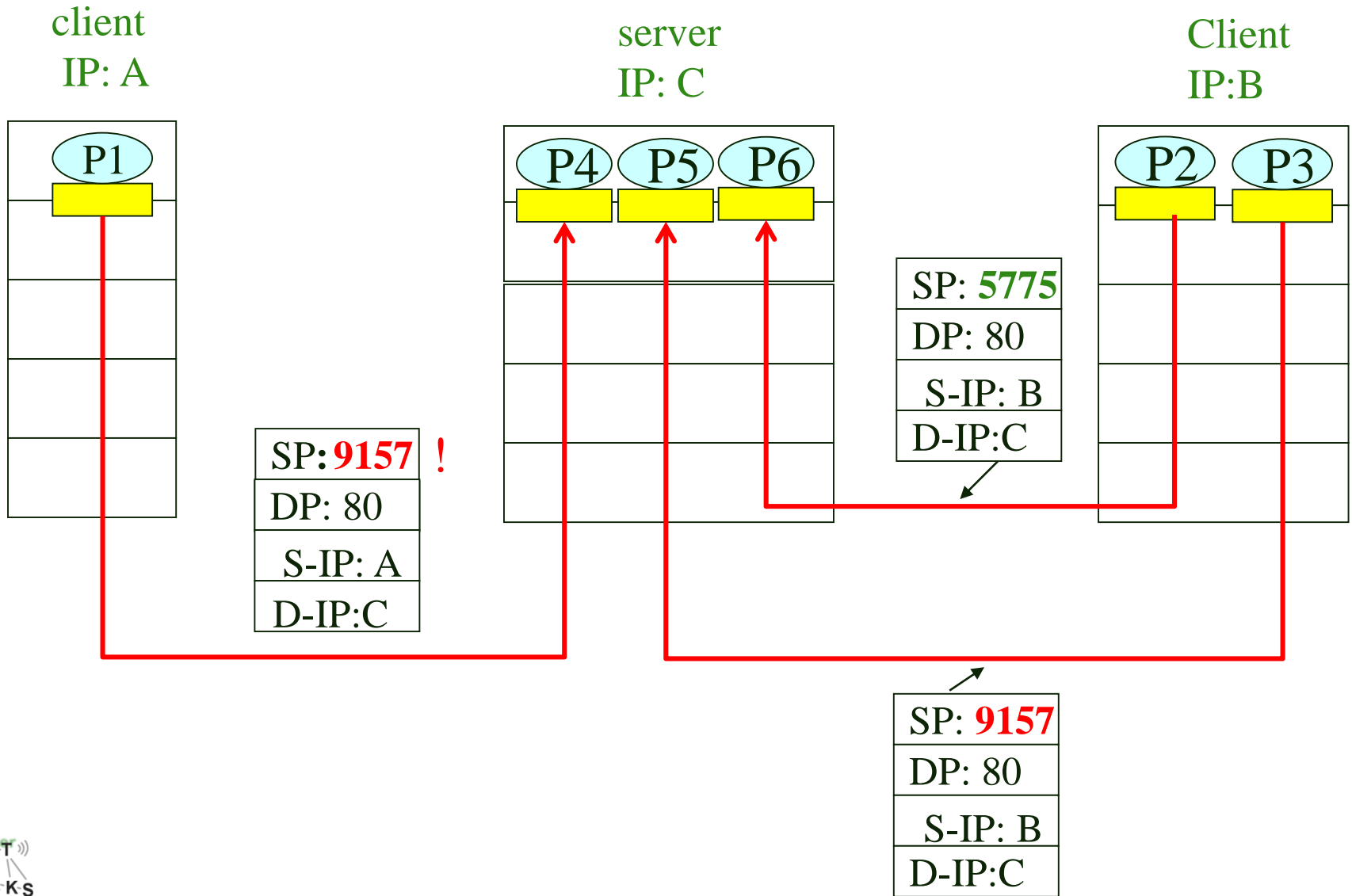

Connection-oriented demux (cont)

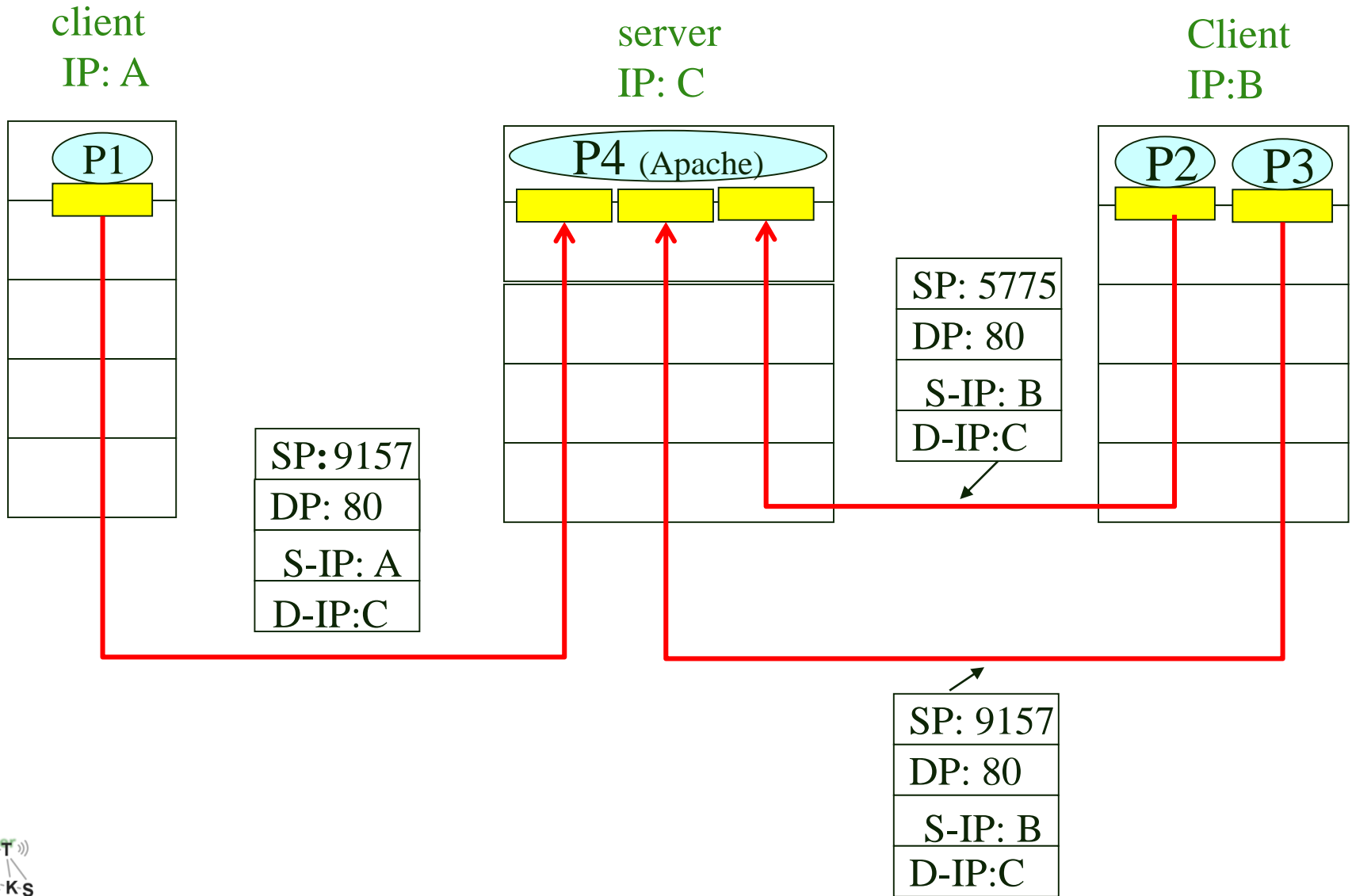

Transport Layer

- 3.1 Transport-layer services
- 3.2 Multiplexing and demultiplexing
- 3.3 Connectionless transport: UDP
- 3.4 Principles of reliable data transfer
- 3.5 Connection-oriented transport: TCP
 - segment structure
 - reliable data transfer
 - flow control
 - connection management
- 3.6 Principles of congestion control
- 3.7 TCP congestion control

The Problem with TCP

- TCP offers a **reliable** and **easy** to use transport protocol to programmers.
 - Congestion control
 - Retransmissions etc.
- However congestion control imposes transmission-rate **constraints**.
- If a traffic jam is detected on a path, sender **decreases** sending rate “dramatically”.
- **Problem**: One cannot “switch” off functions of TCP ex. Congestion control.

UDP: User Datagram Protocol [RFC 768]

- “no frills,” “bare bones” Internet transport protocol
- “best effort” service, UDP segments may be:
 - lost
 - delivered out of order to app
- *connectionless*:
 - no handshaking between UDP sender, receiver
 - each UDP segment handled **independently** of others

Why is there a UDP?

- no connection establishment (which can add delay)
- simple: no connection state (buffers & parameters) at sender, receiver
- small segment header (8 bytes v.s. 20 bytes)
- no congestion control & retransmission: UDP can blast away as fast as desired (e.g. used by VOIP)

UDP: more

- often used for streaming multimedia apps
 - loss tolerant
 - rate sensitive
- other UDP uses
 - DNS
 - SNMP
- reliable transfer over UDP: add reliability at application layer
 - application-specific error recovery!
 - ex. ACK/NAK, retransmissions (**non-trivial**).

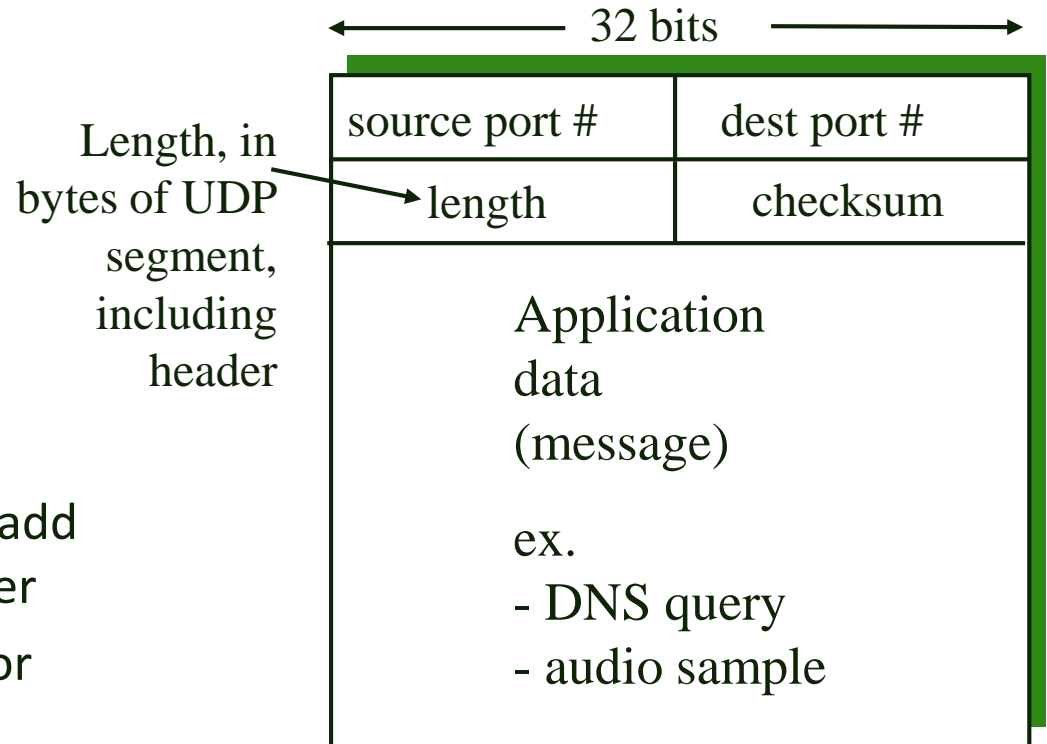

UDP segment format

UDP checksum

Goal: detect “errors” (e.g., flipped bits) in transmitted segment

Sender:

- treat segment contents as sequence of 16-bit integers
- checksum: addition (1’s complement sum) of segment contents
- sender puts checksum value into UDP checksum field

Receiver:

- compute checksum of received segment
- check if computed checksum equals checksum field value:
 - NO - error detected
 - YES - no error detected. *But maybe errors nonetheless?*
More later

UDP checksum example

- Lets take the word “hi” (8bit ASCII)
- Convert it to binary
 - h = 01101000
 - i = 01101001

- Add both words

$$\begin{array}{r} 01101000 \text{ (h)} \\ + 01101001 \text{ (i)} \\ \hline 11010001 \text{ (h+i)} \end{array}$$

- UDP checksum works with 16 Bit words, but we use 8 Bits for simplicity

- The 1s complement is obtained by inverting ones to zeros and vice versa.
- 11010001 -> 00101110 (checksum)

UDP checksum example

- Check (unaltered bits):

$$\begin{array}{r}
 01101000 \text{ (h)} \\
 + 01101001 \text{ (i)} \\
 \hline
 11010001 \text{ (h+i)} \\
 + 00101110 \text{ (checksum)} \\
 \hline
 11111111 \text{ (OK)}
 \end{array}$$

- Check (altered bits):

$$\begin{array}{r}
 01101000 \text{ (h)} \\
 + 011010\mathbf{11} \text{ (i)} \\
 \hline
 110100\mathbf{11} \text{ (h+i)} \\
 + 00101110 \text{ (checksum)} \\
 \hline
 1000000\mathbf{1} \text{ (NOK!)}
 \end{array}$$

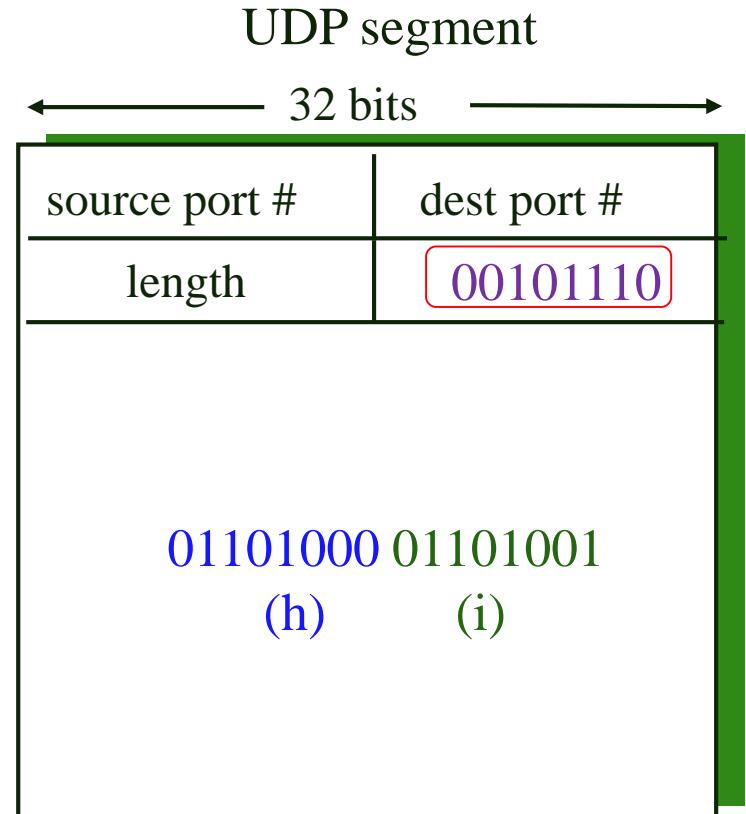

UDP checksum

- Why error detection in the first place?
- Link Layer provides CRC! (Ethernet)
- No guarantee for:
 - link-to-link reliability (e.g. non ethernet)
 - memory error detection on routers
- IP is designed to run on any layer 2 protocol (ethernet, PPP, 802.11, 802.16).
- End-to-end error detection is safety measure
- UDP does not recover from errors (discard/warning)

Transport Layer

- 3.1 Transport-layer services
- 3.2 Multiplexing and demultiplexing
- 3.3 Connectionless transport: UDP
- 3.4 Principles of reliable data transfer
- 3.5 Connection-oriented transport: TCP
 - segment structure
 - reliable data transfer
 - flow control
 - connection management
- 3.6 Principles of congestion control
- 3.7 TCP congestion control

Principles of Reliable data transfer

- important in app., transport, link layers
- top-10 list of important networking topics!

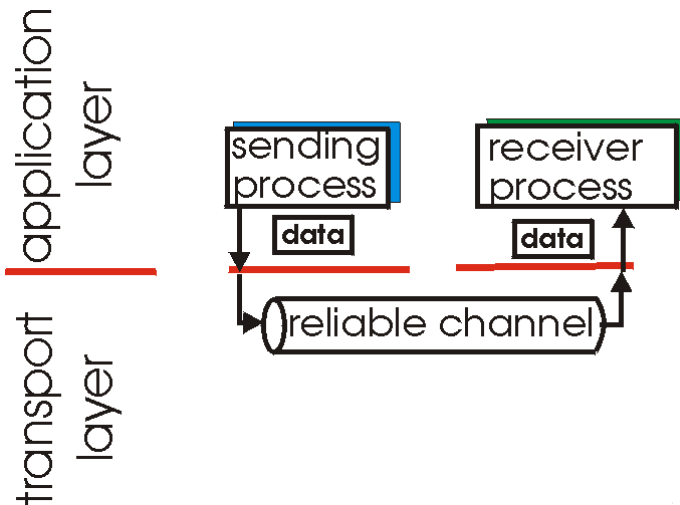

(a) provided service

- characteristics of unreliable channel will determine complexity of reliable data transfer protocol (rdt)

Principles of Reliable data transfer

- important in app., transport, link layers
- top-10 list of important networking topics!

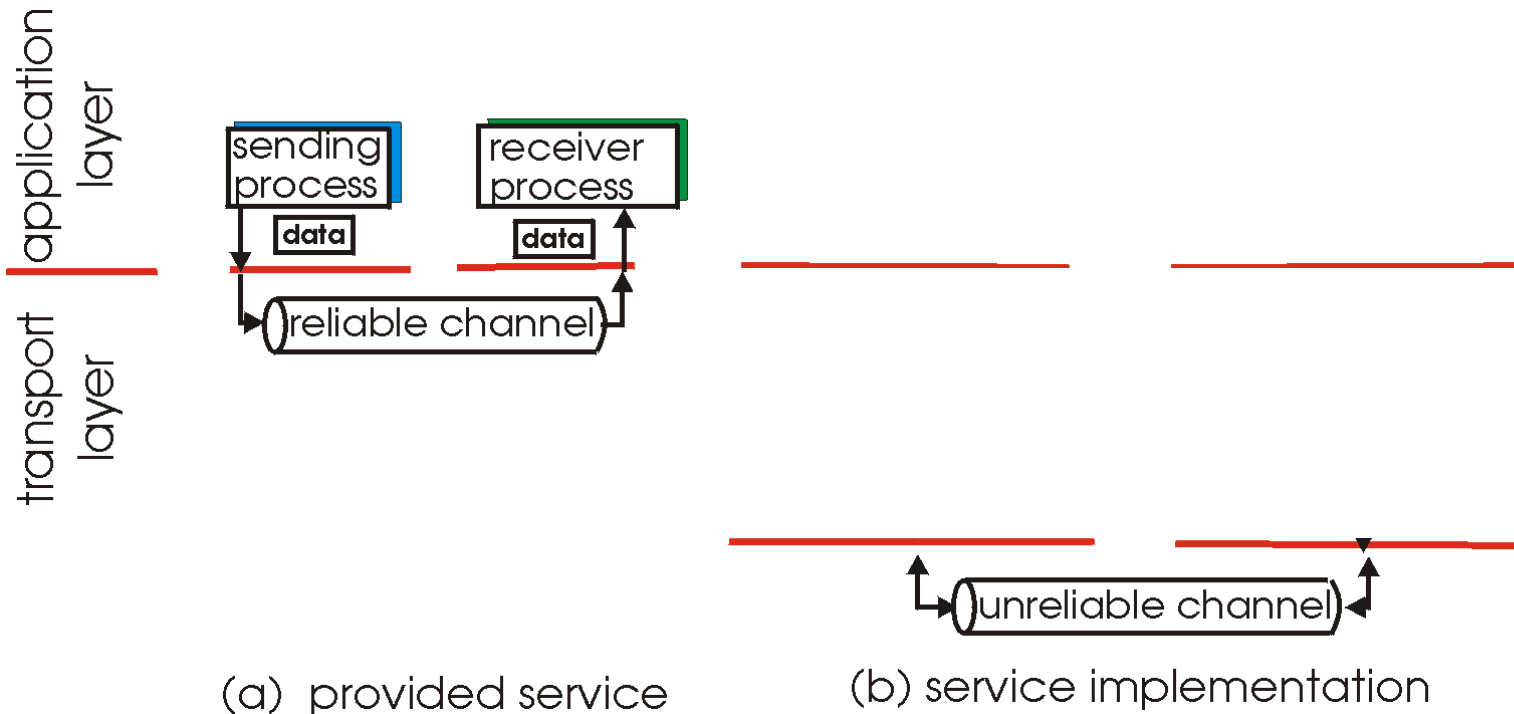

- characteristics of unreliable channel will determine complexity of reliable data transfer protocol (rdt)

Principles of Reliable data transfer

- important in app., transport, link layers
- top-10 list of important networking topics!

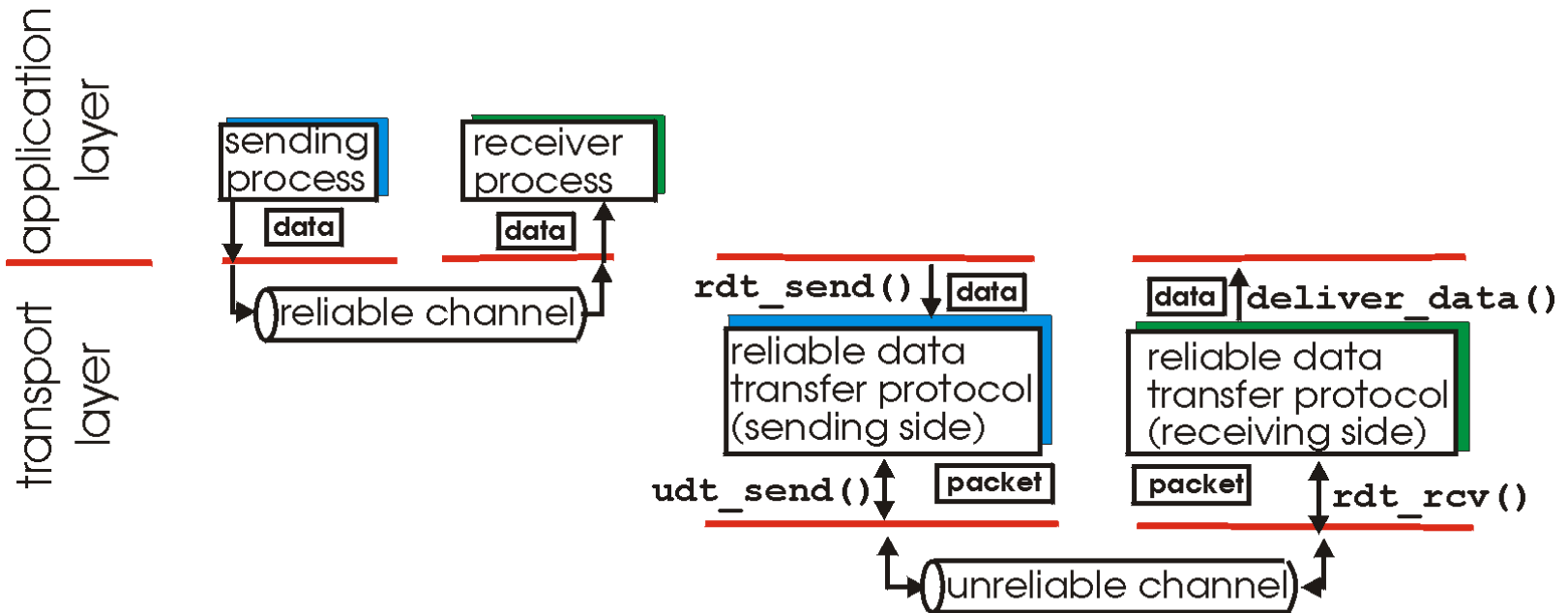

(a) provided service

(b) service implementation

- characteristics of unreliable channel will determine complexity of reliable data transfer protocol (rdt)

Reliable data transfer: getting started

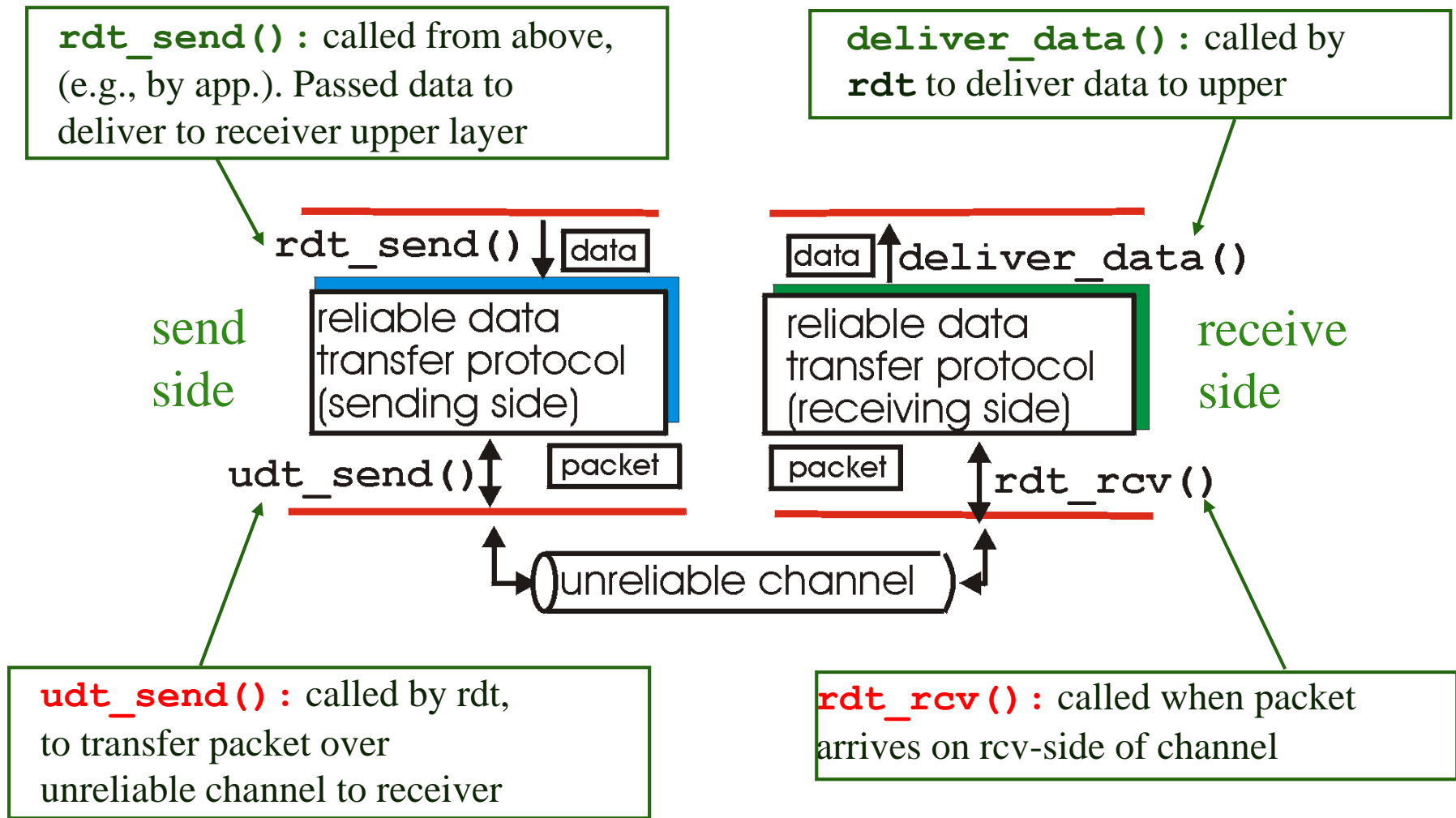

Reliable data transfer: getting started

We'll:

- incrementally develop sender, receiver sides of reliable data transfer protocol (rdt)
- consider only unidirectional data transfer
 - but control info will flow on both directions!
- use finite state machines (FSM) to specify sender, receiver
- Use generic term “packet” rather than “segment”

Finite State Machine

- FSM is a model of behavior composed of a finite number of
 - states
 - transitions between states on events
 - actions taken upon events
- Necessary to define the behavior of our protocol, prior to implementation

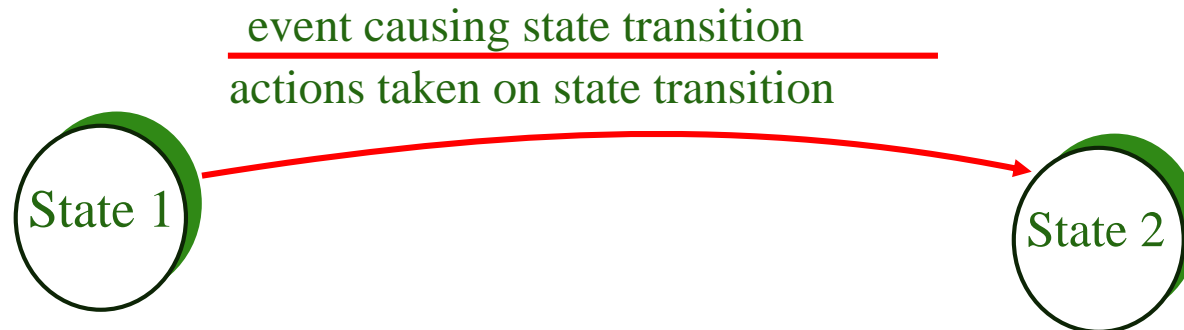

Rdt1.0: reliable transfer over a reliable channel

- **Assumption:** underlying channel perfectly reliable
 - no bit errors
 - no loss of packets
- separate FSMs for sender, receiver:
 - sender sends data into underlying channel
 - receiver read data from underlying channel
- We will first look at an analogy with the secretary then the state machines.

Rdt1.0: reliable transfer over a reliable channel (Analogy)

- The secretary from our previous example has one state

- He waits for tasks from his boss

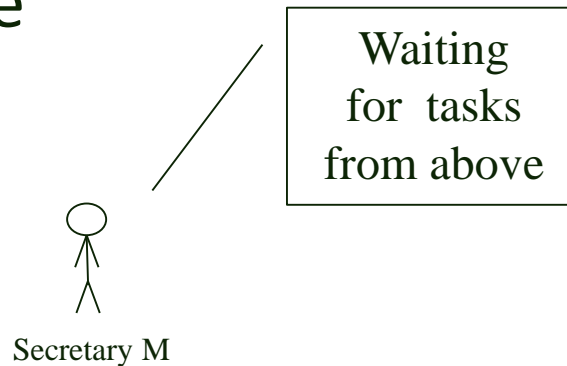

- Task is sending letters

Rdt1.0: reliable transfer over a reliable channel (Analogy)

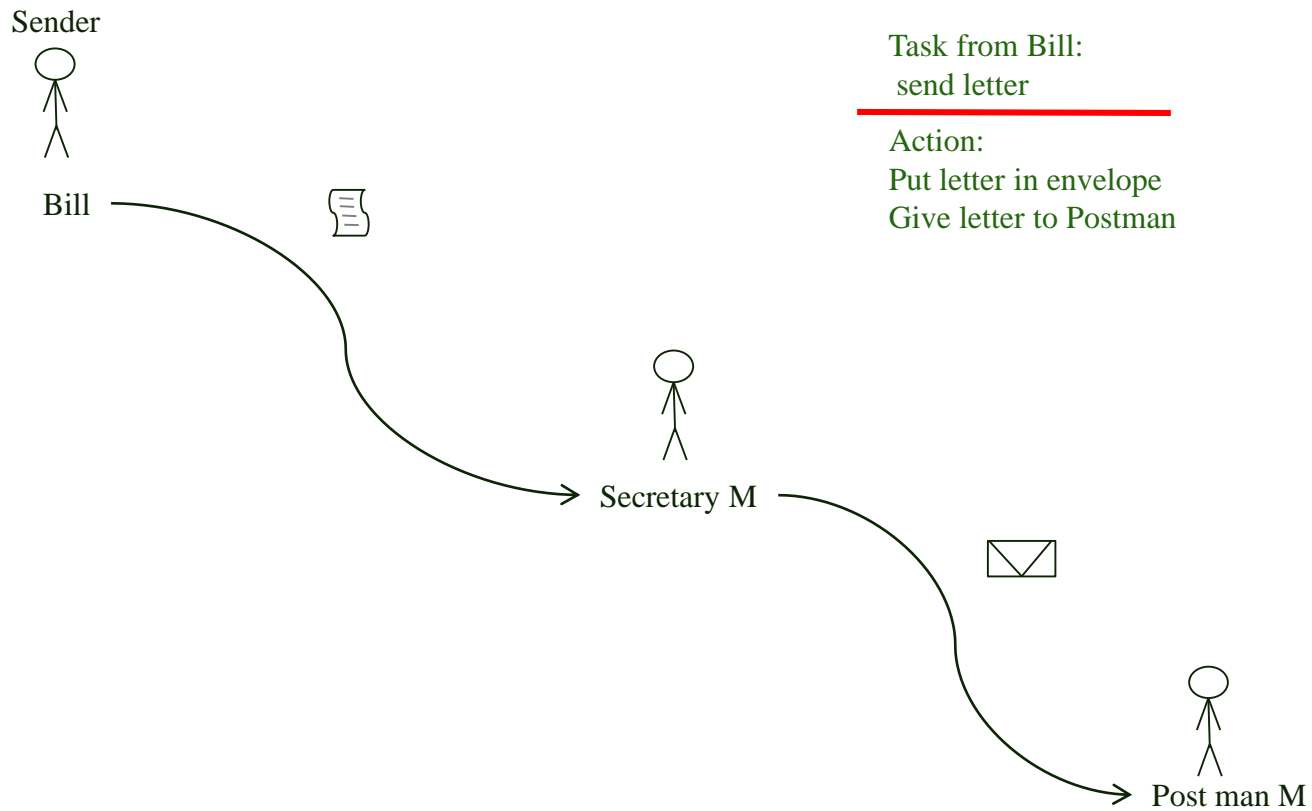

event → transition
transition → action

Rdt1.0: reliable transfer over a reliable channel (Analogy)

- The secretary goes back to his state, waiting for more tasks.

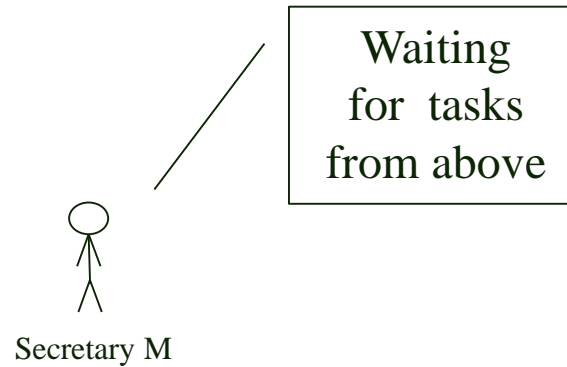

Rdt1.0: reliable transfer over a reliable channel

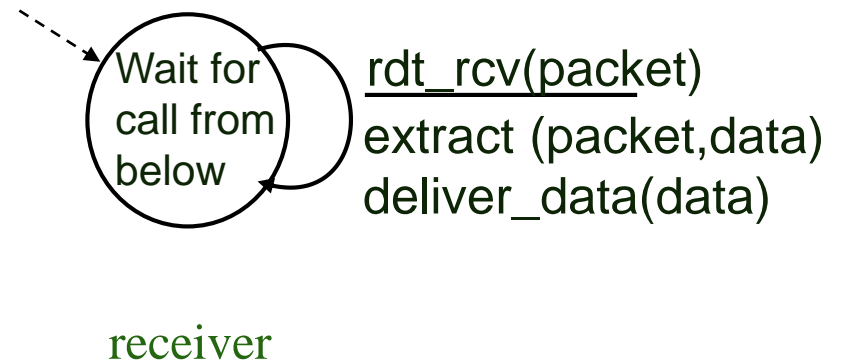
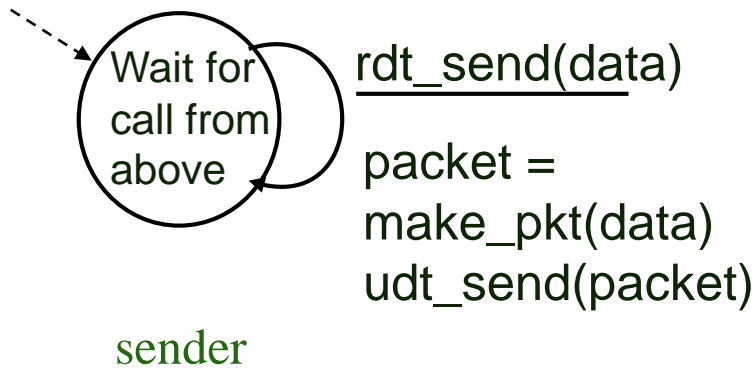

event → transition
transition → action
 Λ = no event/action

Rdt2.0: channel with bit errors

- underlying channel may flip bits in packet
 - checksum to detect bit errors 00101110
- **the question:** how to recover from errors?
- **Analogy:**
 - Imagine you dictate phone number over cell phone to friend.
 - Bad reception may scramble your voice.

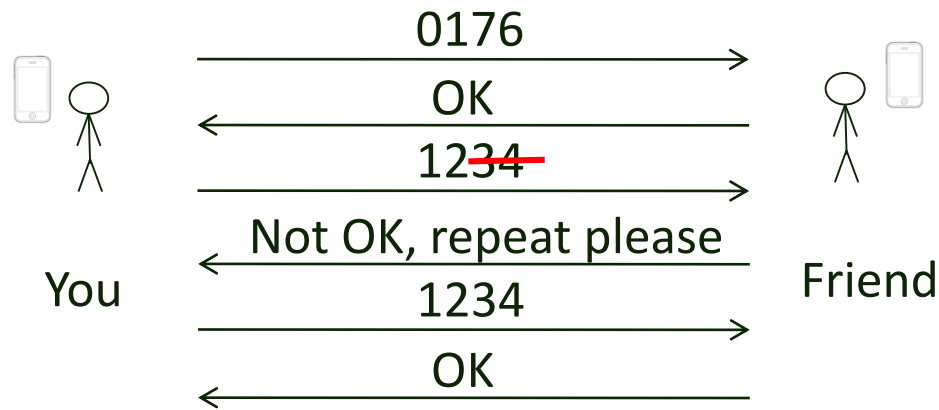

Rdt2.0: channel with bit errors

- *acknowledgements (ACKs)*: receiver explicitly tells sender that pkt received OK
- *negative acknowledgements (NAKs)*: receiver explicitly tells sender that pkt had errors
 - sender retransmits pkt on receipt of NAK
- new mechanisms in **rdt2.0** (beyond **rdt1.0**):
 - error detection
 - receiver feedback: control msgs (ACK,NAK) rcvr->sender
- **A**utomatic **R**epeat re**Q**uest type of protocol (**ARQ**)

rdt2.0: FSM specification

```

rdt_send(data)
snpkt = make_pkt(data, checksum)
udt_send(sndpkt)

```

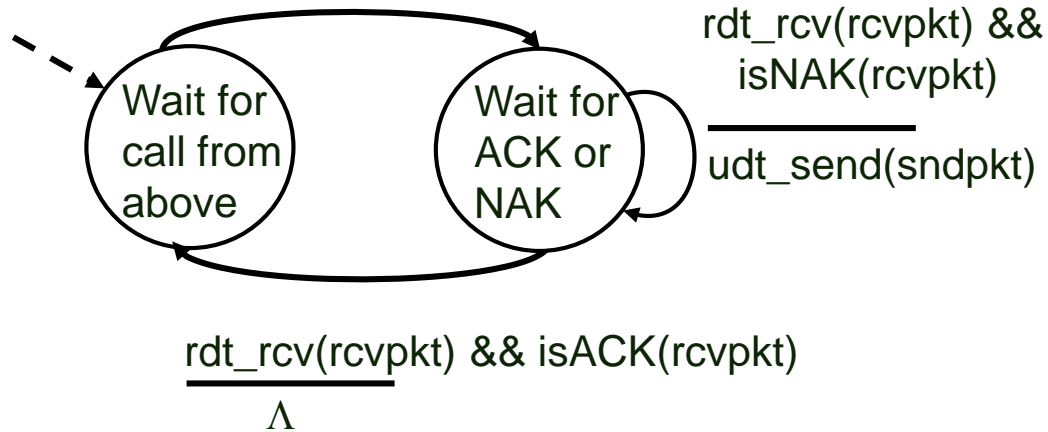

sender

event → transition
 transition → action
 Λ = no event/action

receiver

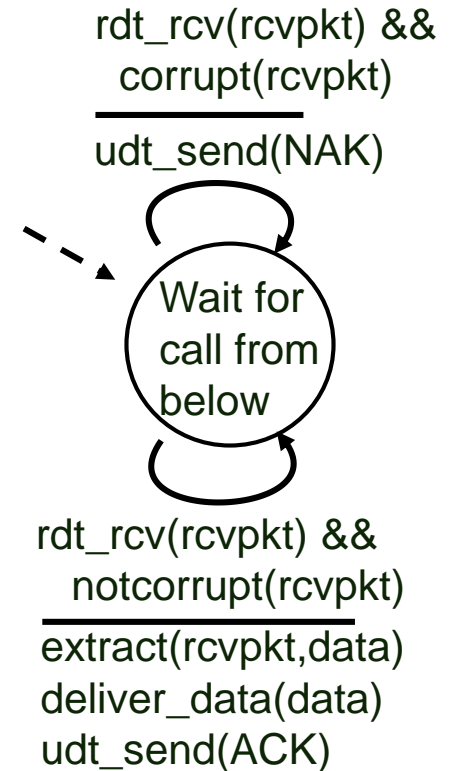

rdt2.0 has a fatal flaw!

What happens if ACK/NAK corrupted?

- sender doesn't know what happened at receiver!
- can't just retransmit: possible duplicate

Handling duplicates:

- sender retransmits current pkt if ACK/NAK garbled
- sender adds *sequence number* to each pkt
- receiver discards (doesn't deliver up) duplicate pkt

Using only ACK + Sequence:

- We can **discard** NAK packets, by using only ACK + Seq.#
- duplicate ACK at sender results in same action as NAK:
retransmit current pkt

stop and wait

Sender sends one packet,
then waits for receiver
response

rdt2.2: sender, handles garbled ACKs

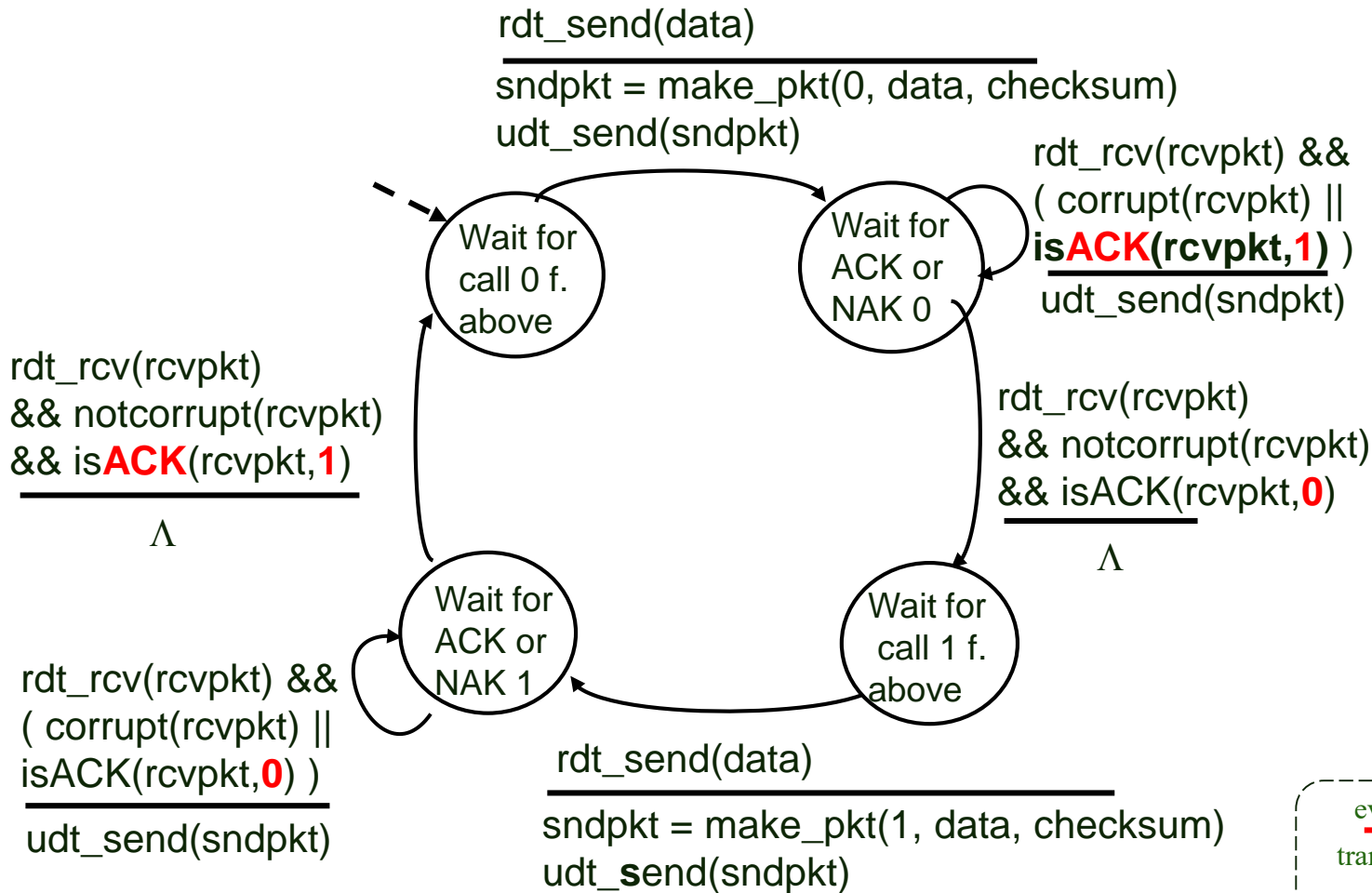

rdt2.2: receiver, handles garbled ACKs

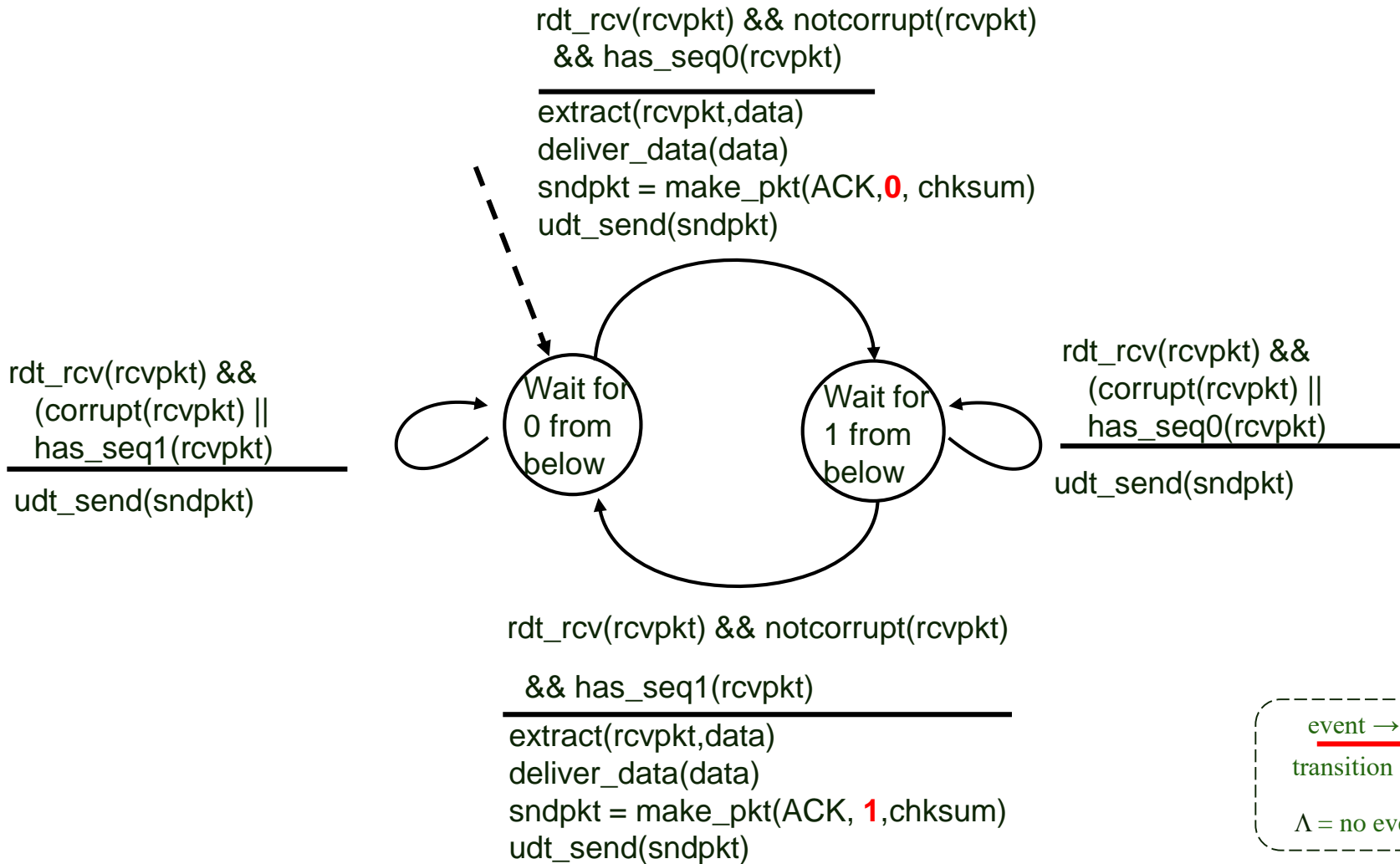

event → transition
 transition → action
 Λ = no event/action

rdt2.2: discussion

Sender:

- seq # added to pkt
- two seq. #'s (0,1) will suffice. Why?
- must check if received ACK corrupted
- twice as many states
 - state must “remember” whether “current” pkt has 0 or 1 seq. #

Receiver:

- must check if received packet is duplicate
 - state indicates whether 0 or 1 is expected pkt seq #
- note: receiver can *not* know if its last ACK received OK at sender

rdt: What do we have so far?

- rdt 1.0

- simple transfer over reliable channel (unrealistic)



- rdt 2.0

- bit error prone channel (more realistic)
- checksum (data), ACK/NAK, retransmit
- **but what if ACK corrupt?**



- rdt 2.2

- checksum (data & ACK)
- retransmit if ACK corrupt
- **but what if data OK, but ACK corrupt? -> duplicate**
- introduce sequence numbers (more states)
- slimed down: discard NAK by introducing seq. in ACK
- **but what if channel loses packets?**

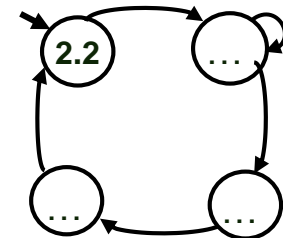

rdt3.0: channels with errors *and* loss

New assumption: underlying channel can also lose packets (data or ACKs)

- checksum, seq. #, ACKs, retransmissions will be of help, but not enough

Approach: sender waits “reasonable” amount of time for ACK

- retransmits if no ACK received in this time
- if pkt (or ACK) just delayed (not lost):
 - retransmission will be duplicate, but use of seq. #'s already handles this
 - receiver must specify seq # of pkt being ACKed
- requires countdown timer

rdt3.0 sender

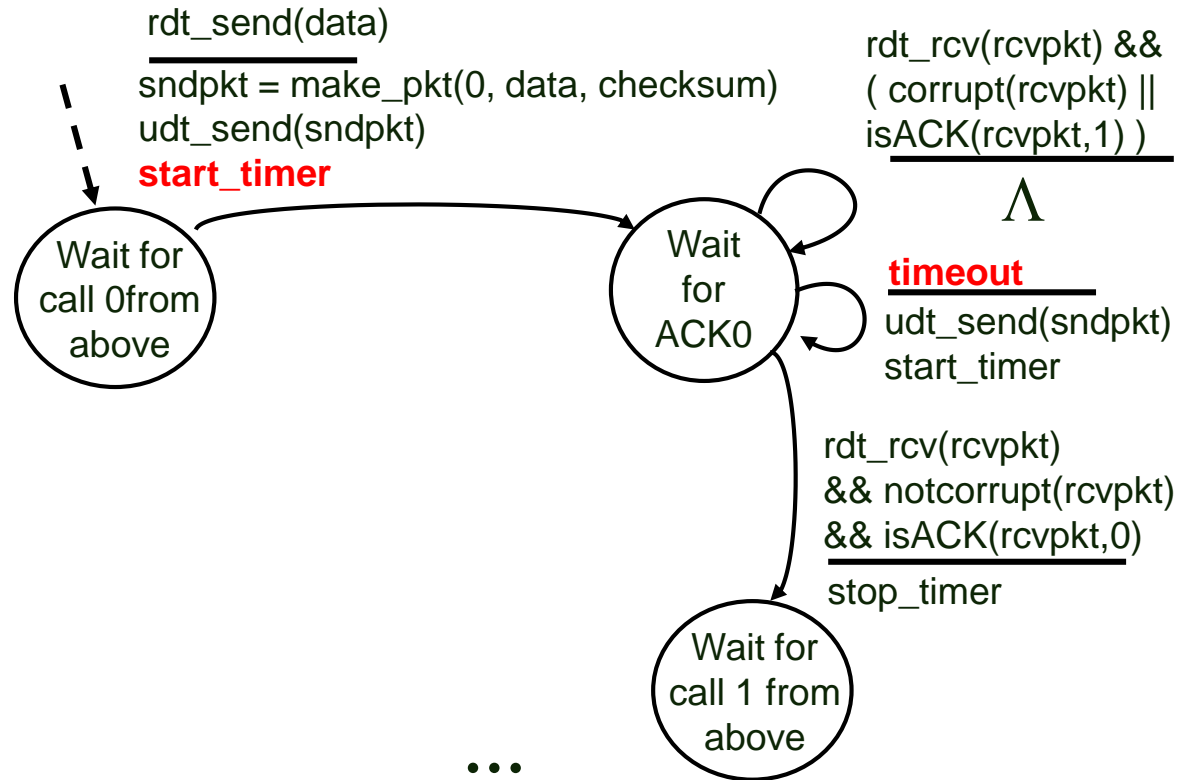

event → transition
 transition → action
 Λ = no event/action

rdt3.0 in action

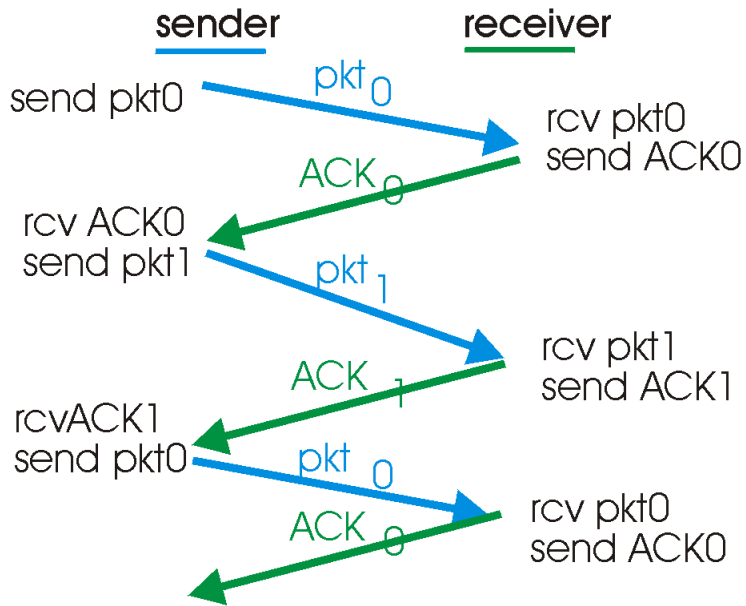

(a) operation with no loss

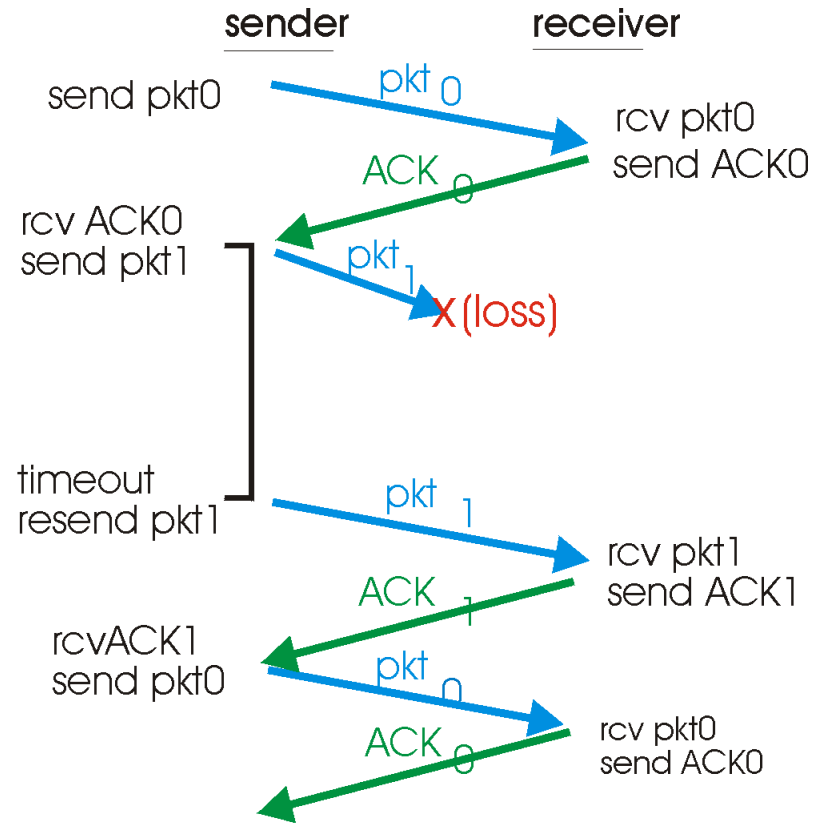

(b) lost packet

rdt3.0 in action

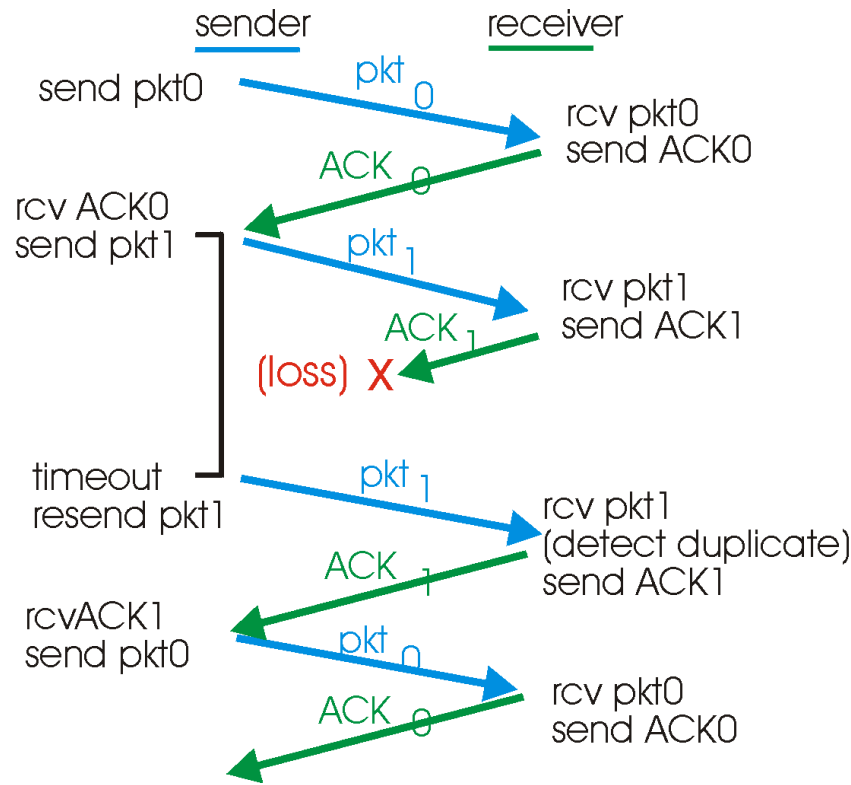

(c) lost ACK

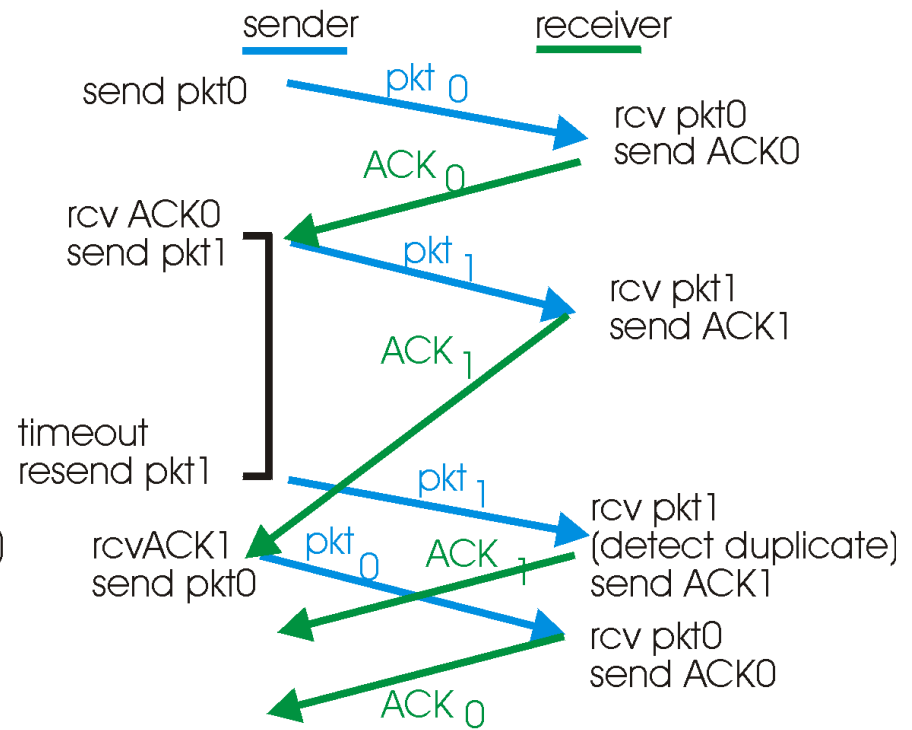

(d) premature timeout

Performance of rdt3.0

- rdt3.0 works, but performance stinks
- ex: 1 Gbps link, 15 ms prop. delay, 8000 bit packet:

$$d_{trans} = \frac{L}{R} = \frac{8000\text{bits}}{10^9\text{bps}} = 8\text{microseconds}$$

- U_{sender} : **utilization** – fraction of time sender busy sending

$$U_{\text{sender}} = \frac{L/R}{RTT + L/R} = \frac{.008}{30.008} = 0.00027$$

- 1KB pkt every 30 msec -> 33kB/sec thrupt over 1 Gbps link
- network protocol limits use of physical resources!

rdt3.0: stop-and-wait operation

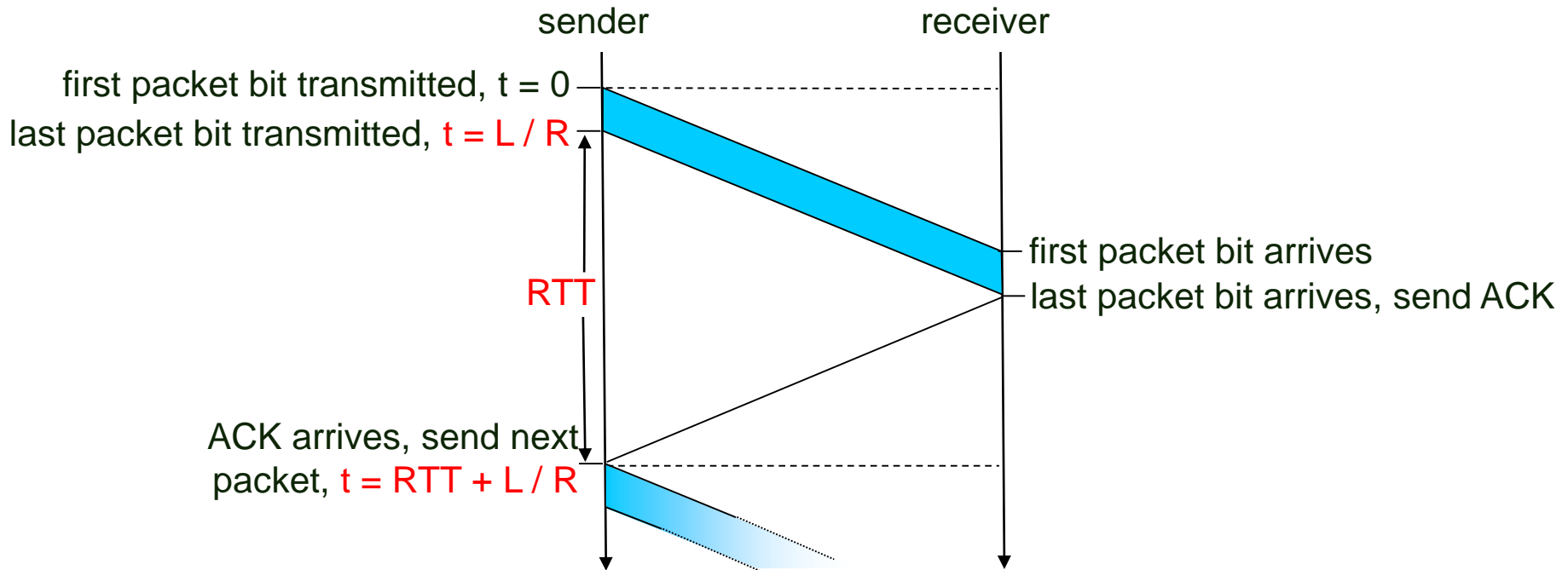

$$U_{\text{sender}} = \frac{L/R}{RTT + L/R} = \frac{.008}{30.008} = 0.00027$$

Pipelined protocols

Pipelining: sender allows multiple, “in-flight”, yet-to-be-acknowledged pkts

- range of sequence numbers must be increased
- buffering at sender and/or receiver

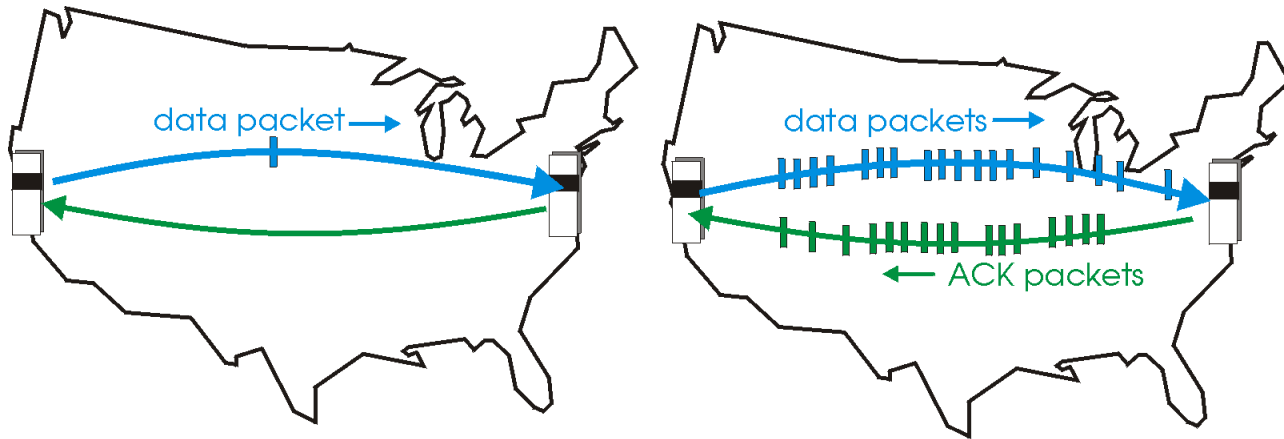

(a) a stop-and-wait protocol in operation

(b) a pipelined protocol in operation

- Two generic forms of pipelined protocols: *go-Back-N*, *selective repeat*

Pipelining: increased utilization

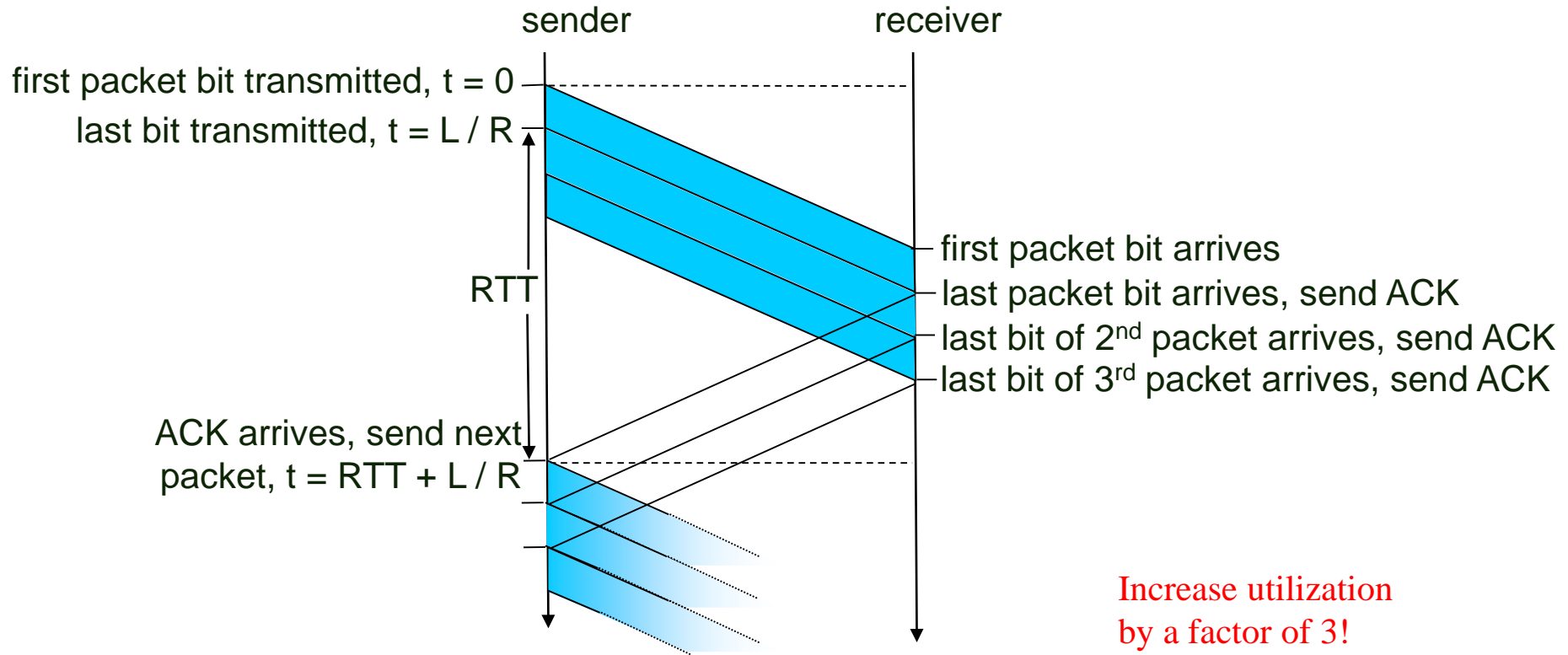

$$U_{\text{sender}} = \frac{3 * L / R}{RTT + L / R} = \frac{.024}{30.008} = 0.0008$$

Pipelining Protocols

Go-back-N: big picture:

- Sender can have up to N unacked packets in pipeline
- Rcvr only sends cumulative acks
 - Doesn't ack packet if there's a gap
- Sender has timer for oldest unacked packet
 - If timer expires, retransmit all unacked packets

Selective Repeat: big pic

- Sender can have up to N unacked packets in pipeline
- Rcvr acks individual packets
- Sender maintains timer for each unacked packet
 - When timer expires, retransmit only unack packet

Go-Back-N (GBN) Demonstration

- Protocol Demo
 - <https://www.youtube.com/watch?v=9BuaeEjleQI>
- http://media.pearsoncmg.com/aw/aw_kurose_network_4/applets/go-back-n/index.html
- A good video for Go-back-N
 - <https://www.youtube.com/watch?v=ZLtkhsgQp8U>

Transport Layer I: Summary

- principles behind transport layer services:
 - multiplexing, demultiplexing
 - reliable data transfer

Next:

- flow control
- congestion control
- instantiation and implementation in the Internet
 - UDP
 - TCP

Thank you

Any questions?